

FUNDERING OP PALEN - FUNDEX combipalen (volgens NEN 9997-1)

Paalrenvooi FUNDEX combinatie paal - fase 1a							
paalcode	trekpaal	paalpuntniveau	paalpuntniveau	afstandniveau	afstandniveau	paal lengte	Aantal
		L.o.v. NAP	L.o.v. NAP	L.o.v. NAP	L.o.v. NAP		
FP1	e540 670mm	26,00 m	-3,010 m	4,960 m	21,990 m		1
FP2	e540 670mm	24,00 m	-3,930 m	-5,880 m	20,070 m		44
FP3	e540 670mm	24,00 m	-3,630 m	-5,580 m	20,370 m		6
FP4	e540 670mm	24,00 m	-3,530 m	-5,480 m	20,470 m		15
FP5	e540 670mm	24,00 m	-3,430 m	-5,380 m	20,570 m		27
FP6	e540 670mm	24,00 m	-3,230 m	-5,180 m	20,770 m		4
FP7	e540 670mm	24,00 m	-3,130 m	-5,080 m	20,870 m		38
FP8	e540 670mm	24,00 m	-3,030 m	-4,980 m	20,960 m		3
FP9	e540 670mm	24,00 m	-2,930 m	-4,880 m	21,070 m		85
FP10	e540 670mm	24,00 m	-2,730 m	-4,680 m	21,270 m		15
FP11	e540 670mm	24,00 m	-2,280 m	-4,230 m	21,720 m		1
FP12	e540 670mm	24,00 m	-3,330 m	-3,280 m	23,670 m		6
FP13	e540 670mm	24,00 m	-0,150 m	-2,100 m	23,850 m		17
FP14	e540 670mm	24,00 m	-0,000 m	-1,960 m	24,000 m		1
FP15	e540 670mm	23,00 m	-0,170 m	-2,120 m	22,830 m		3
FP16	e540 670mm	23,00 m	-0,290 m	-1,720 m	23,260 m		4
FP17	e540 670mm	23,00 m	-0,260 m	-1,700 m	23,260 m		2
FP18	e540 670mm	23,00 m	-0,310 m	-1,640 m	23,210 m		2
FP19	e540 670mm	23,00 m	-0,300 m	-1,830 m	23,200 m		2
FP20	e540 670mm	23,00 m	-0,730 m	-1,220 m	23,730 m		9
FP21	e540 670mm	22,50 m	-3,930 m	-5,880 m	18,570 m		6
FP22	e540 670mm	22,50 m	-3,630 m	-5,580 m	18,870 m		12
FP23	e540 670mm	22,50 m	-3,530 m	-5,480 m	18,970 m		18
FP24	e540 670mm	22,50 m	-3,230 m	-5,180 m	19,270 m		65
FP25	e540 670mm	22,50 m	-3,130 m	-5,080 m	19,370 m		10
FP26	e540 670mm	22,50 m	-3,030 m	-4,980 m	19,460 m		28
FP27	e540 670mm	22,50 m	-2,930 m	-4,880 m	19,570 m		28
FP28	e540 670mm	22,50 m	-2,730 m	-4,680 m	19,770 m		82
FP29	e540 670mm	22,50 m	-2,280 m	-4,230 m	20,220 m		3

- LUITGANGSPUNTEN**
- Paal 1, 1,5m + NAP
 - Hoogte grondwaterstand is 0,1 m + NAP. Dit dient door derden bevestigd te worden voor de definitieve uitwerking.
 - Boringen aan verankerd wanden nadat kettingen van de betreffende fase gesloten is (indien van toepassing).
 - Bouwkuip wordt gerealiseerd met stalen damwanden welke buiten bouwkuip deels verankerd en deels voorzien van een steunborm worden d.m.v. grondsluis.
 - Inhoud grondslag met verankering op palen en beledingen n.b. door derden:
 - Bevestigen conform opgave Crux d.d. 15-02-2023. Lasten afhankelijk van duur uitvoering en volgende en zijn door Crux bepaald op basis van de volgende uitgangspunten conform opgave KWA:
 - Start ontgraven tot onder start installeren paal 5 weken.
 - Start ontgraven tot onder start installeren fase 1, 305 weken.
 - Voor algemene richtlijnen uitvoering palen, paaldragers, locaties sonderingen, etc. zie DO funderingsplan C033 engineering 01 met kenmerk RA221224 d.d. 24-05-2022.
 - Fundex combipalen (2540/520 mm) (of gelijkwaardig).
 - Paalwrijving volgens opgave leverancier ter controle aan Aveco de Bondt (De berekening op een eccentriciteit van 0,1h ± 50mm):
 - Maximale trek 2800 kN.
 - Maximale trek 640 kN.
 - Normaalkracht 63 kN (inclusief).
 - Paalwrijvingen doorgeven aan Aveco de Bondt middels tekeningen.
 - Milieuclassificatie C35/45 (indien chemische aanstrijk (SA2) van toepassing is dan dient dit door derden aangegeven te worden).
 - T.b.v. de uitvoering van de palen wordt de grond niet voorgevoerd.
 - Ten behoeve van het definitieve plan dient nog aanvullende sonderingen uitgevoerd te worden na sloop van de opstallen.
 - Dit heeft mogelijk consequenties voor het palenplan.
 - De inhoud van funderingsplan op het funderingsplan is nog niet in kaart gebracht. In vervolgplan kan dit wellicht op basis van archeologisch onderzoek mogelijk inzichtelijk gemaakt worden.
 - Voor de definitieve uitvoering zijn inrichtingen in sloop noodzakelijk. Dit heeft mogelijk gevolgen voor het funderingsontwerp.
 - Rondom ketting grondwaterboring toepassen met ultra prof aandring, conform Geohydrologisch onderzoek door Aveco de Bondt d.d. 04-03-2021.

Deze tekening is gebaseerd op:
 Model Aveco de Bondt: MWV_K_CON_A05_R21214570
 Constructieve uitgangspunten Aveco de Bondt: 214570_A05_RAP_R13_0001
 Onderlegger derden: MWV_K_BWK_R18_R21

A.O. 15-12-2023: heroverlegging ketting ketting aan aanpassing naar openbaar
 I.O. 15-03-2023: toevoeging van palen & diverse aanvullingen
 D.O. 22-12-2022: eerste uitgave; def.
 L.O. 12-03-2022: Datum: Dinsdag 12 maart 2022

Project: Marktkwartier West te Amsterdam
 Onderdeel: Paalrenvooi Fase 1a
 Architect: HBB
 Aanvrager: Koning Willem-Alexander
 Opdrachtgever: Marktkwartier CV

Definitief ontwerp
 Schaal: As indicated
 Formaat: A0+ (841x1189)
 Tekeningnummer: 214570
 MWV_CON_K_1a_00-000

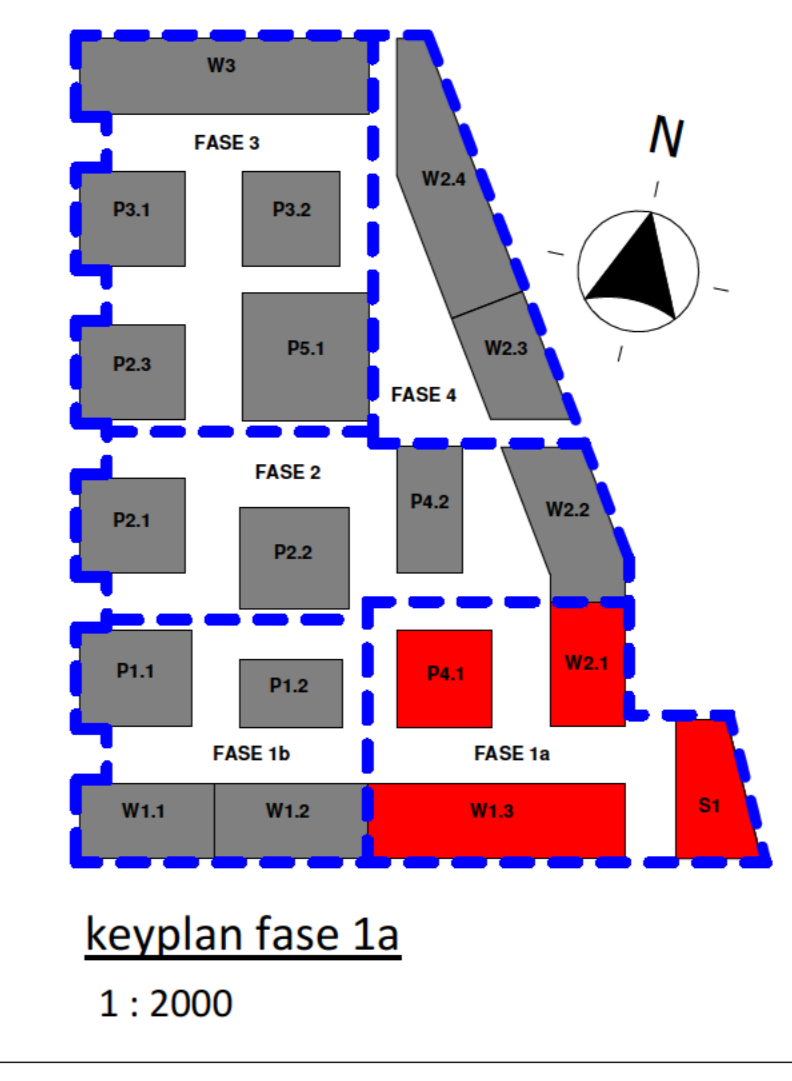

keyplan fase 1a
1: 2000



damwand met steunbinnenzijde

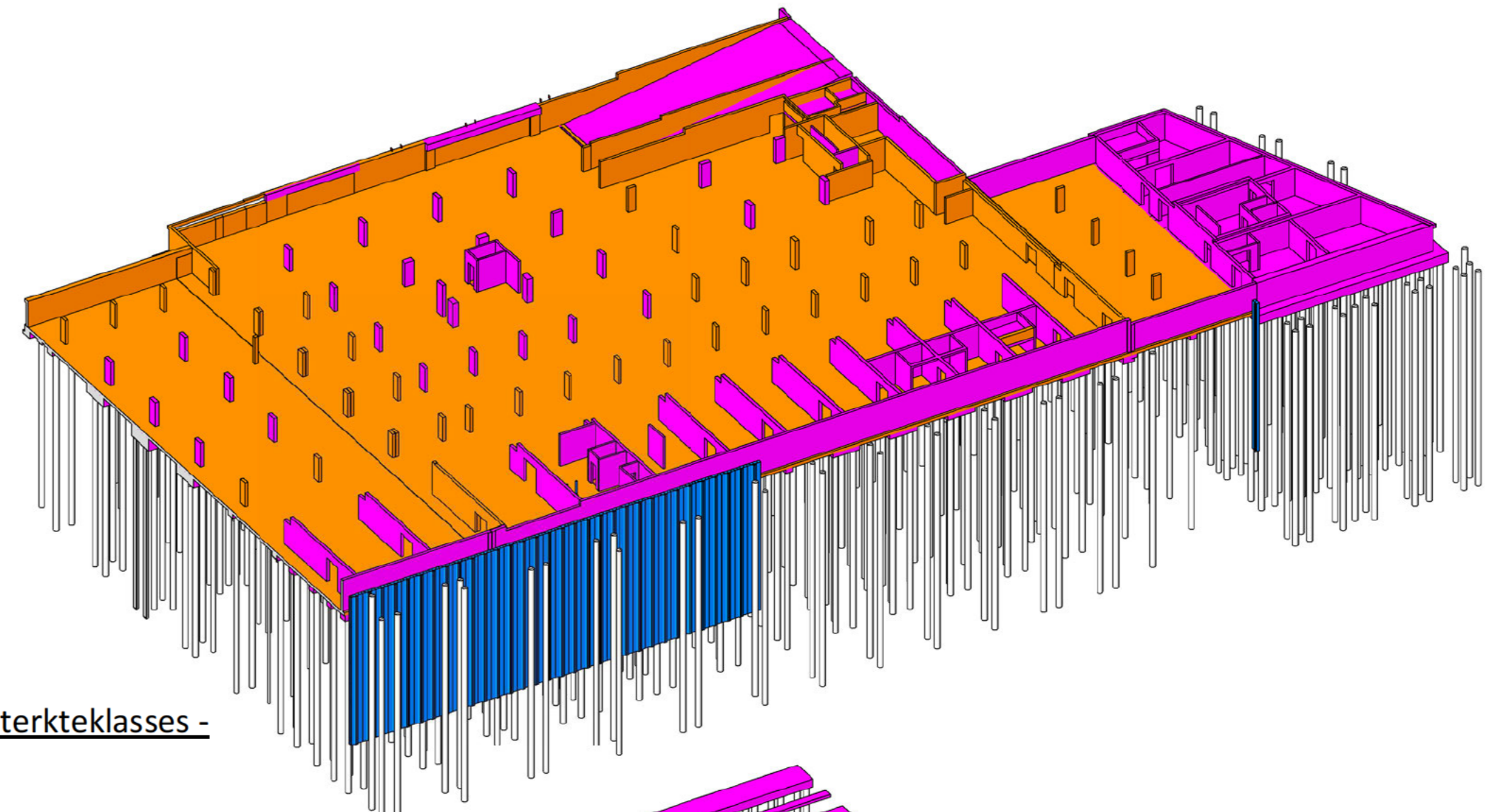

3D isometrie betonsterkteklassen - keldervloer

BETON STERKTEKLASSE	
	C30/37
	C35/45
	C45/55

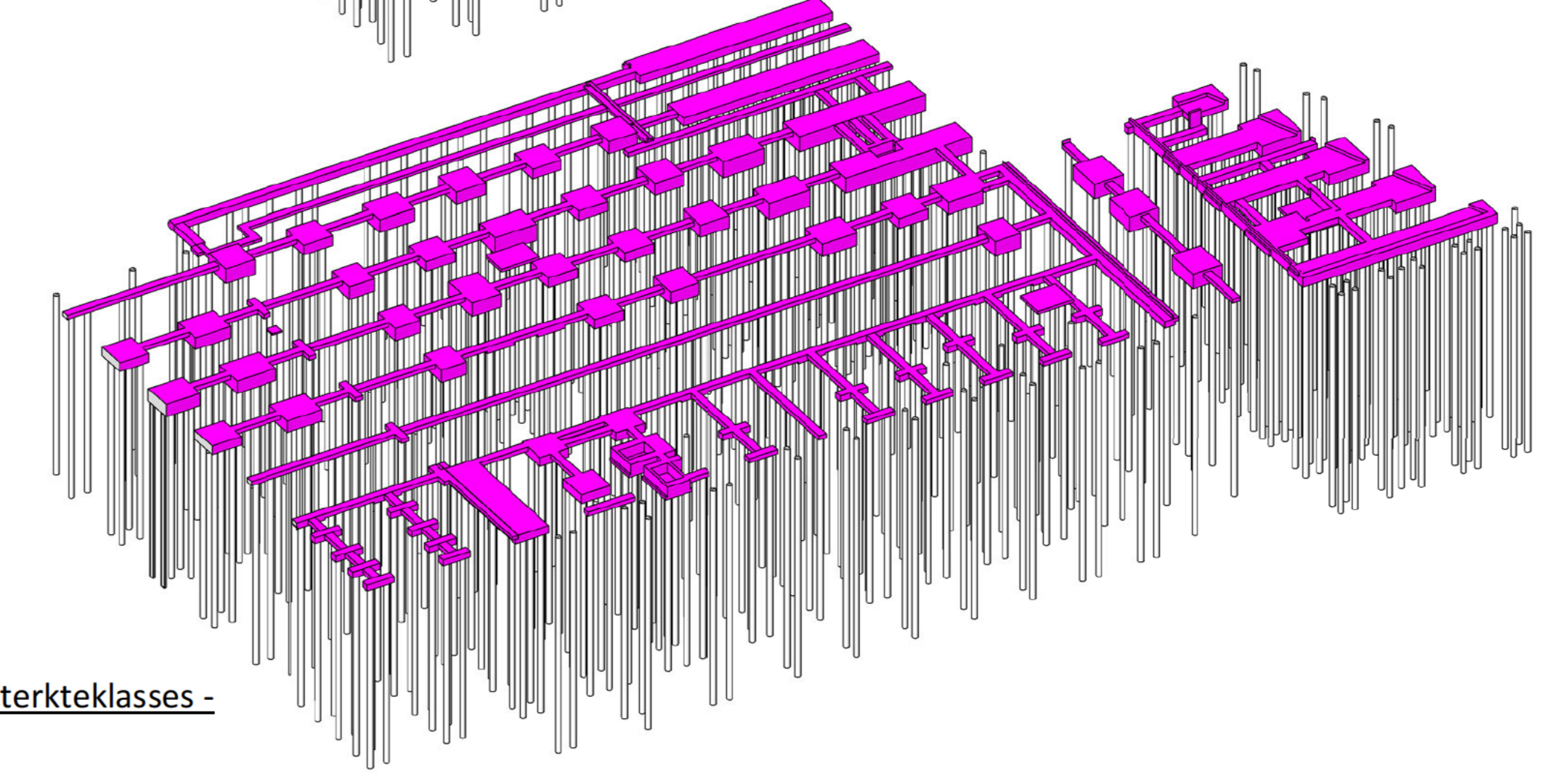

3D isometrie betonsterkteklassen - fundatie

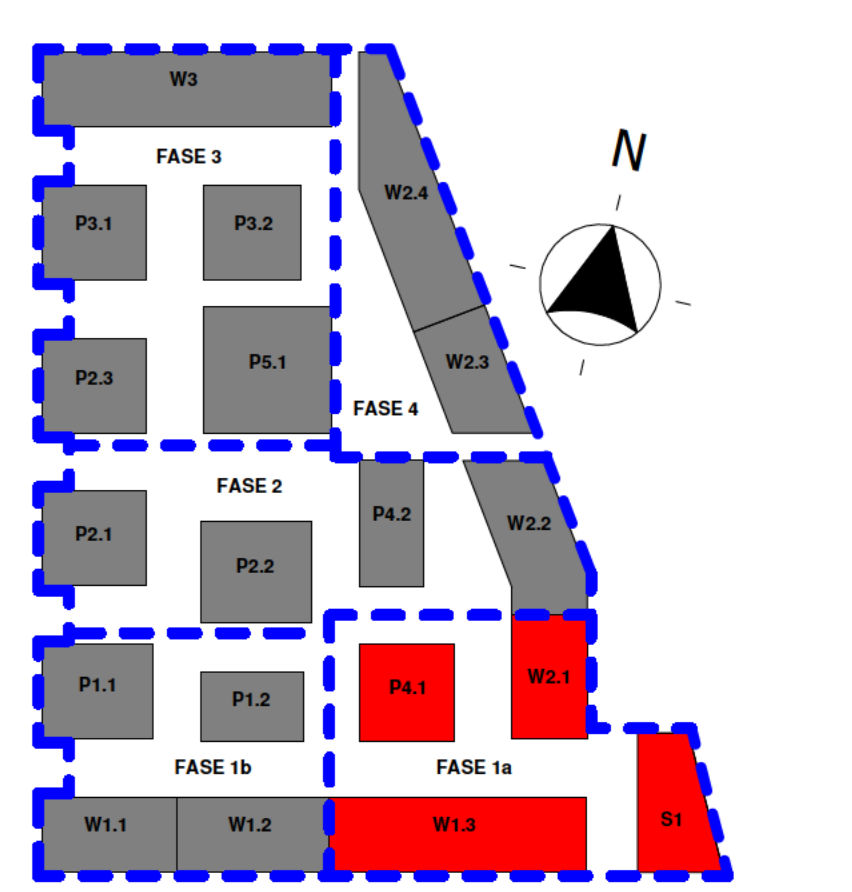

keyplan fase 1a
1:2000

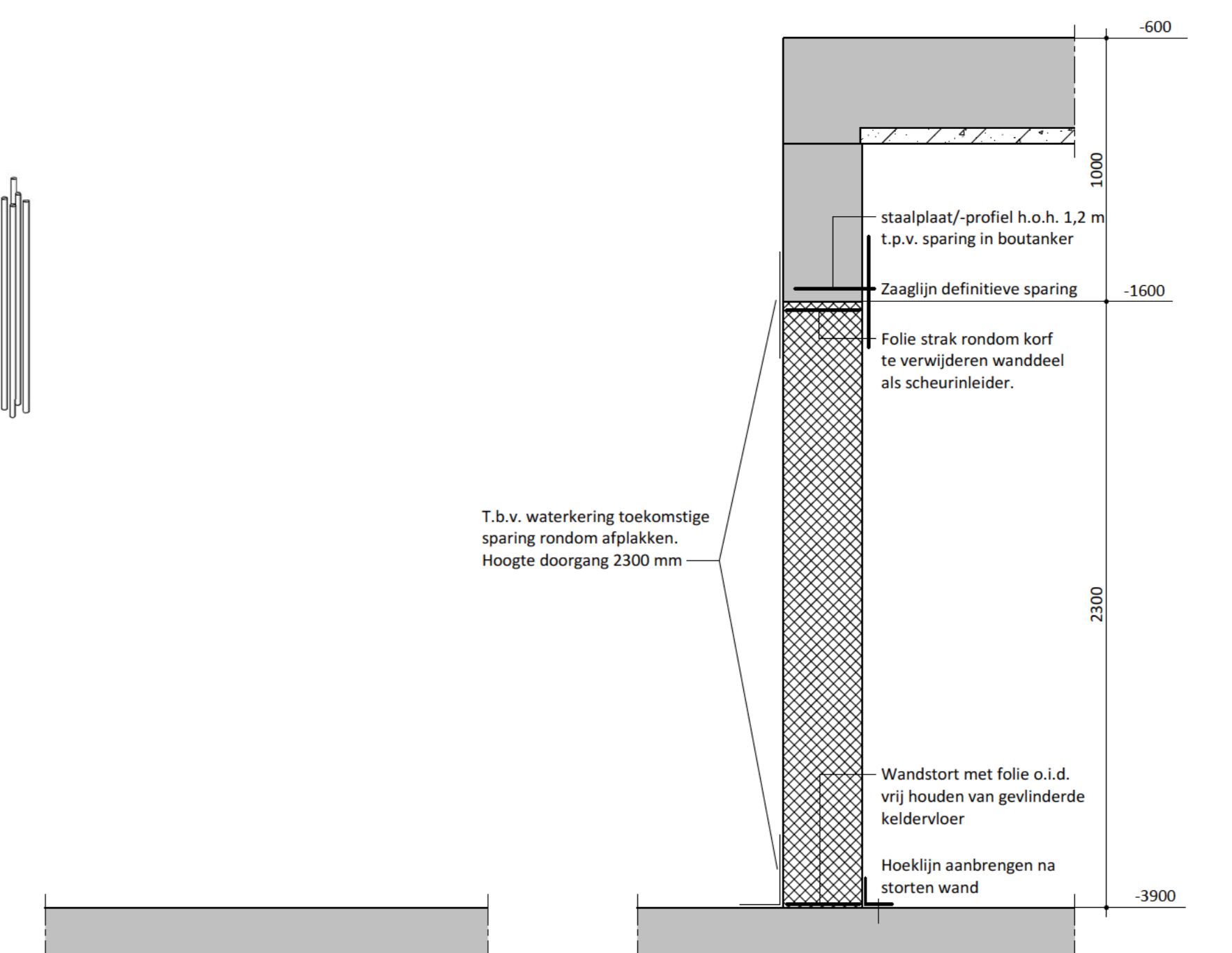

principe later te verwijderen kelderwand
1:20

principe leidingen onder keldervloer
1:20

verankerde damwand

verankerde damwand

verankerde damwand

UITGANGSPROTOCOL

- Dilatatievoegbanden en deuren volgens aanneem in overleg met leverancier. Dit om risico schade/lekages te beheersen.
- Rondom kelder grondverbetering toepassen met uiterst grof zand/grind, eea conform Geotechnologisch onderzoek door Aveco de Bondt i.d. 04-03-2021

ALGEMENE OPMERKINGEN

- Alle maatvoering in mm en in het werk te controleren, tenzij anders aangegeven
- Voor belastingen op kelderdek zie rapport 214570_AdB_RAP_K13-0001
- steel sterkteklasse S355, tenzij anders vermeld
- kalkzandsteen sterkteklasse C52, tenzij anders vermeld
- hout sterkteklasse C24, tenzij anders vermeld
- beton sterkteklasse C30/37, tenzij anders vermeld
- prefab beton sterkteklasse C45/55, tenzij anders vermeld
- brandwerendheids kooldagconstructie 120 minuten
- Alle spangzones zullen worden dichtgemaakt tussen de leidingen/doorvoeren waarbij zoveel mogelijk wapening kan doorlopen

AANDUIDINGEN

BK = beton kolom	KK = kolomprofiel koud getrokken
BB = beton balk	KW = kolomprofiel warm gewalst
PK = prefab beton kolom	B = busprofiel
PBB = prefab beton balk	BW = brandwerende a'wringing

LEGENDA

	beton op de vloer; in het werk gestort		overboordingrichting vloer
	beton op de vloer; prefab		→ kolom boven vloer
	metseelwerk op de vloer; kalkzandsteen		→ kolom onder vloer
	constructie onder de vloer		P = vloerplaat (mm)
			D = diameter (mm)

Deze tekening is gebaseerd op:
 Model Aveco de Bondt: MKW_K_CON_ADB_R21214570
 Constructieve uitgangspunten Aveco de Bondt: 214570_AdB_RAP_K13-0001
 Onderlegger: dorden: MKW_K_BWK_HFB_R21

Uitgave	Datum	Omschrijving
0.0	15-12-2021	toevoeging: wijzigging kelder / om aanpassing naar openbaar
1.0	15-03-2023	toevoeging: wijzigging gaten & diverse aanvullingen
1.02	02-02-2023	toevoeging: diverse aanvullingen
2.0	06-05-2023	eerste uitgave; def.
1.0	11-07-2022	eerste uitgave
		Datum
		Omschrijving

Project: Marktkwartier West te Amsterdam
 Onderdeel: Keldervloer Fase 1a
 Architect: HBB
 Aanneemer: Kelder Wicoudt Amsterdam
 Opdrachtgever: Marktkwartier CV

Projectleider:

Definitief ontwerp

Aveco de Bondt

214570 MKW_CON_K_1a_00-001

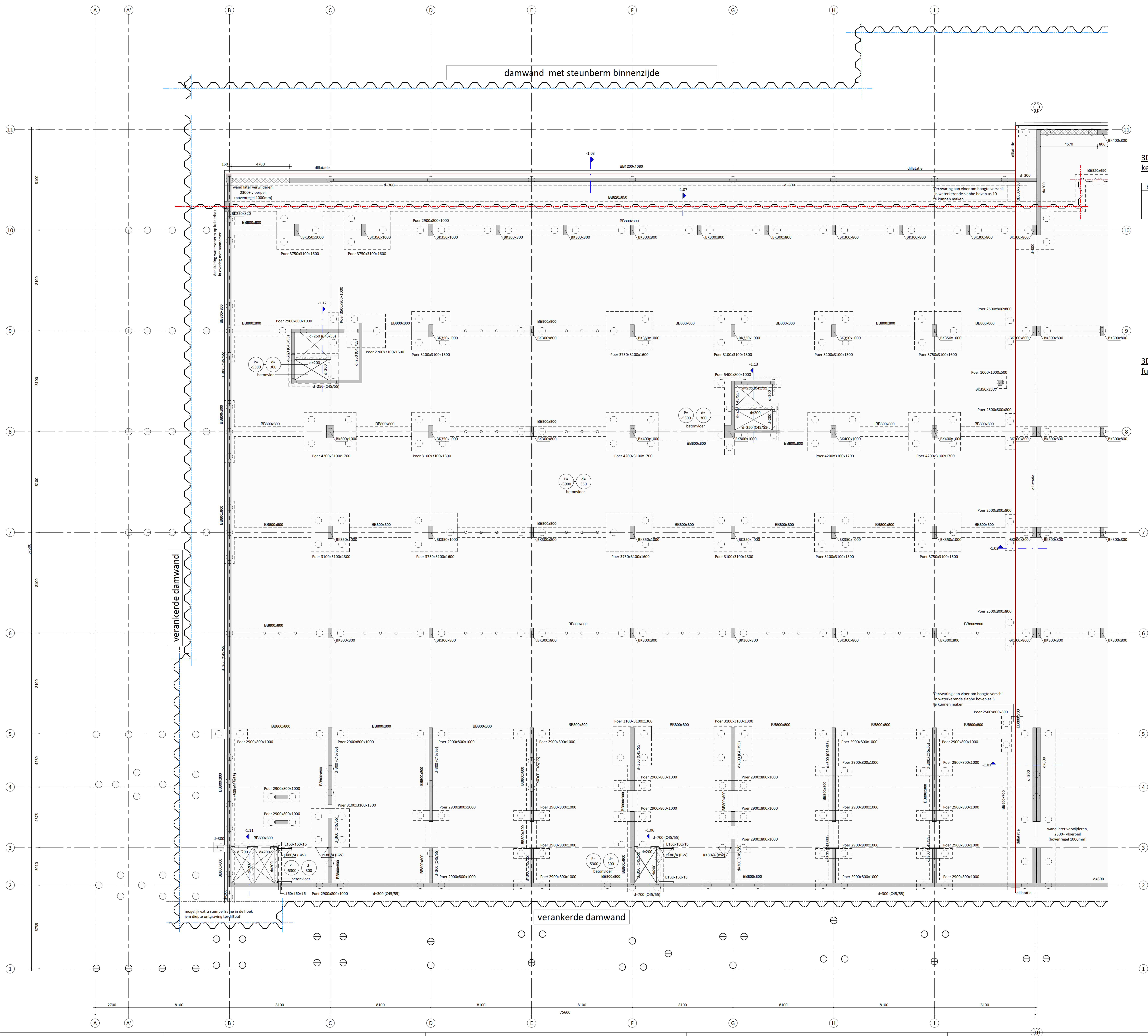

3D isometrie betonsterkteklassen - keldervloer

BETON STERKTEKLASSE	
	C30/37
	C35/45
	C45/55

3D isometrie betonsterkteklassen - fundatie

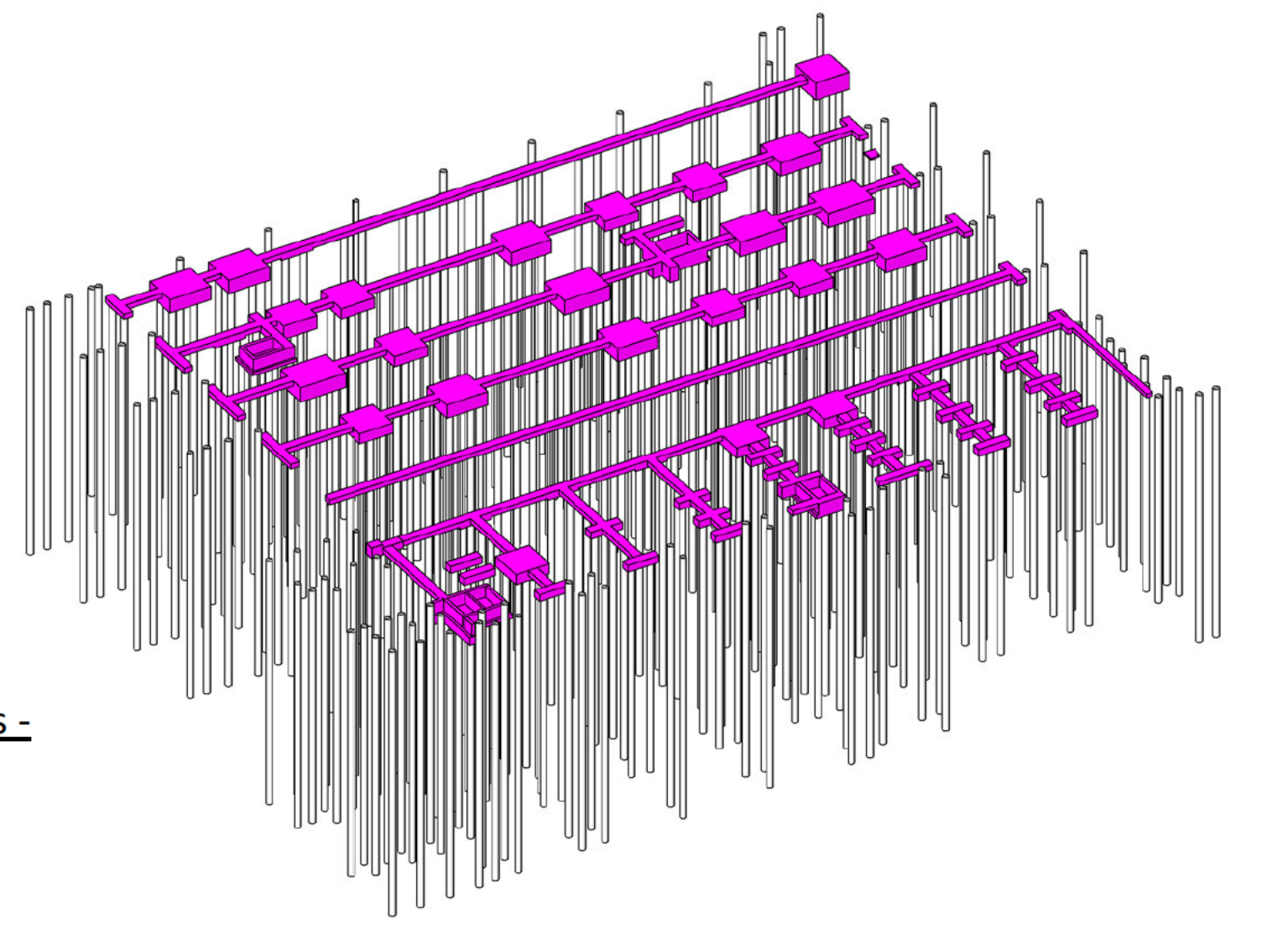
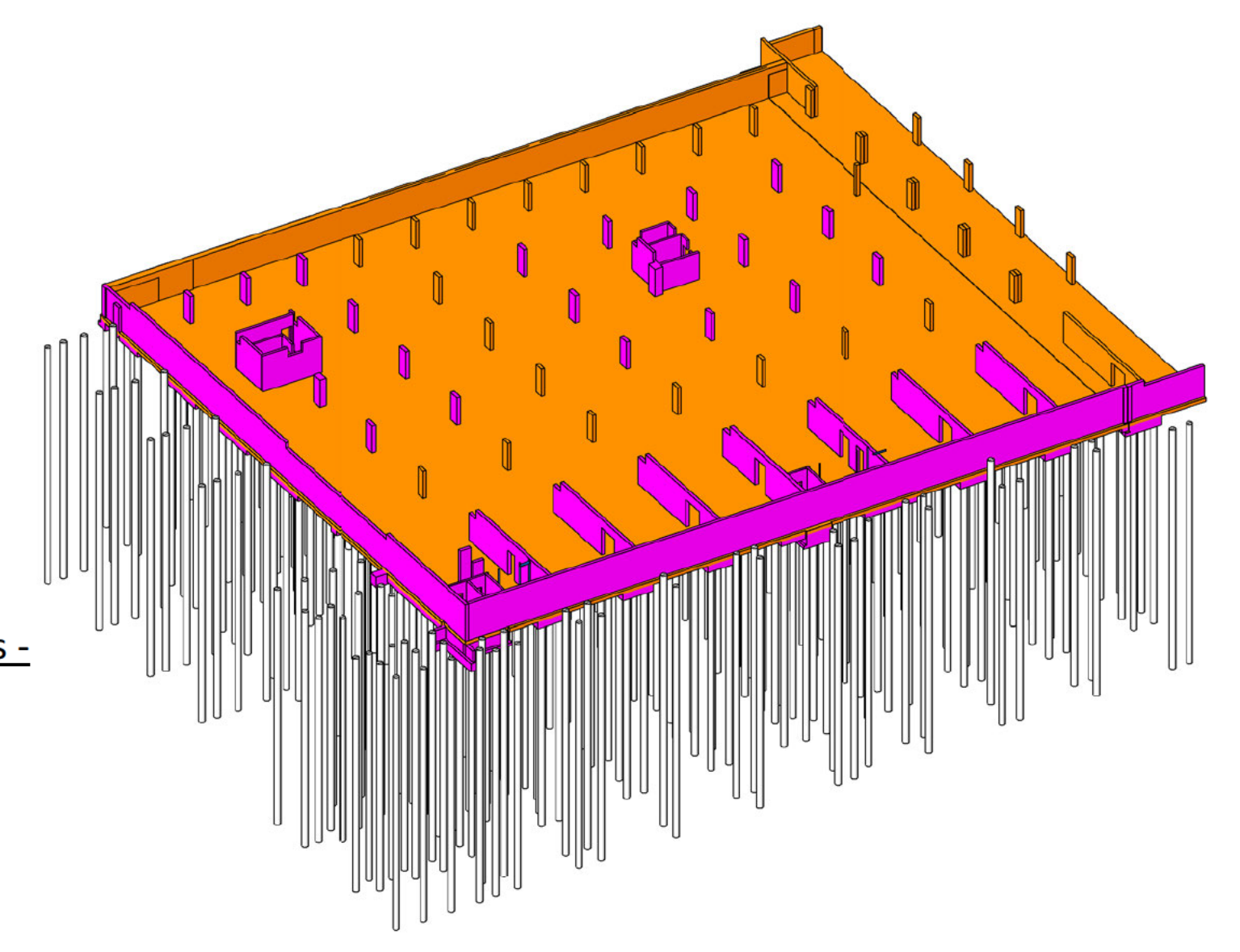

keyplan fase 1b
1 : 2000

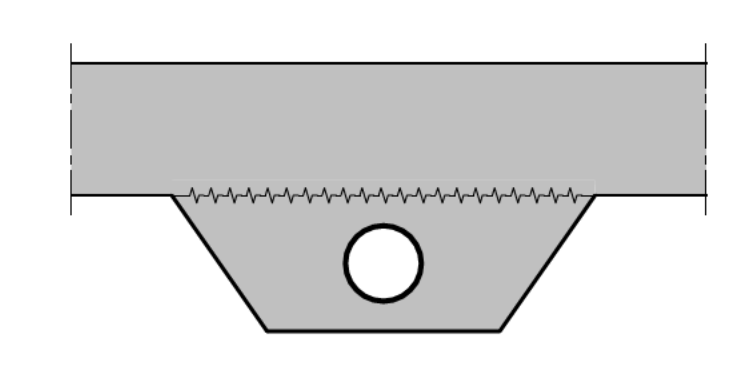
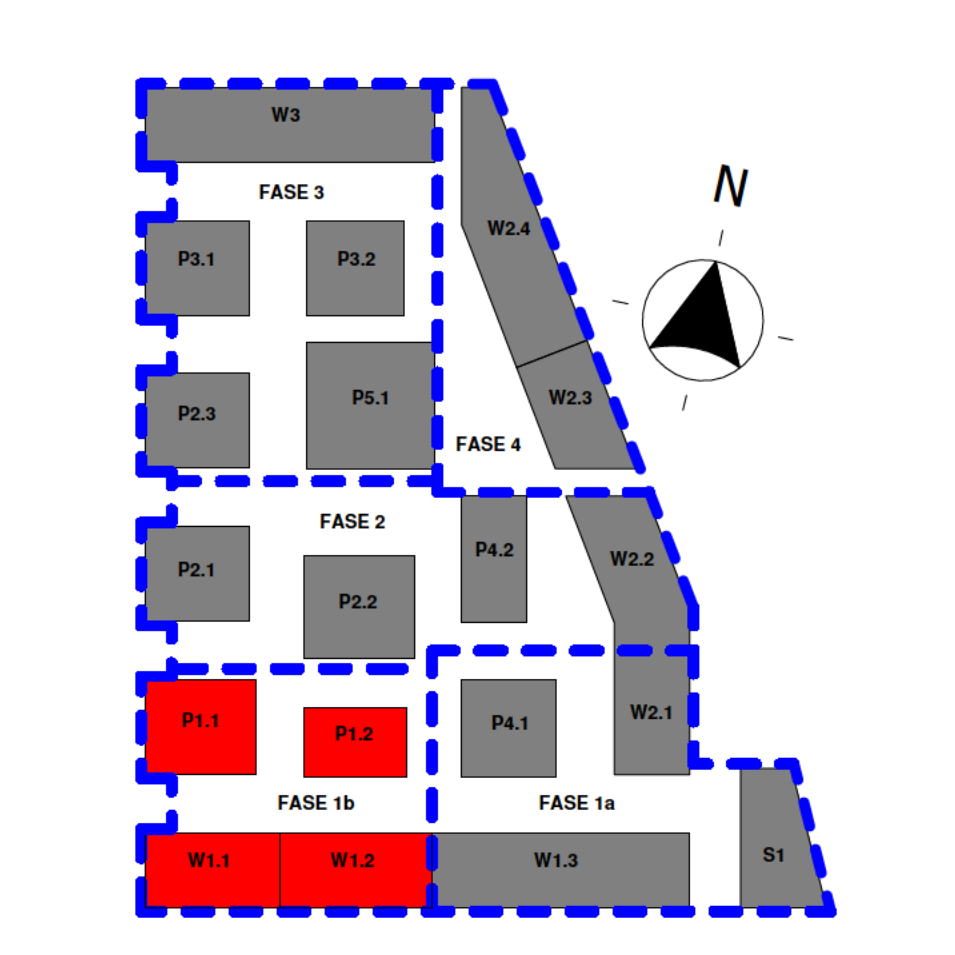

principe leidingen onder keldervloer
1 : 20

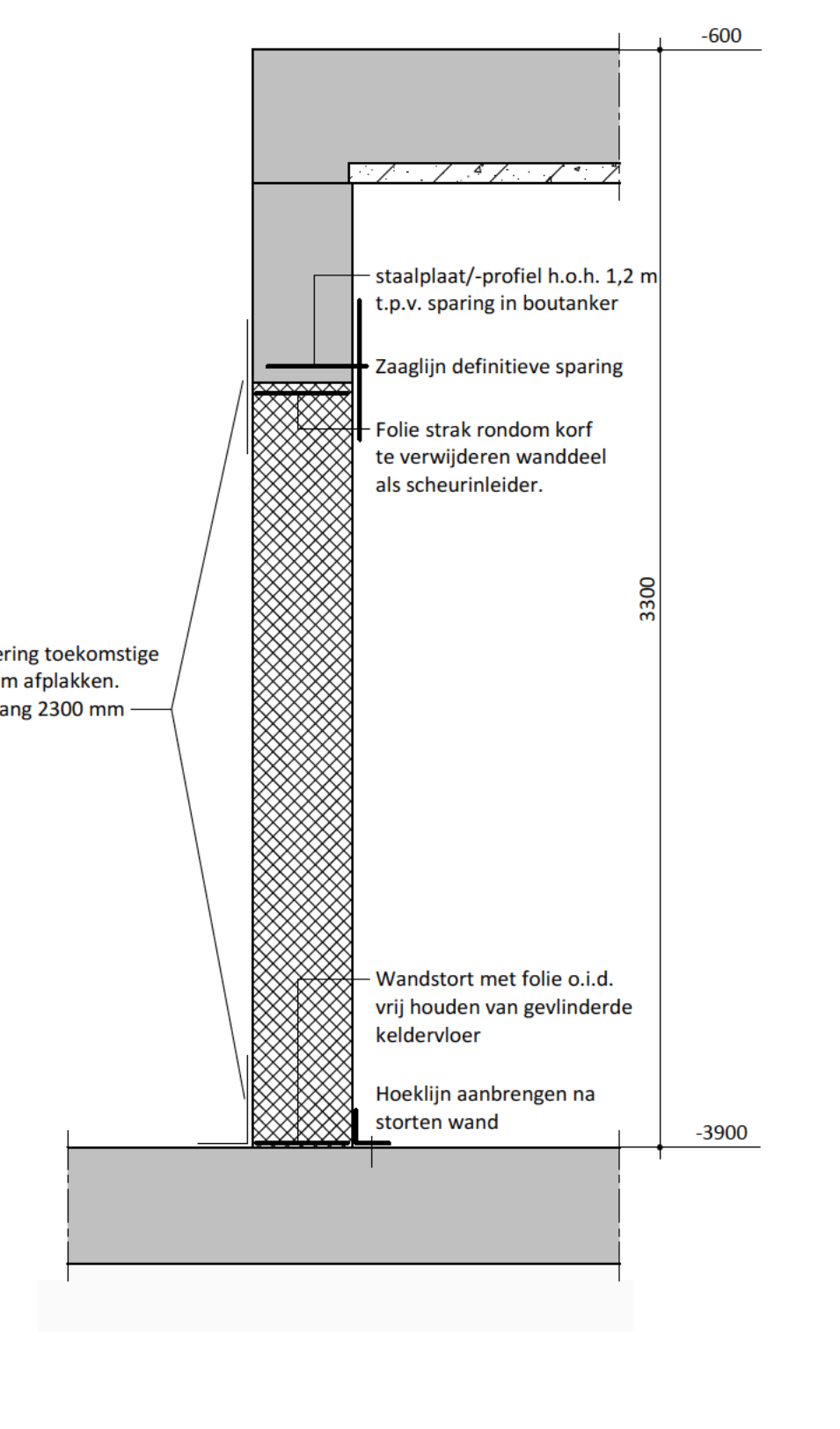

principe later te verwijderen kelderwand
1 : 20

UITGANGSPROTOCOL
 - Dilatatievoegbanden en deuken volgen aanmer in overleg met leveranciers. Dit om risico schade/flekages te beheersen.
 - Rondom kelder grondverbetering toepassen met uiterst grof zand/grind, eea conform Geohydrologisch onderzoek door Aveco de Bondt d.d. 04-03-2021

ALGEMENE OPMERKINGEN
 - alle maatvoering in mm en in het werk te controleren, tenzij anders aangegeven
 - Voor belastingen op kelderdek zie rapport 214570, afd. 1A.1, 11-10-2001
 - staal sterkteklasse S355, tenzij anders vermeld
 - kalkzandsteen sterkteklasse C12, tenzij anders vermeld
 - hout sterkteklasse C24, tenzij anders vermeld
 - beton sterkteklasse C30/37, tenzij anders vermeld
 - prefab beton sterkteklasse C45/55, tenzij anders vermeld
 - brandwerendheidswaarde hoofddragconstructie: 120 minuten
 - Alle springingen zullen worden dichtgestort tussen de ledingen/doorvoeren waarbij zoveel mogelijk wapening kan doorlopen

AANDUIJINGEN
 BK = beton kolom KK = kokkerprofiel koud getrokken
 BB = beton balk KW = kokkerprofiel warm gewalst
 PKB = prefab beton kolom B = buisprofiel
 PFB = prefab beton balk BW = brandwerende afwerking

LEGENDA
 [Symbol] beton op de vloer; in het werk gestort [Symbol] overspanningsrichting vloer
 [Symbol] beton op de vloer; prefab [Symbol] kolom boven vloer
 [Symbol] metselwerk op de vloer; kalkzandsteen [Symbol] kolom onder vloer
 [Symbol] constructie onder de vloer [Symbol] vloerpeil (mm)
 [Symbol] [Symbol] dilatatievloer (mm)

Deze tekening is gebaseerd op:
 [Symbol] [Symbol] [Symbol]

10-11-2023	toevoeging; wijzigingen kelder ijm aanpassing naar openbaar
20-06-2023	eerste uitgaver, def.
10-06-2023	[Symbol]
Totaal: [Symbol] [Symbol]	
Project:	Marktkwartier West te Amsterdam
Onderdeel:	Keldervloer Fase 1b
Architect:	HFH
Aannemer:	Kondor Wessels Amsterdam
Opdrachtgever:	Marktkwartier CV

onderzoekt ontwerp adviseert

Definitief ontwerp

Definitief

Schaal: As indicated

Projectnummer: [Symbol]

Format: A4 (841x1199)

Tekeningnummer: [Symbol]

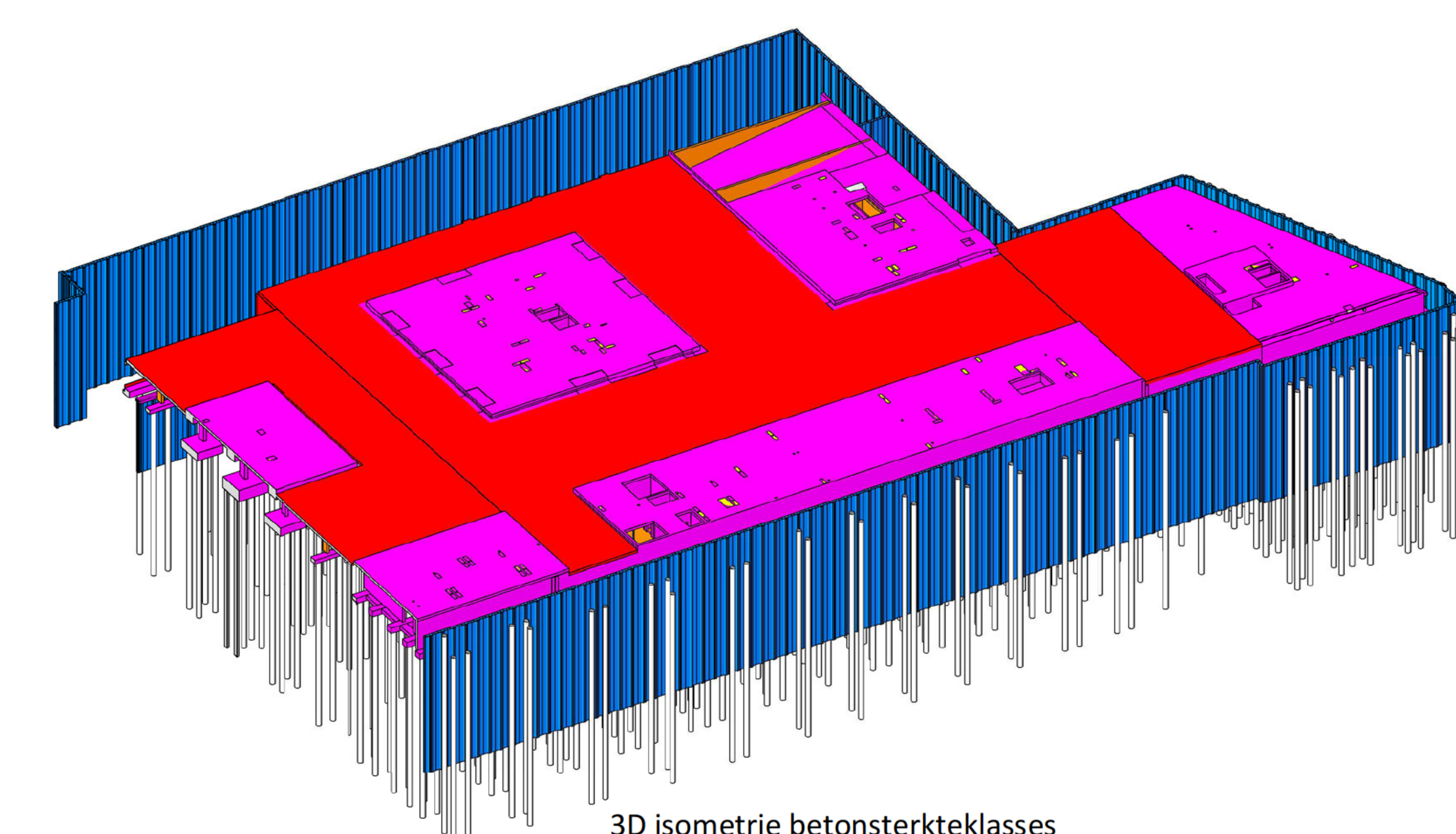
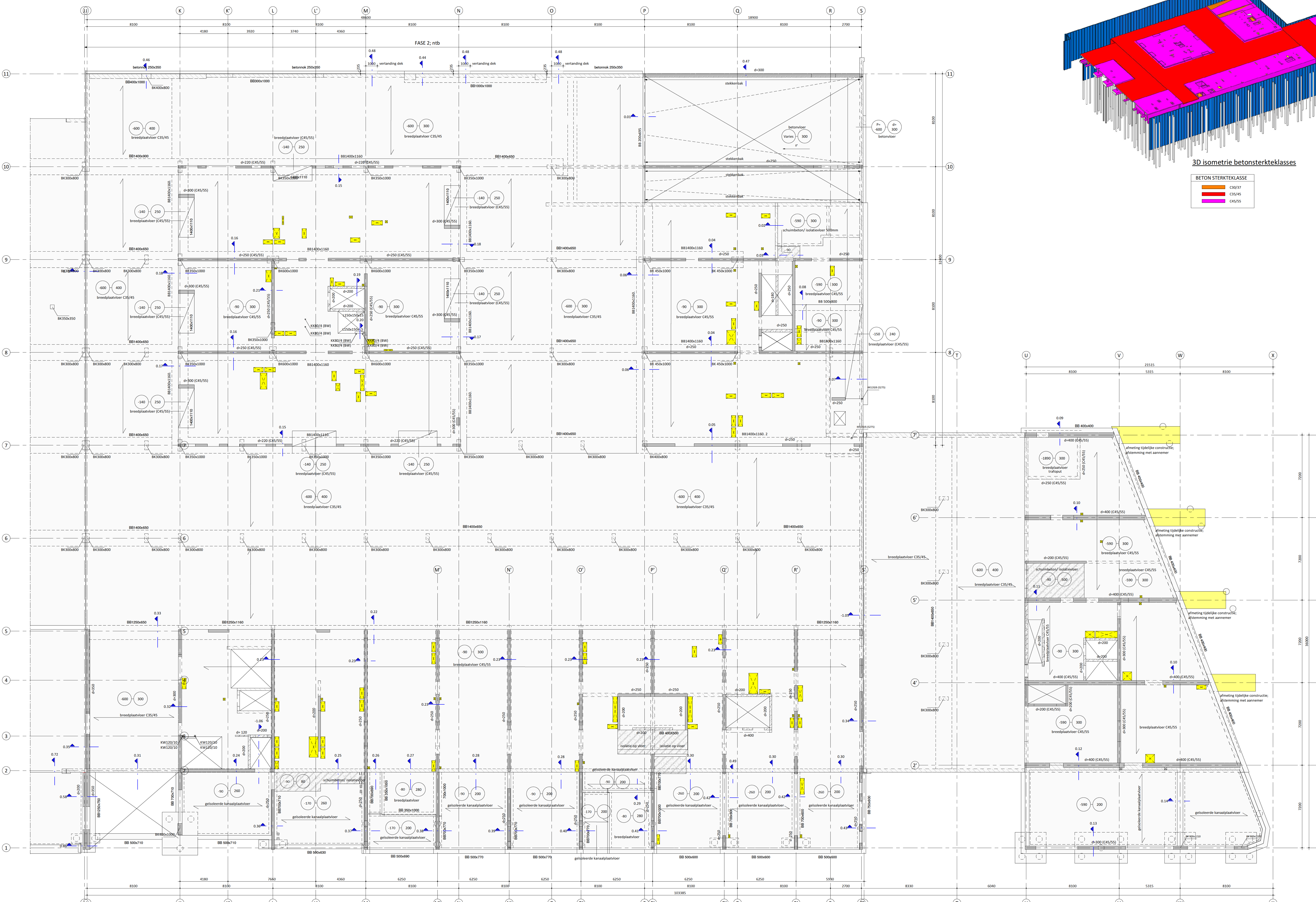

3D isometrie betonsterkteklassen

BETON STERKTEKLASSE	
	C30/37
	C35/45
	C45/55

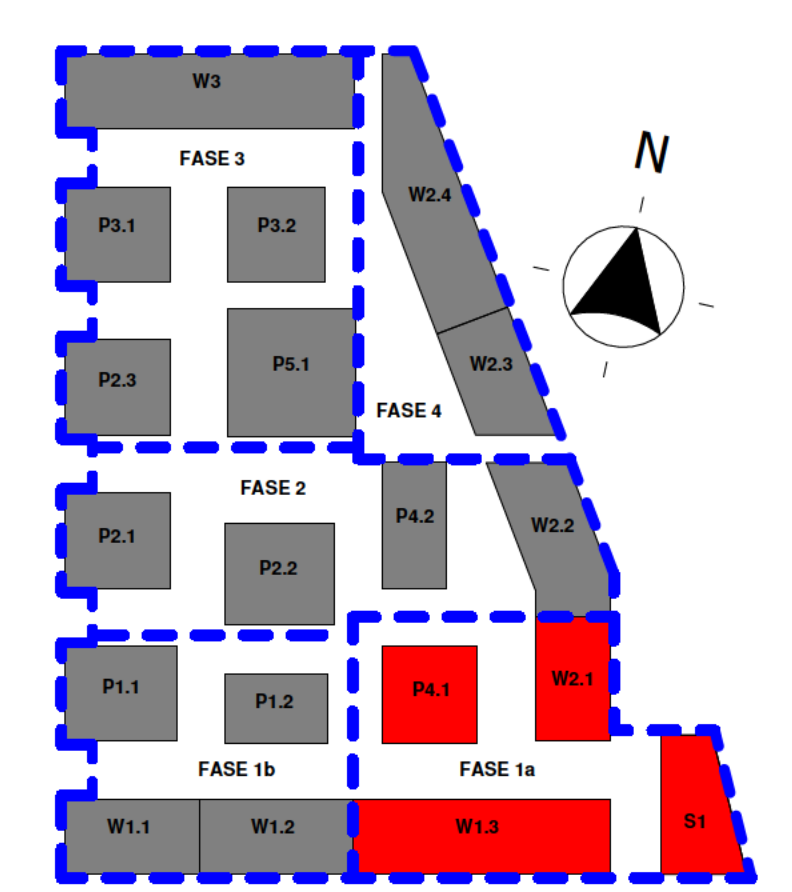

keyplan fase 1a
1:2000

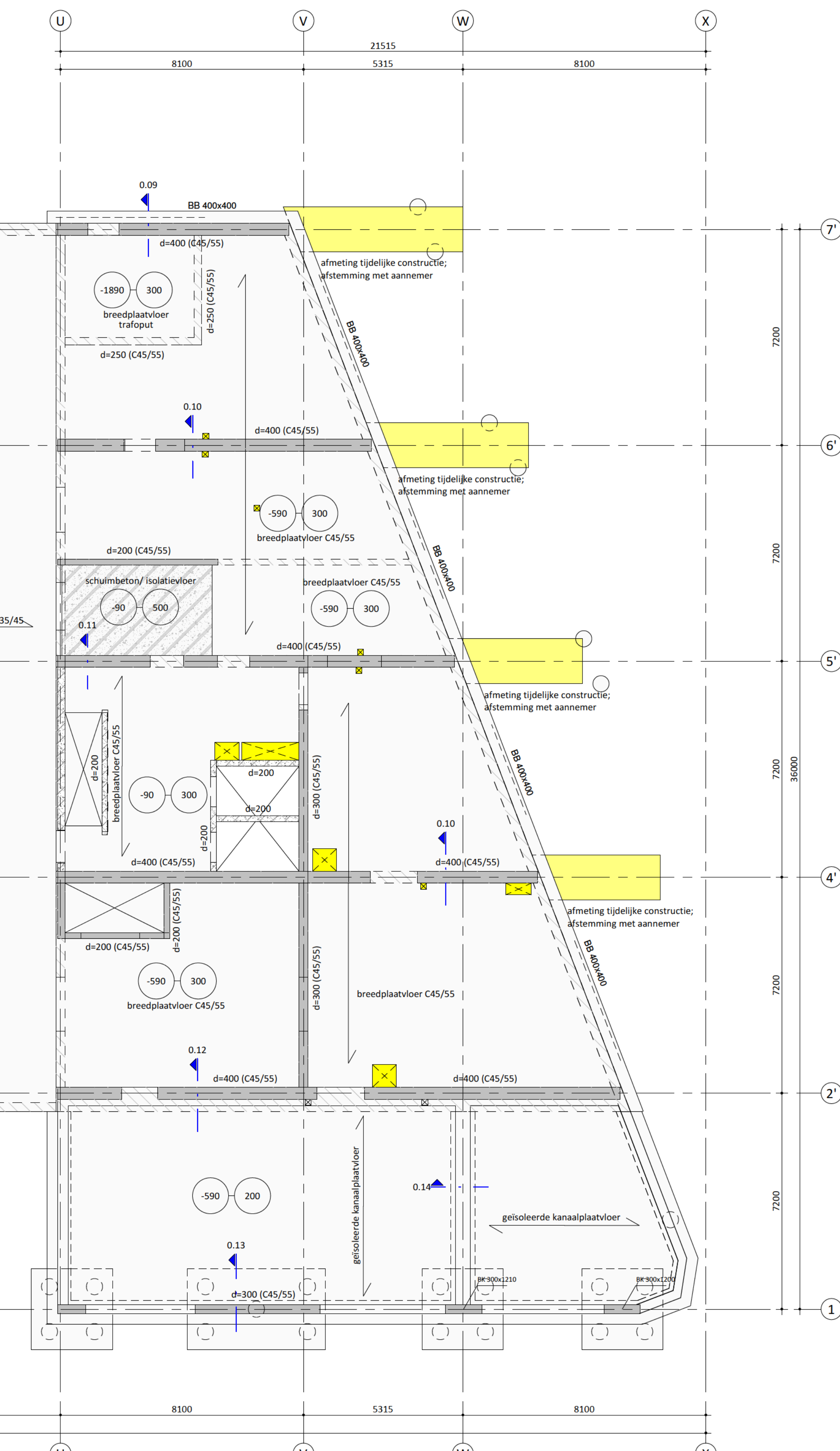

UITGANGSPUNTEN

- Peil is 1,25m + NAP conform opgave HFB.
- Hoogte grondwatersstand is 0,1 m +NAP. Dit dient door derden bevestigd te worden voor de definitieve uitwerking.
- Bemaling kan verwijderd worden nadat kelderdek van de betreffende fase gerealiseerd is (text: afwerking).

ALGEMENE OPMERKINGEN

- alle maatvoering in mm en in het werk te controleren, tenzij anders aangegeven
- Voor belastingen op kelderdek zie rapport 214570_AdB_RAP_K1a-0001
- staal sterkteklasse S355, tenzij anders vermeld
- kalkzandsteen sterkteklasse C32, tenzij anders vermeld
- hout sterkteklasse C24, tenzij anders vermeld
- beton sterkteklasse C30/37, tenzij anders vermeld
- prefab beton sterkteklasse C45/55, tenzij anders vermeld
- brandwerendheidsklasse hoofddragconstructie: 120 minuten
- alle springproeven zullen worden dichtgesteld tussen de ledingen/voorveren waarbij zoveel mogelijk wapening kan doorlopen

AANDUIJINGEN

- BB = beton kolom
- BK = beton balk
- PKB = prefab beton kolom
- PBB = prefab beton balk
- KK = kolkerprofiel koel getrokken
- KW = kolkerprofiel warm gewalst
- B = buisprofiel
- BW = brandwerende afwerking

LEGENDA

- beton op de vloer; in het werk gestort
- beton op de vloer; prefab
- metselewerk op de vloer; kalkzandsteen
- constructie onder de vloer
- overspanningsrichting vloer
- kolom boven vloer
- kolom onder vloer
- vloerpeil (mm)
- dikte vloer (mm)

Deze tekening is gebaseerd op:
 Model Aveco de Bondt: MKW_K_CON_A0B_R21314570
 Constructieve uitgangspunten Aveco de Bondt: 214570_AdB_RAP_K1a-0001
 Onderlegger derden: MKW_K_BWK_HFB_R21

6/0	15-12-2023	toevoeging; wijzigingen kelder 1m aanpassing naar openbaar
5/0	21-11-2022	eerste uitgaveset
4/0	19-07-2022	toevoeging; blok 51 aanpassing
3/0	15-07-2022	toevoeging; blok W.3
2/0	25-05-2022	toevoeging; blok P4.1
1/0	11-05-2022	eerste uitgave

Project: Marktkwartier West te Amsterdam
 Onderdeel: Begane grondvloer fase 1a
 Architect: HFB
 Aannemer: Konoord Wessels Amsterdam
 Opdrachtgever: Marktkwartier CV

Projectleider:
Aveco de Bondt
 Definitief ontwerp adviseur

Definitief ontwerp
 Definitief
 Formaat: A4 (841x399)
 Projectnummer: 214570
 MKW_CON_K_1a_D0-100

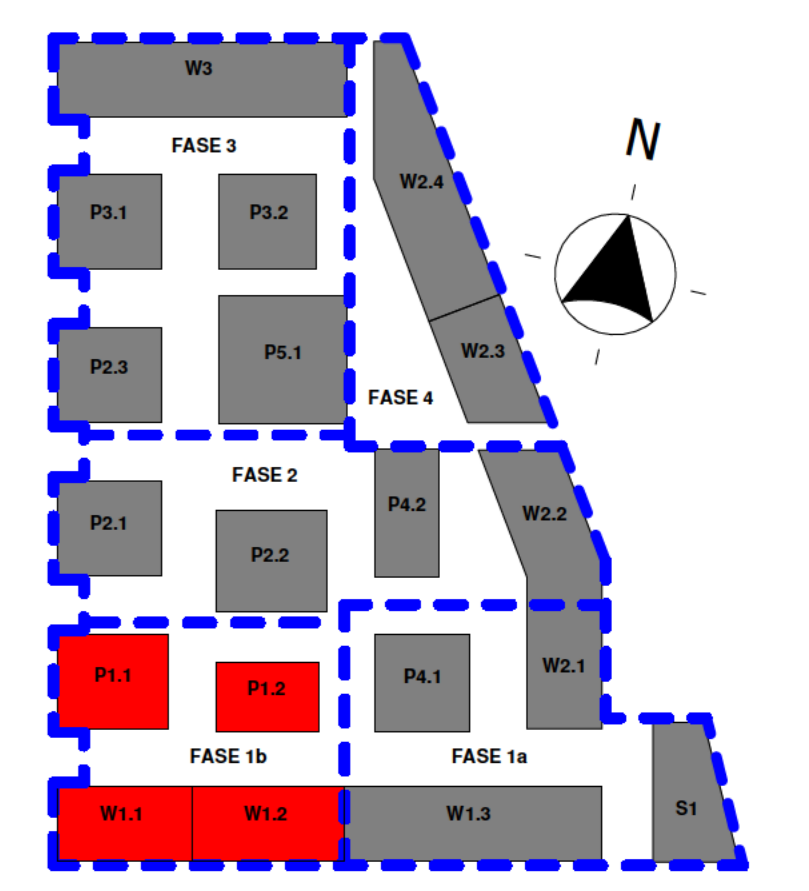

keyplan fase 1b
1 : 2000

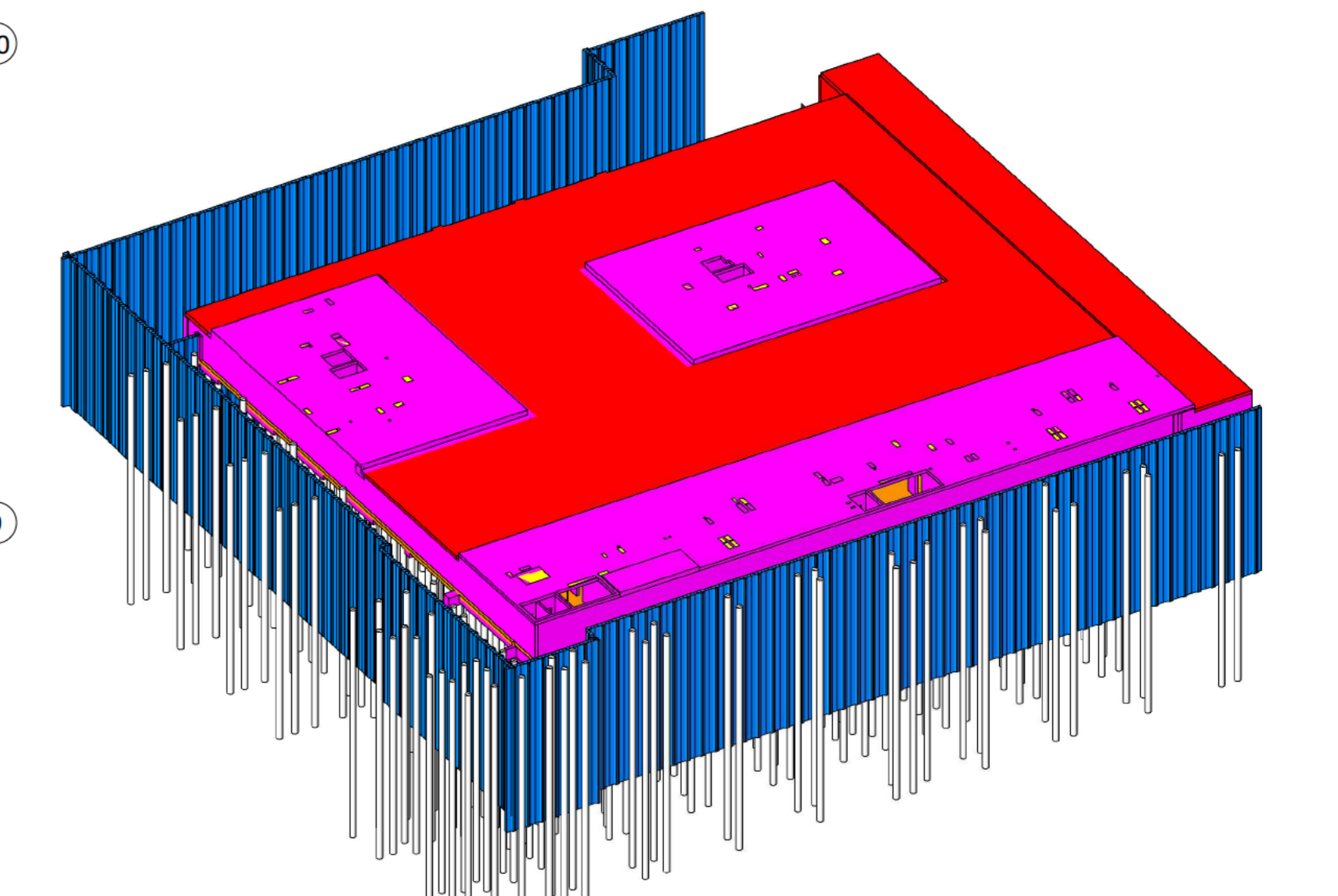

3D isometrie betonsterkteklassen

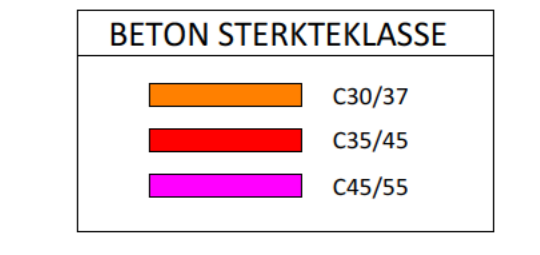

UITGANGSPUNTEN

- Peil is 1,95m + NAP conform opgave HFB;
- Hoogte grondwaterstand is 0,1 m +NAP. Dit dient door derden bevestigd te worden voor de definitieve uitwerking;
- Bemaling kan verwijst worden naar kaderde van de betreffende fase gerealiseerd is (incl. afwerking);
- Invloed balktijfheid dek in rekening gebracht te worden door leverancier.
- Hiervoor kan CUR-aanbeveling 099 aangehouden worden.

ALGEMENE OPMERKINGEN

- alle maatvoering in mm en in het werk te controleren, tenzij anders aangegeven
- Voor belastingen op kelderdek zie rapport 214570_Adb_RAP_K1D-0001
- staal sterkteklasse S355; tenzij anders vermeld
- kalkzandsteen sterkteklasse CS12; tenzij anders vermeld
- hout sterkteklasse C24; tenzij anders vermeld
- beton sterkteklasse C30/37; tenzij anders vermeld
- prefab beton sterkteklasse C45/55; tenzij anders vermeld
- brandwerendheids hoofddraagconstructie; 120 minuten
- Alle springzones zullen worden dichtgemaakt tussen de leidingen/doorvoeren waarbij zoveel mogelijk wapening kan doorlopen

AANDUIDINGEN

- BK = beton kolom
- BB = beton balk
- PB = prefab beton kolom
- PB = prefab beton balk
- KK = kokerprofiel koud getrokken
- KW = kokerprofiel warm gewalst
- B = buisprofiel
- BW = brandwerende afwerking

LEGENDA

- beton op de vloer; in het werk gestort
- beton op de vloer; prefab
- metalwerk op de vloer; kalkzandsteen
- constructie onder de vloer
- overspanningsrichting vloer
- kolom boven vloer
- kolom onder vloer
- P = vloerpeil (mm)
- D = dikte vloer (mm)

Deze tekening is gebaseerd op:
 Model Aveco de Bondt: MKW_K_CON_Adb_R21214570
 Constructieve uitgangspunten Aveco de Bondt: 214570_Adb_RAP_K1a-0001
 Onderlegger: MKW_K_BWK_HFB_R21

3.0 15-12-2023	toevoeging; wijzigingen kelder ivm aanpassing naar openbaar
2.0 16-06-2023	eerste uitgave; def.
1.0 06-03-2023	eerste uitgave
Datum:	Omschrijving:
Project:	Marktwaartier West te Amsterdam
Onderdeel:	Begane grondvloer fase 1b
Architect:	HFB
Aannemer:	Kondor Wessels Amsterdam
Opdrachtgever:	Marktwaartier CV

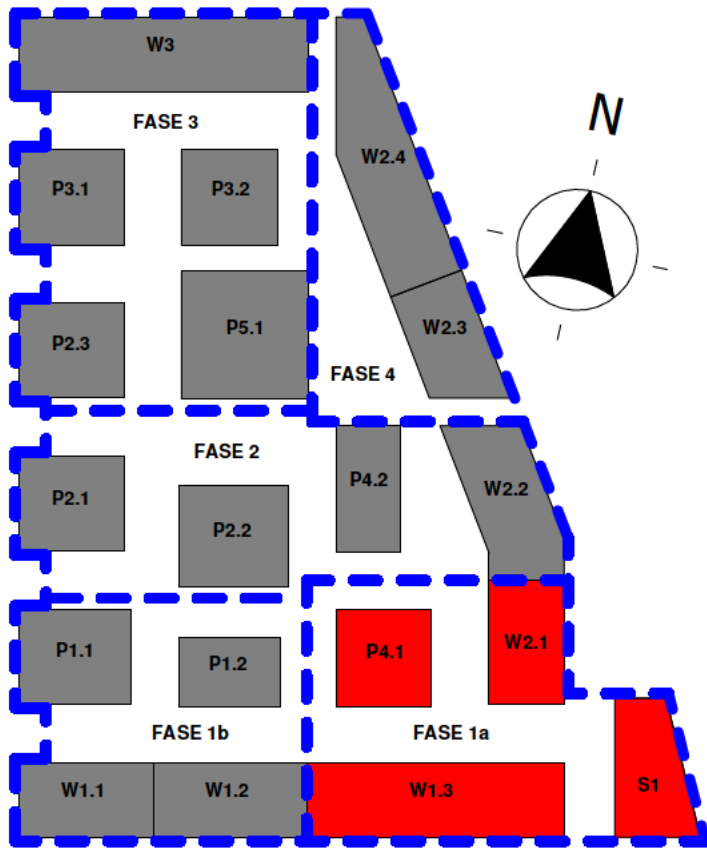

keyplan fase 1a

1 : 2000

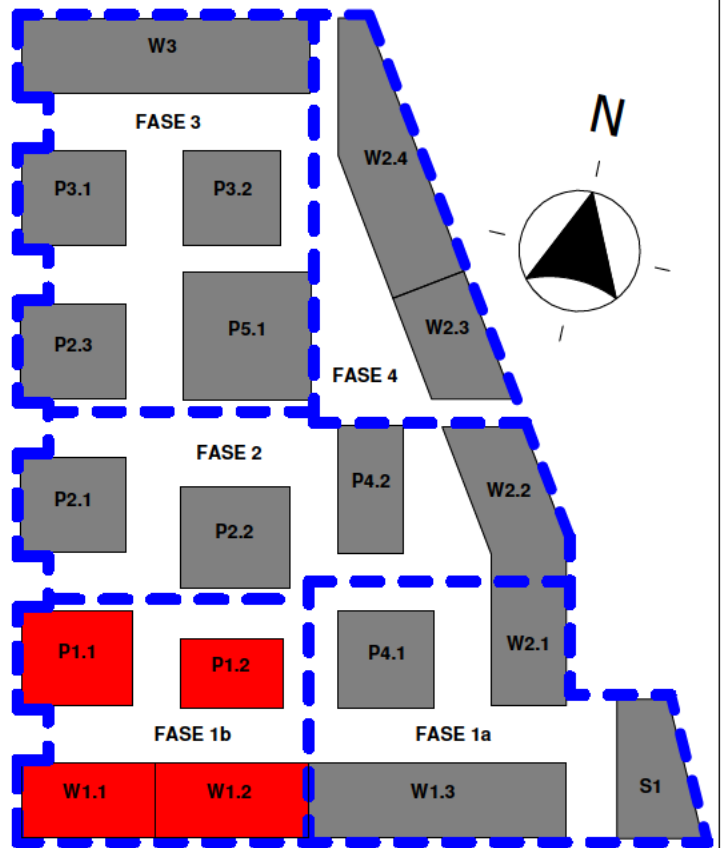

keyplan fase 1b

1 : 2000

[Redacted text]

8.0	15-12-2023	toevoeging; wijzigingen kelder ivm aanpassing naar openbaar
7.0	16-06-2023	eerste uitgave; def.
6.0	06-03-2023	toevoeging; details fase 1b
5.0	23-11-2022	eerste uitgave; def.
4.0	18-07-2022	toevoeging; blok S1 aanpassing

Datum:	Omschrijving:
--------	---------------

Project | [Redacted]

Onderdeel | [Redacted]

Architect | [Redacted]

Aannemer | [Redacted]

Opdrachtgever : [Redacted]

Postbus 64, 7451 CH Holten T +31 88 004 82 12 www.aveccodebondt.nl  onderzoekt ontwerpt adviseert	Projectleider: [Redacted] fase: [Redacted]
	Constructeur: [Redacted] status: [Redacted]
	Modelleur: [Redacted] schaal: [Redacted]
	[Redacted] projectnummer: [Redacted]
	Controlerend model: [Redacted] Formaat: A4 Tekeningnummer: [Redacted]

Tekeningenlijst details bovenbouw fase 1a/b

Tekeningnr.	Status	Omschrijving	Datum	Rev	Wijz.
D-0.01	Definitief	Detail 0.01	11-05-2022	4.0	15-12-2023
D-0.02	Definitief	Detail 0.02	11-05-2022	4.0	15-12-2023
D-0.03	Definitief	Detail 0.03	11-05-2022	4.0	15-12-2023
D-0.04	Definitief	Detail 0.04	11-05-2022	4.0	15-12-2023
D-0.05	Definitief	Detail 0.05	11-05-2022	4.0	15-12-2023
D-0.06	Definitief	Detail 0.06	11-05-2022	4.0	15-12-2023
D-0.07	Definitief	Detail 0.07	11-05-2022	4.0	15-12-2023
D-0.08	Definitief	Detail 0.08	11-05-2022	4.0	15-12-2023
D-0.09	Definitief	Detail 0.09	11-05-2022	5.0	15-12-2023
D-0.10	Definitief	Detail 0.10	11-05-2022	5.0	15-12-2023
D-0.11	Definitief	Detail 0.11	11-05-2022	5.0	15-12-2023
D-0.12	Definitief	Detail 0.12	11-05-2022	5.0	15-12-2023
D-0.13	Definitief	Detail 0.13	11-05-2022	5.0	15-12-2023
D-0.14	Definitief	Detail 0.14	11-05-2022	5.0	15-12-2023
D-0.15	Definitief	Detail 0.15	25-05-2022	4.0	15-12-2023
D-0.16	Definitief	Detail 0.16	25-05-2022	4.0	15-12-2023
D-0.17	Definitief	Detail 0.17	25-05-2022	4.0	15-12-2023
D-0.18	Definitief	Detail 0.18	25-05-2022	4.0	15-12-2023
D-0.19	Definitief	Detail 0.19	25-05-2022	4.0	15-12-2023
D-0.20	Definitief	Detail 0.20	25-05-2022	4.0	15-12-2023
D-0.21	Definitief	Detail 0.21	25-05-2022	4.0	15-12-2023
D-0.22	Definitief	Detail 0.22	15-07-2022	4.0	15-12-2023
D-0.23	Definitief	Detail 0.23	15-07-2022	4.0	15-12-2023
D-0.24	Definitief	Detail 0.24	15-07-2022	4.0	15-12-2023
D-0.25	Definitief	Detail 0.25	15-07-2022	4.0	15-12-2023
D-0.26	Definitief	Detail 0.26	15-07-2022	4.0	15-12-2023
D-0.27	Definitief	Detail 0.27	15-07-2022	4.0	15-12-2023
D-0.28	Definitief	Detail 0.28	15-07-2022	4.0	15-12-2023
D-0.29	Definitief	Detail 0.29	15-07-2022	4.0	15-12-2023
D-0.30	Definitief	Detail 0.30	15-07-2022	4.0	15-12-2023
D-0.31	Definitief	Detail 0.31	15-07-2022	4.0	15-12-2023
D-0.32	Definitief	Detail 0.32	15-07-2022	4.0	15-12-2023
D-0.33	Definitief	Detail 0.33	15-07-2022	4.0	15-12-2023
D-0.34	Definitief	Detail 0.34	15-07-2022	4.0	15-12-2023
D-0.35	Definitief	Detail 0.35	15-07-2022	4.0	15-12-2023
D-0.36	Definitief	Detail 0.36	15-07-2022	4.0	15-12-2023
D-0.37	Definitief	Detail 0.37	15-07-2022	4.0	15-12-2023
D-0.38	Definitief	Detail 0.38	15-07-2022	4.0	15-12-2023
D-0.39	Definitief	Detail 0.39	15-07-2022	4.0	15-12-2023
D-0.40	Definitief	Detail 0.40	15-07-2022	4.0	15-12-2023
D-0.41	Definitief	Detail 0.41	15-07-2022	4.0	15-12-2023
D-0.42	Definitief	Detail 0.42	15-07-2022	4.0	15-12-2023
D-0.43	Definitief	Detail 0.43	15-07-2022	4.0	15-12-2023
D-0.44	Definitief	Detail 0.44	15-07-2022	4.0	15-12-2023
D-0.45	Definitief	Detail 0.45	15-07-2022	4.0	15-12-2023
D-0.46	Definitief	Detail 0.46	15-07-2022	4.0	15-12-2023
D-0.47	Definitief	Detail 0.47	15-07-2022	4.0	15-12-2023
D-0.48	Definitief	Detail 0.48	15-07-2022	4.0	15-12-2023
D-0.49	Definitief	Detail 0.49	15-07-2022	4.0	15-12-2023

 <p>Aveco de Bondt onderzoekt ontwerpt adviseert</p>	Project : Marktkwartier West te Amsterdam				
	Schaal :	Datum :	Onderdeel : overzicht details onderbouw fase 1a/b		
	Postbus 64, 7451 CH Holten T +31(0)548 85 33 33 E info@avecodebondt.nl I www.avecodebondt.nl	1.0	11-05-2022	Formaat : A4	Status : Definitief
		6.0	06-03-2023	Projectnummer:	Tekeningnummer:
7.0	16-06-2023	214570	D-01-D3-01i		

Tekeningenlijst details bovenbouw fase 1b

Tekeningnr.	Status	Omschrijving	Datum	Rev	Wijz.
D-0.50	Definitief	Detail 0.50	06-03-2023	3.0	15-12-2023
D-0.51	Definitief	Detail 0.51	06-03-2023	3.0	15-12-2023
D-0.52	Definitief	Detail 0.52	06-03-2023	3.0	15-12-2023
D-0.53	Definitief	Detail 0.53	06-03-2023	3.0	15-12-2023
D-0.54	Definitief	Detail 0.54	06-03-2023	3.0	15-12-2023
D-0.55	Definitief	Detail 0.55	06-03-2023	3.0	15-12-2023
D-0.56	Definitief	Detail 0.56	06-03-2023	3.0	15-12-2023
D-0.57	Definitief	Detail 0.57	06-03-2023	3.0	15-12-2023
D-0.58	Definitief	Detail 0.58	06-03-2023	3.0	15-12-2023
D-0.59	Definitief	Detail 0.59	06-03-2023	3.0	15-12-2023
D-0.60	Definitief	Detail 0.60	06-03-2023	3.0	15-12-2023
D-0.61	Definitief	Detail 0.61	06-03-2023	3.0	15-12-2023
D-0.62	Definitief	Detail 0.62	06-03-2023	3.0	15-12-2023
D-0.63	Definitief	Detail 0.63	06-03-2023	3.0	15-12-2023
D-0.64	Definitief	Detail 0.64	06-03-2023	3.0	15-12-2023
D-0.65	Definitief	Detail 0.65	06-03-2023	3.0	15-12-2023
D-0.66	Definitief	Detail 0.66	06-03-2023	3.0	15-12-2023
D-0.67	Definitief	Detail 0.67	06-03-2023	3.0	15-12-2023
D-0.68	Definitief	Detail 0.68	06-03-2023	3.0	15-12-2023
D-0.69	Definitief	Detail 0.69	06-03-2023	3.0	15-12-2023
D-0.70	Definitief	Detail 0.70	06-03-2023	3.0	15-12-2023
D-0.71	Definitief	Detail 0.71	06-03-2023	3.0	15-12-2023
D-0.72	Definitief	Detail 0.72	06-03-2023	3.0	15-12-2023
D-0.73	Definitief	Detail 0.73	06-03-2023	3.0	15-12-2023
D-0.74	Definitief	Detail 0.74	06-03-2023	3.0	15-12-2023
D-0.75	Definitief	Detail 0.75	06-03-2023	3.0	15-12-2023
D-0.76	Definitief	Detail 0.76	06-03-2023	3.0	15-12-2023
D-0.77	Definitief	Detail 0.77	06-03-2023	3.0	15-12-2023
D-0.78	Definitief	Detail 0.78	06-03-2023	3.0	15-12-2023
D-0.79	Definitief	Detail 0.79	06-03-2023	3.0	15-12-2023
D-0.80	Definitief	Detail 0.80	06-03-2023	3.0	15-12-2023
D-0.81	Definitief	Detail 0.81	06-03-2023	3.0	15-12-2023
D-0.82	Definitief	Detail 0.82	06-03-2023	3.0	15-12-2023
D-0.83	Definitief	Detail 0.83	06-03-2023	3.0	15-12-2023
D-0.84	Definitief	Detail 0.84	06-03-2023	3.0	15-12-2023
D-0.85	Definitief	Detail 0.85	06-03-2023	3.0	15-12-2023
D-0.86	Definitief	Detail 0.86	06-03-2023	3.0	15-12-2023
D-0.87	Definitief	detail 0.87	16-06-2023	2.0	15-12-2023
D-0.88	Definitief	detail 0.88	16-06-2023	2.0	15-12-2023

 <p>onderzoekt ontwerpt adviseert</p>	Project : Marktkwartier West te Amsterdam			
	Schaal :	Datum :	Onderdeel : overzicht details onderbouw fase 1b	
	Postbus 64, 7451 CH Holten T +31(0)548 85 33 33 E info@avecodebondt.nl I www.avecodebondt.nl	1.0	03/01/23	Formaat : A4
	2.0	16-06-2023	Projectnummer: 214570	Tekeningnummer: D-01-D3-03i

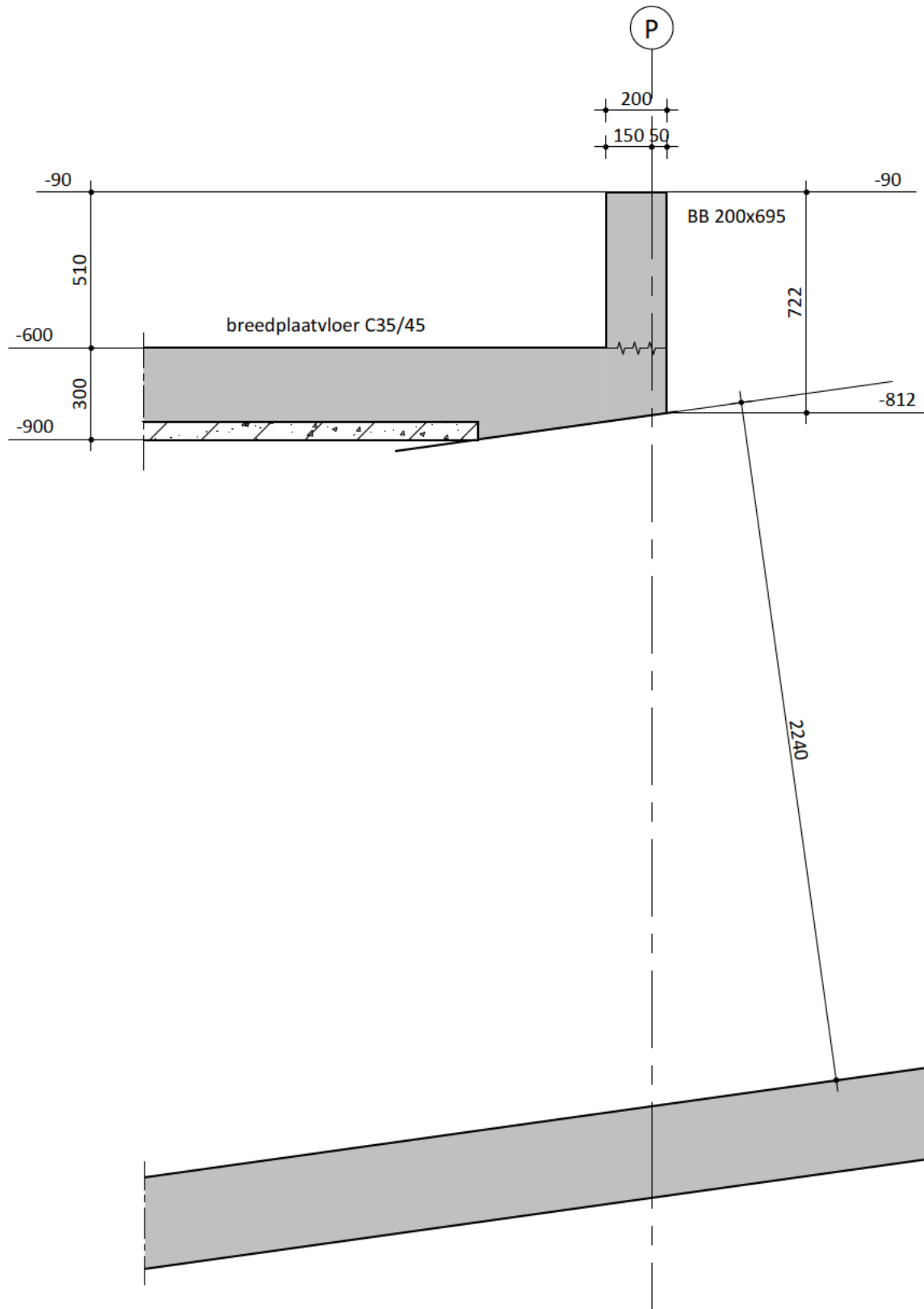

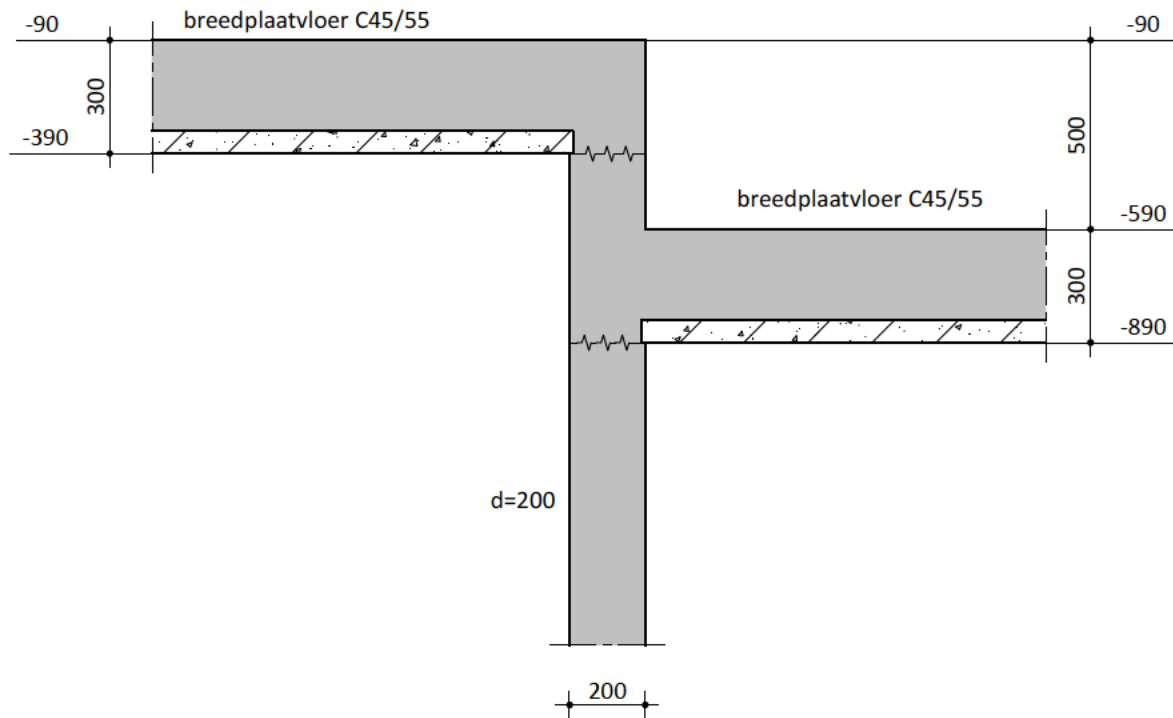

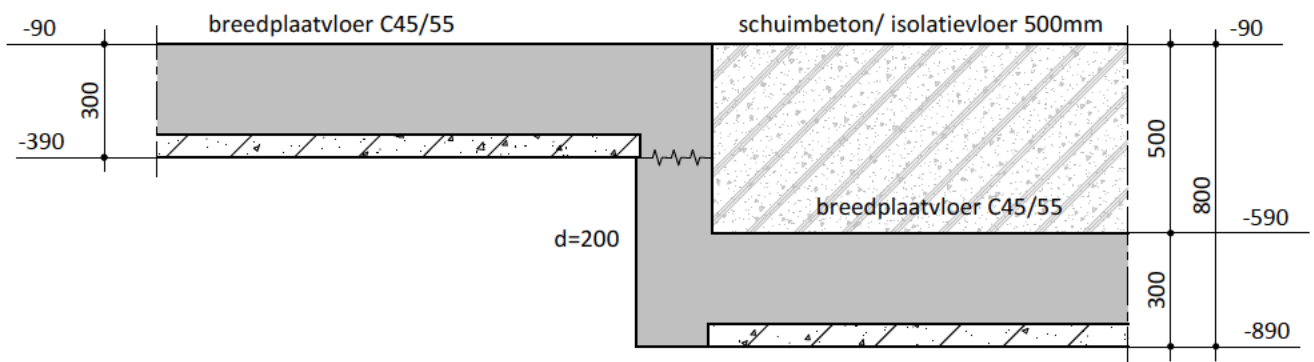

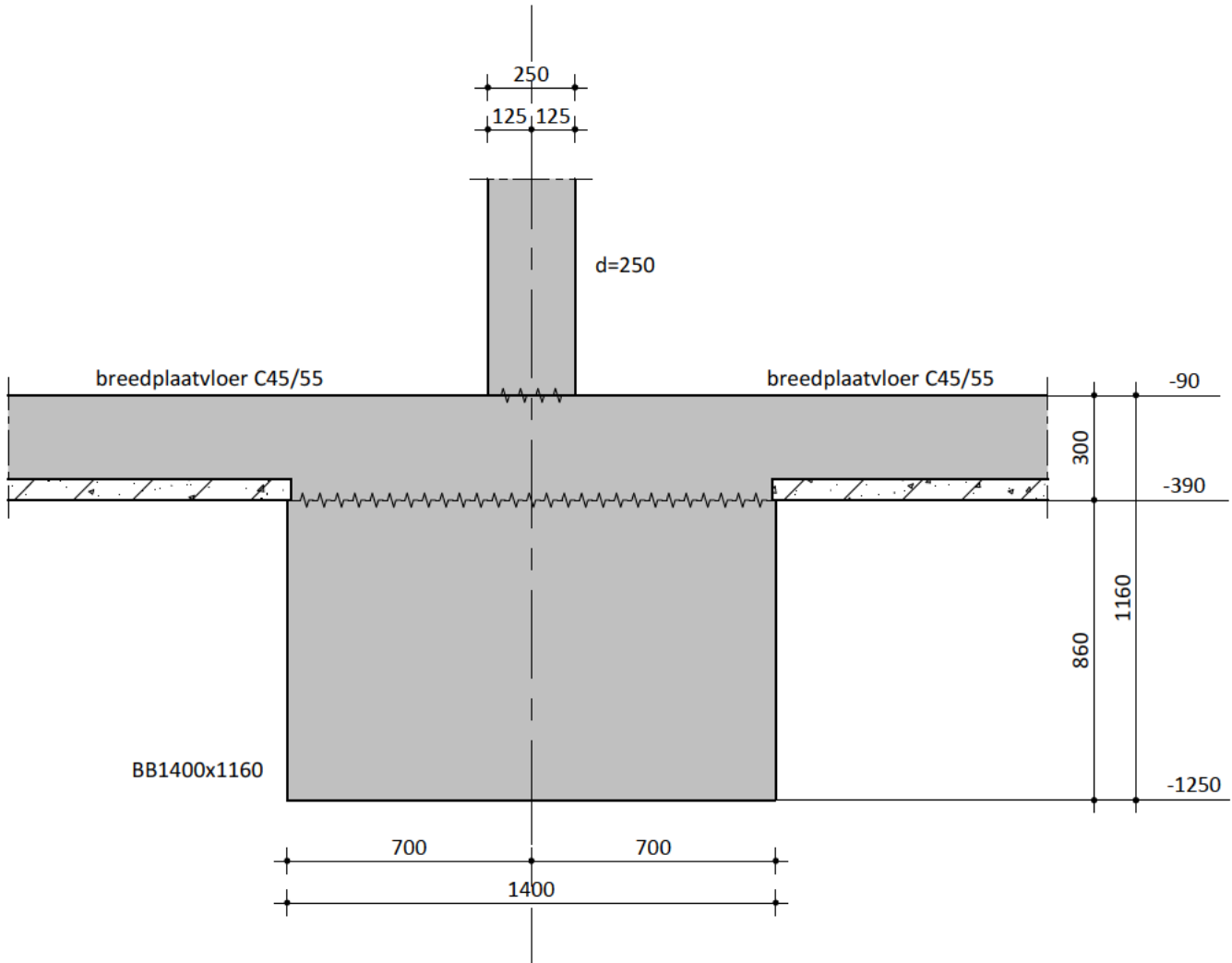

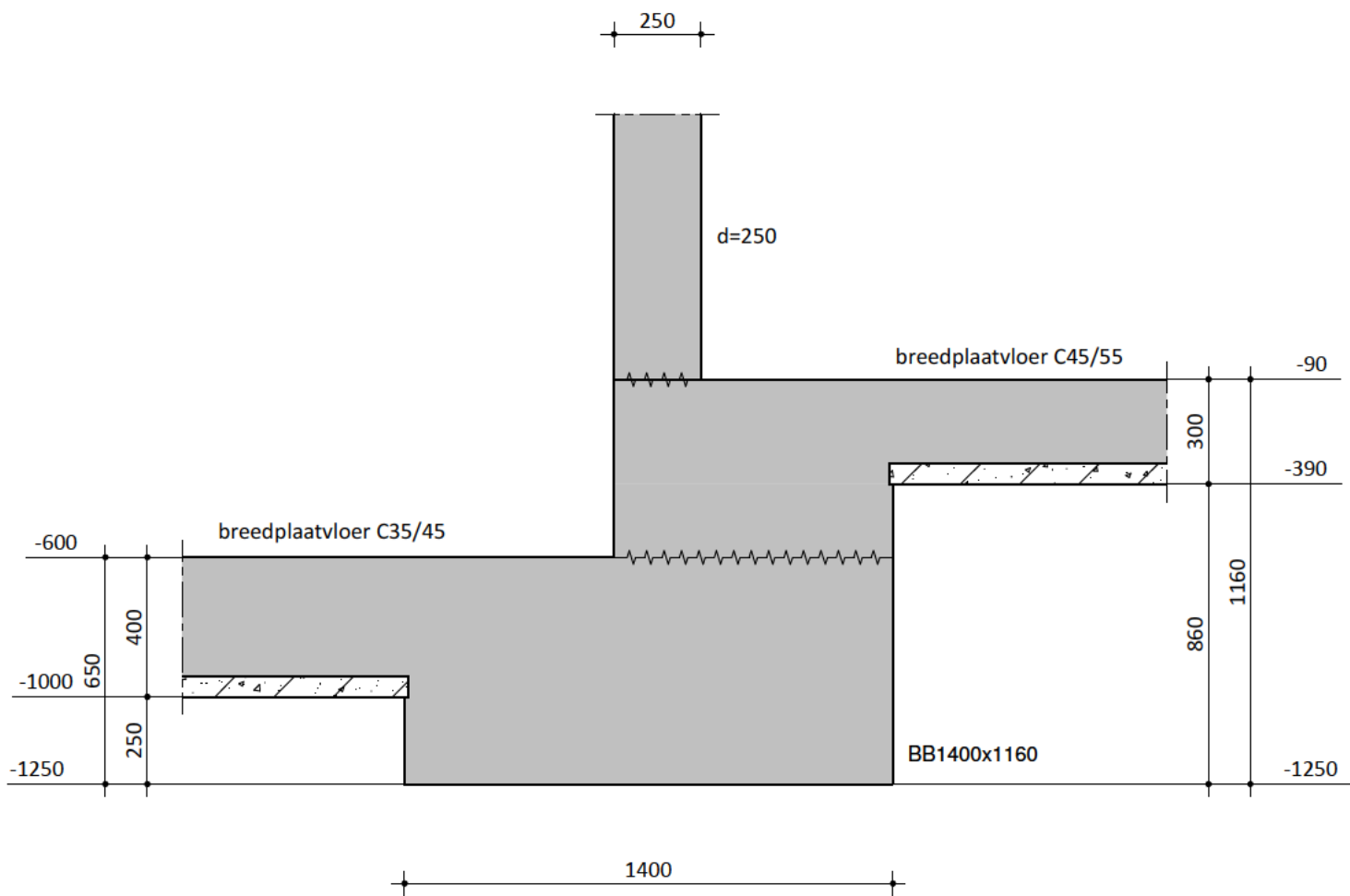



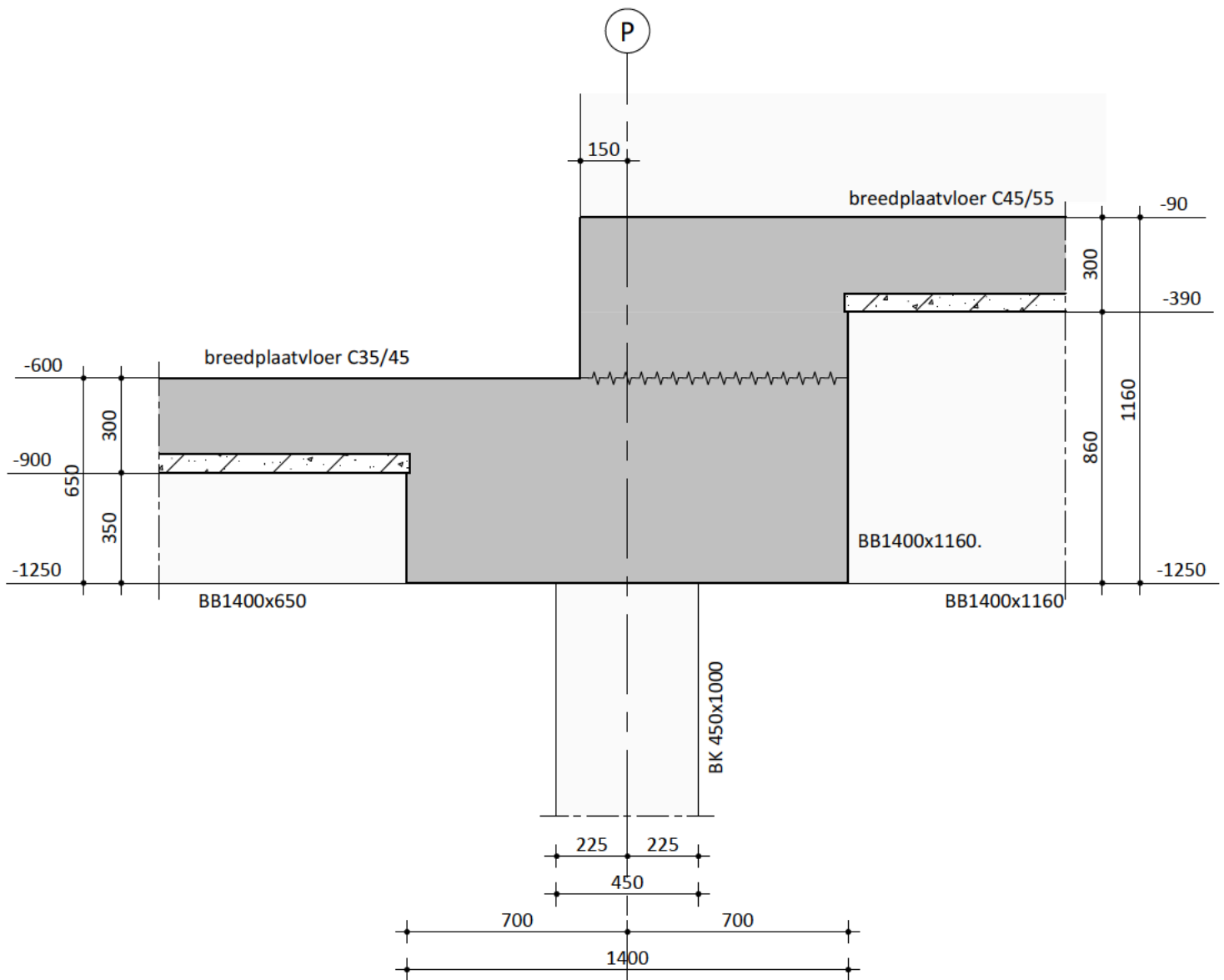

 <p>onderzoekt ontwerpt adviseert</p>	Project : Marktkwartier West te Amsterdam			
	Schaal : 1 : 20	Datum :	Onderdeel : Detail 0.05	
	Postbus 64, 7451 CH Holten T +31(0)548 85 33 33 E info@avecodebondt.nl I www.avecodebondt.nl	1.0	11-05-2022	Formaat : A4
		3.0	16-06-2023	Projectnummer:
4.0	15-12-2023	214570	Status : Definitief	
			Tekeningnummer:	
			D-0.05	

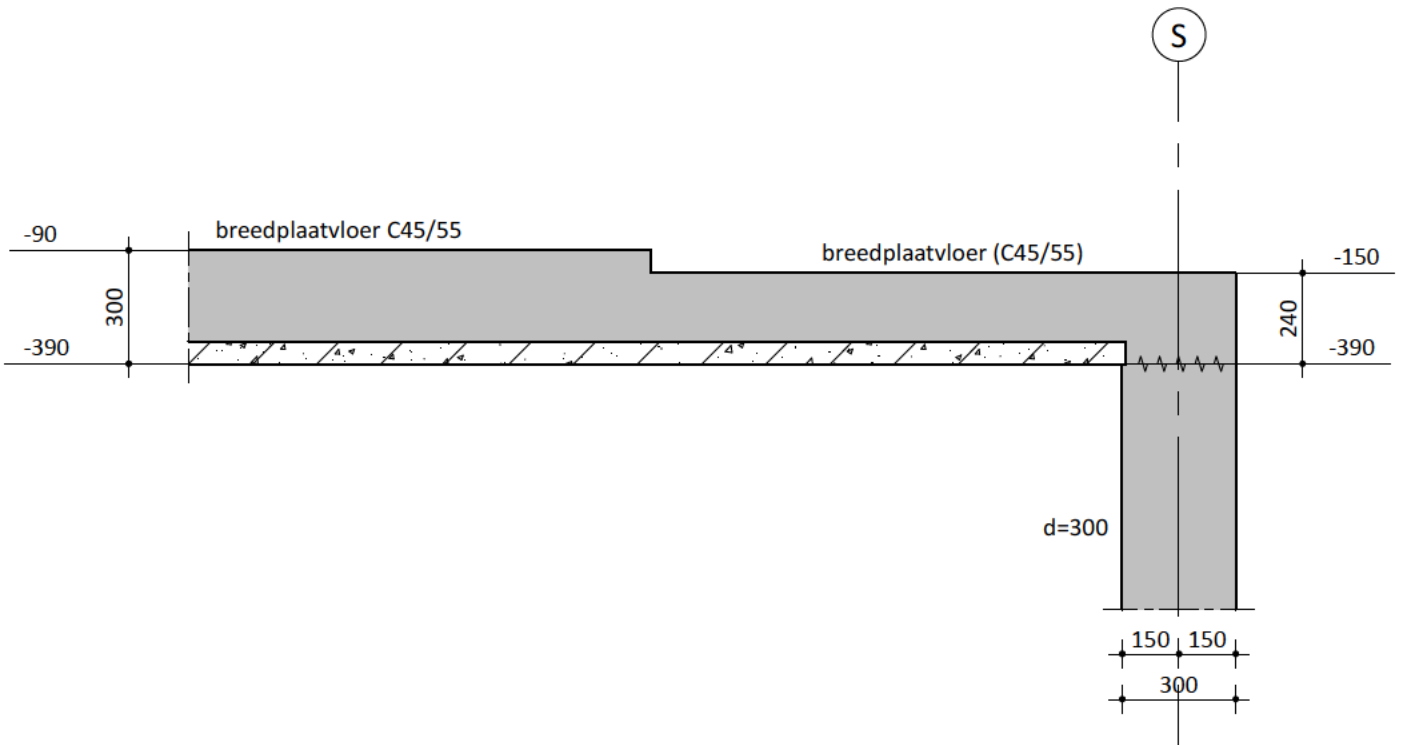

 <p>onderzoekt ontwerpt adviseert</p>	Project : Marktkwartier West te Amsterdam			
	Schaal : 1 : 20	Datum :	Onderdeel : Detail 0.06	
	Postbus 64, 7451 CH Holten T +31(0)548 85 33 33 E info@avecodebondt.nl I www.avecodebondt.nl	1.0	11-05-2022	Formaat : A4
		3.0	16-06-2023	Projectnummer:
4.0	15-12-2023	214570	Status : Definitief	
			Tekeningnummer: D-0.06	

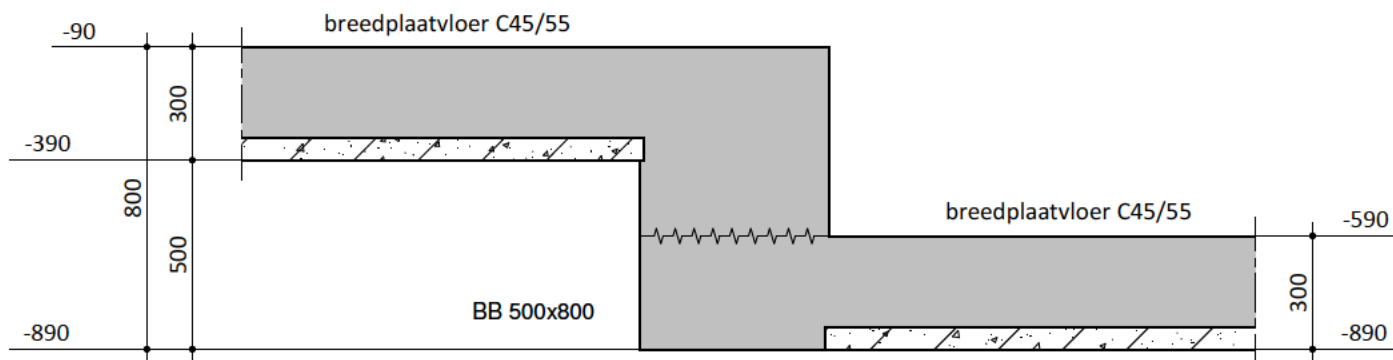



 <p>Avecode Bondt onderzoekt ontwerpt adviseert</p>	Project : Marktkwartier West te Amsterdam				
	Schaal : 1 : 20		Datum :	Onderdeel : Detail 0.08	
	Postbus 64, 7451 CH Holten T +31(0)548 85 33 33 E info@avecodebondt.nl I www.avecodebondt.nl	1.0	11-05-2022	Formaat : A4	Status : Definitief
		3.0	16-06-2023	Projectnummer:	Tekeningnummer:
	4.0	15-12-2023	214570	D-0.08	

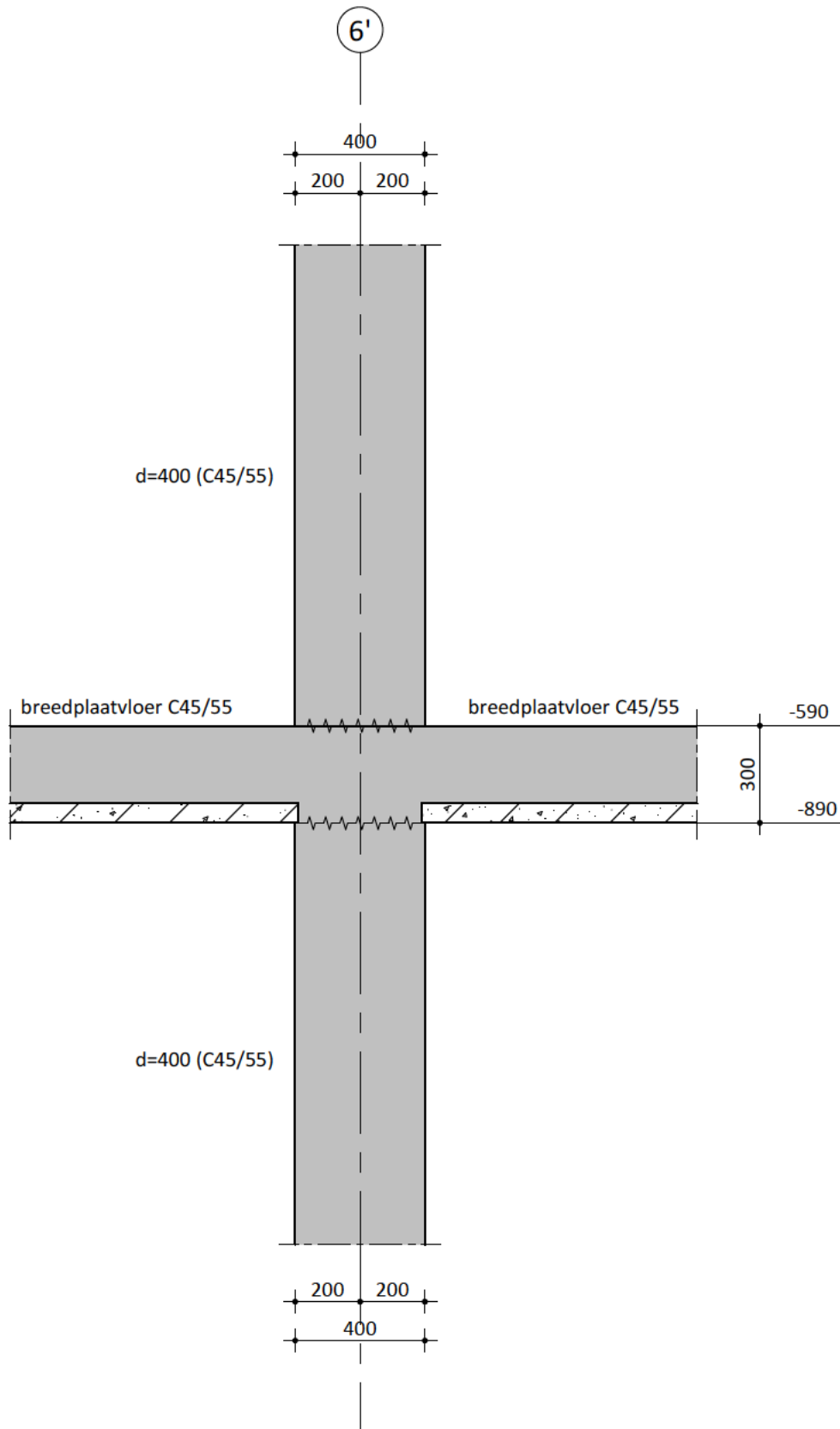

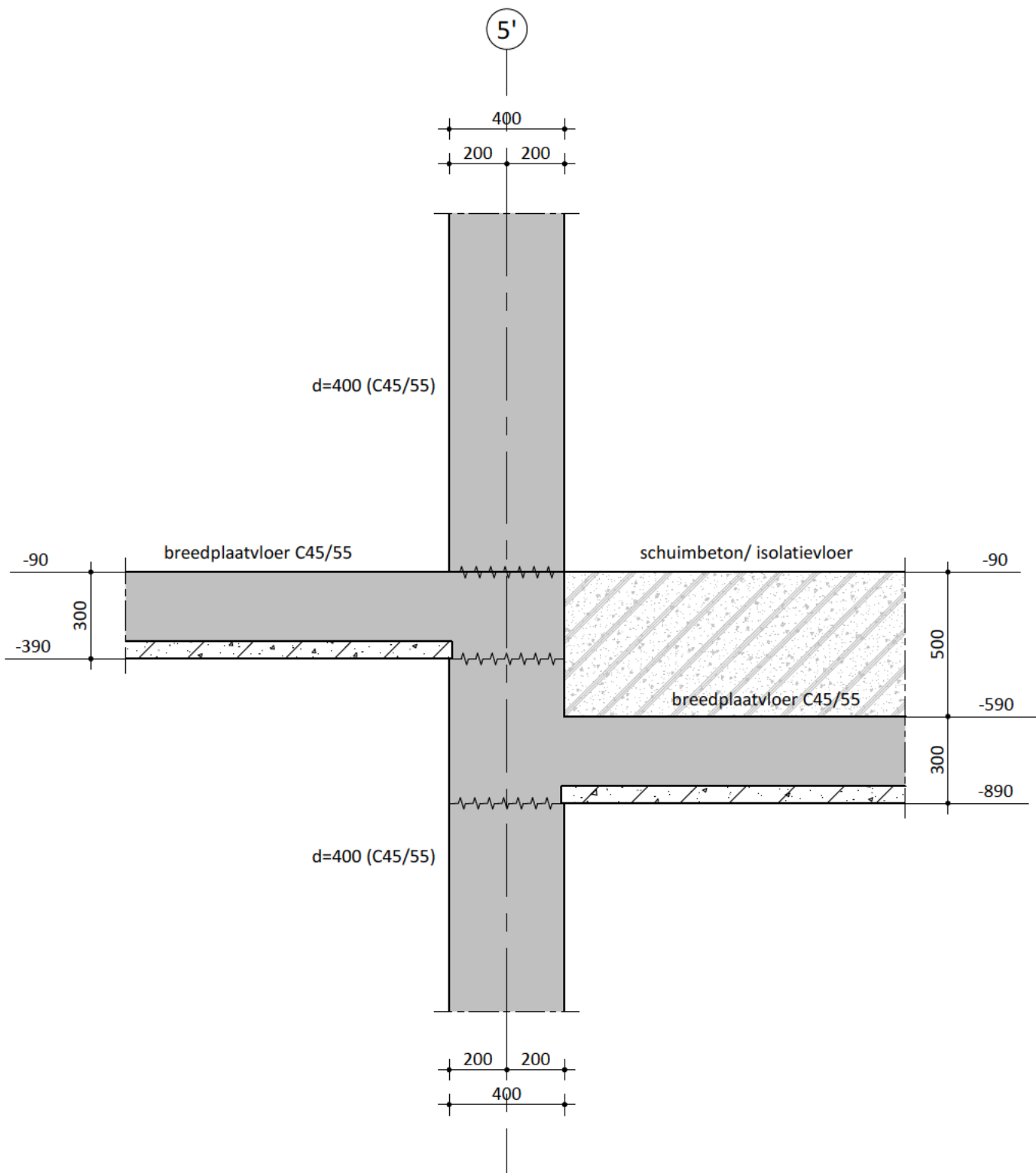

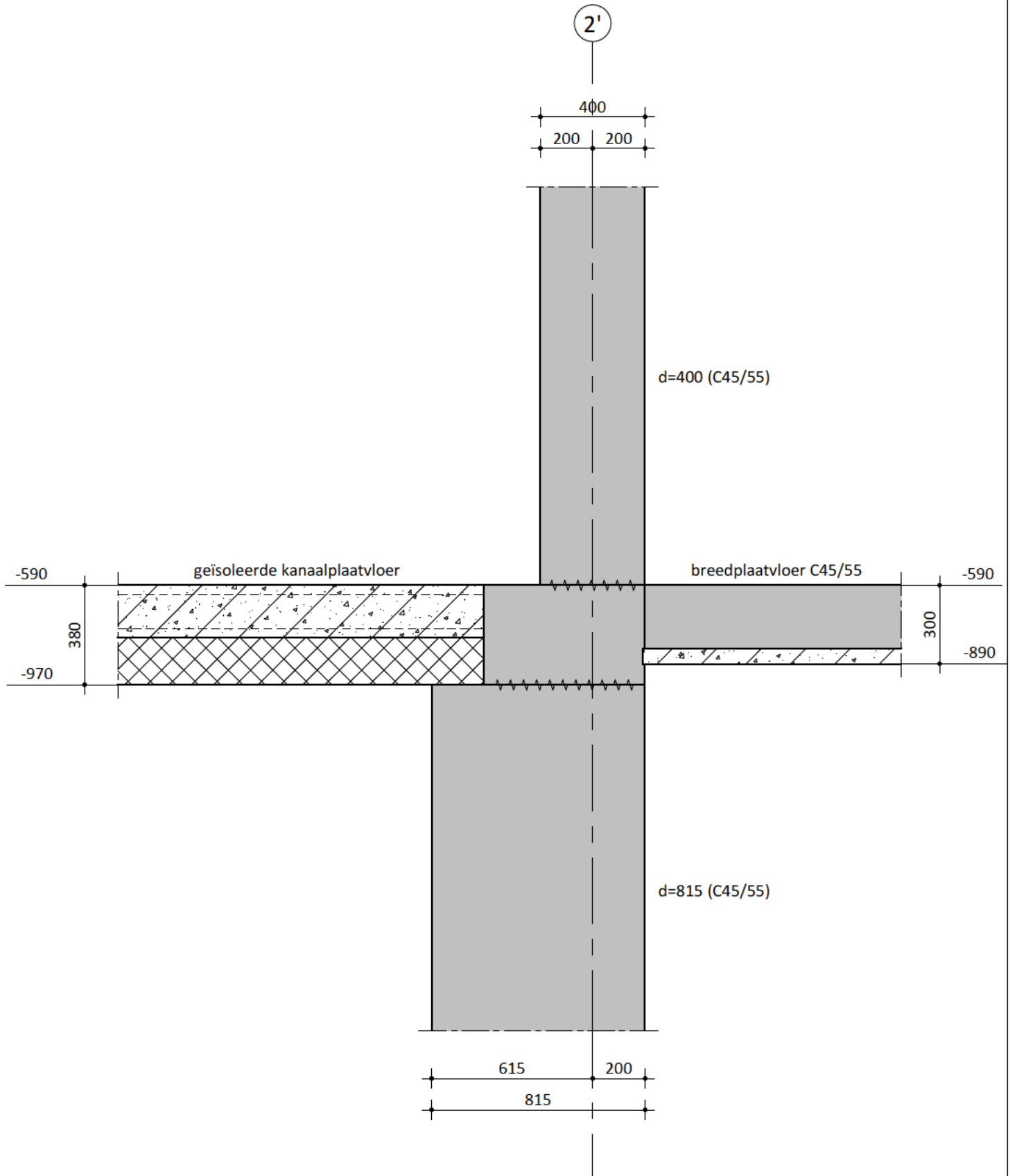

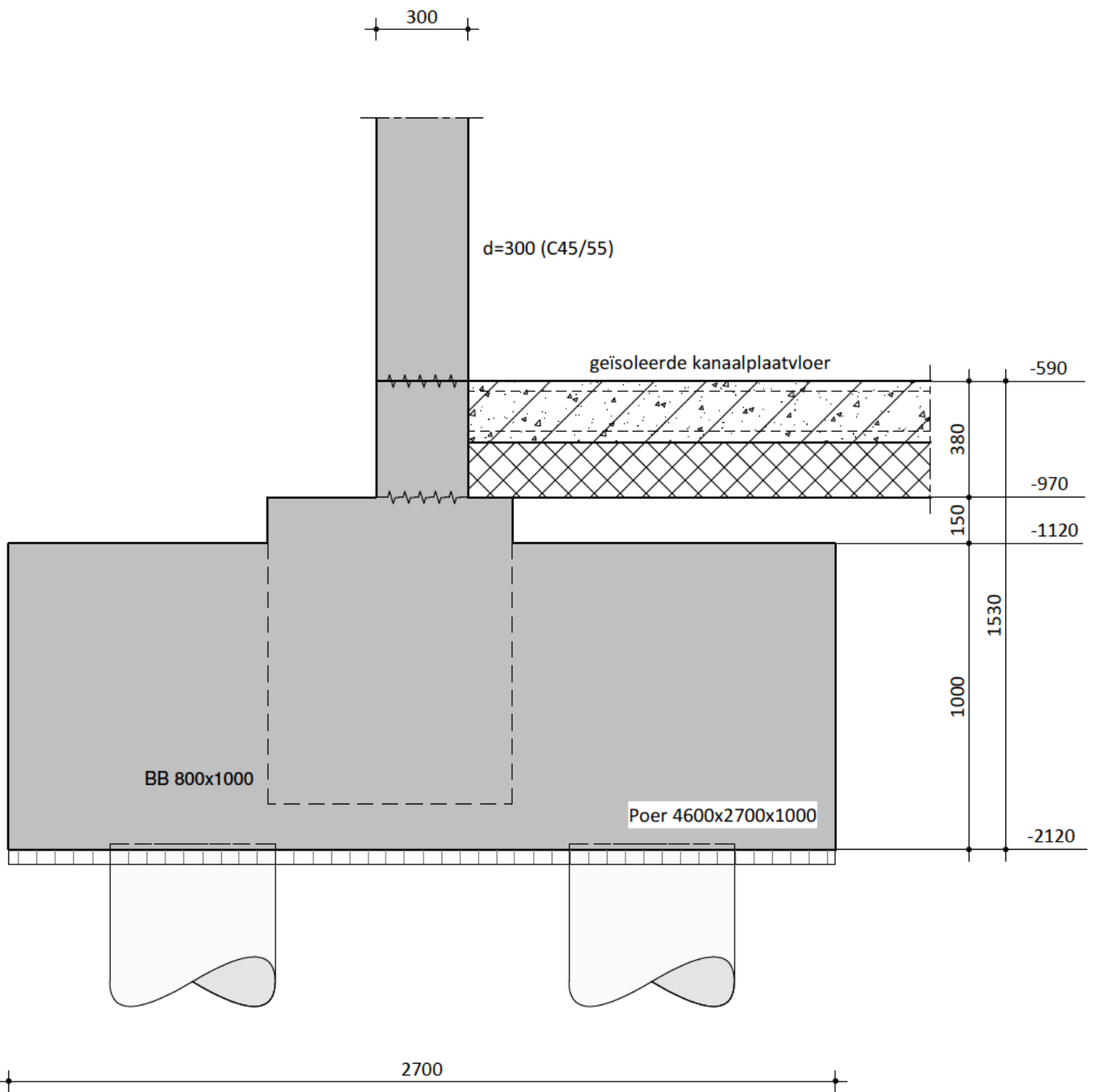

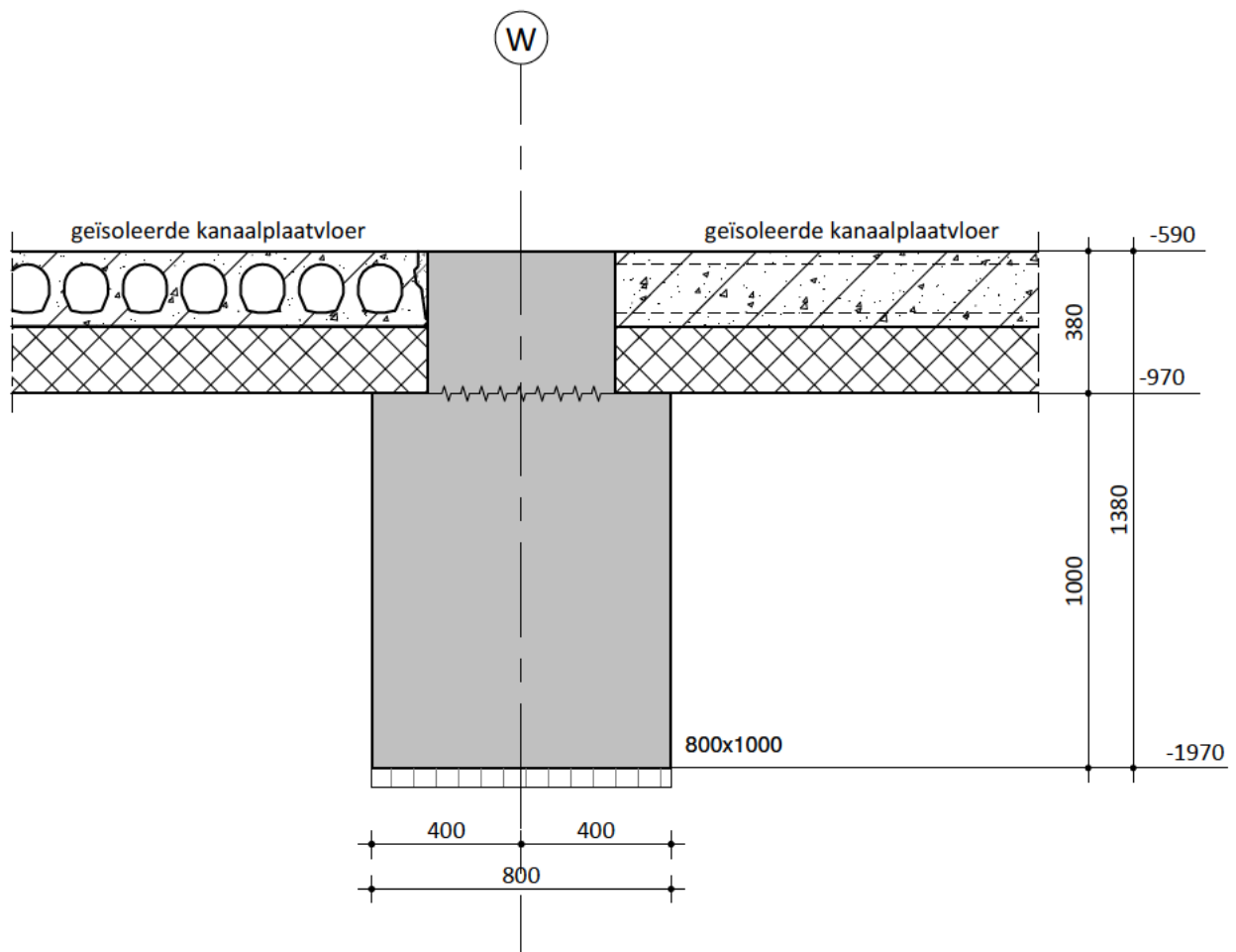

Project : Marktkwartier West te Amsterdam			
Schaal : 1 : 20	Datum :	Onderdeel : Detail 0.13	
Postbus 64, 7451 CH Holten T +31(0)548 85 33 33 E info@avecodebondt.nl I www.avecodebondt.nl	1.0	11-05-2022	Formaat : A4
	4.0	16-06-2023	Projectnummer:
	5.0	15-12-2023	214570
			Status : Definitief
			Tekeningnummer: D-0.13

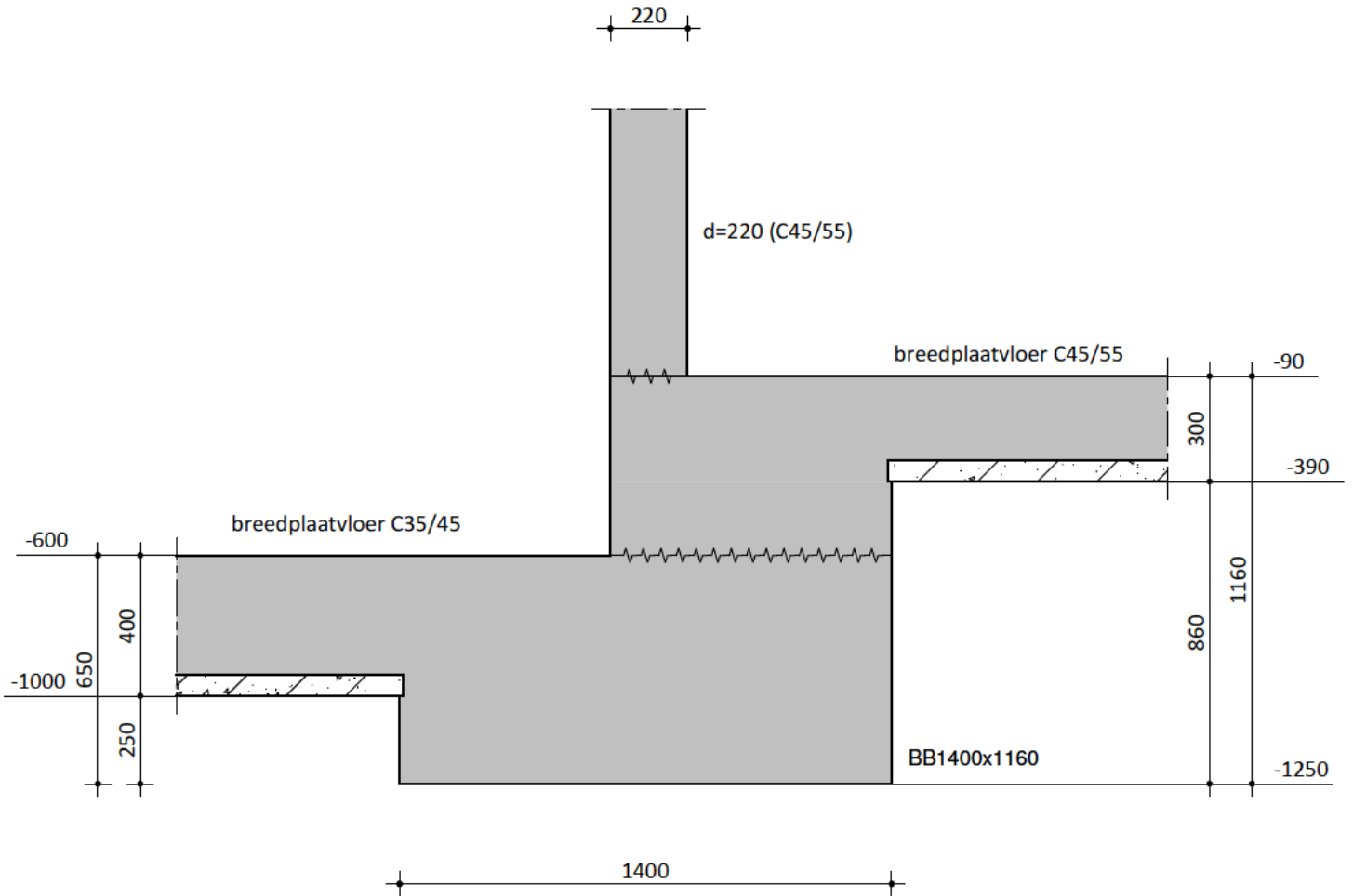



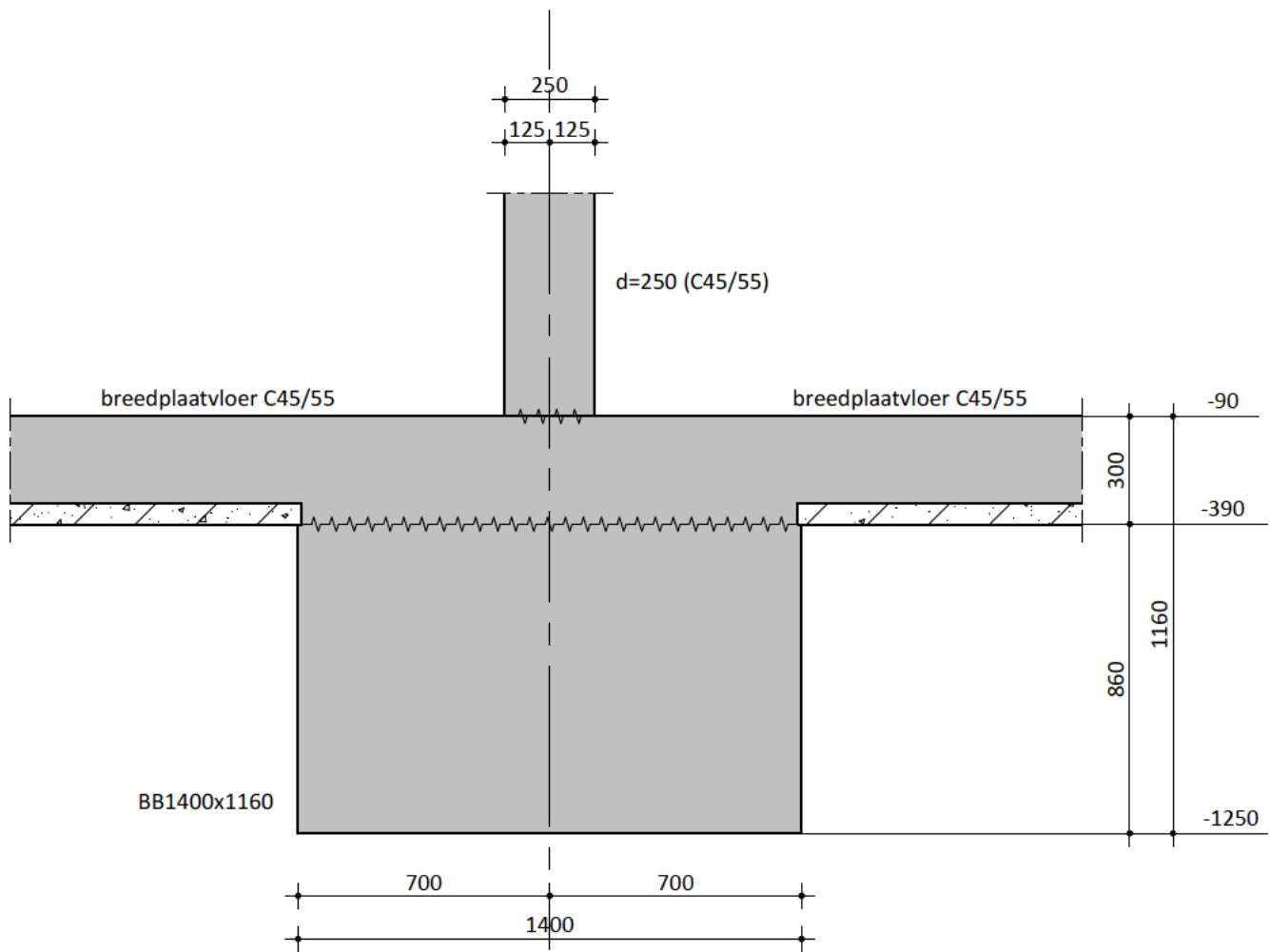

 <p>onderzoekt ontwerpt adviseert</p>	Project : Marktkwartier West te Amsterdam			
	Schaal : 1 : 20	Datum :	Onderdeel : Detail 0.15	
	Postbus 64, 7451 CH Holten T +31(0)548 85 33 33 E info@avecodebondt.nl I www.avecodebondt.nl	1.0	25-05-2022	Formaat : A4
		3.0	16-06-2023	Projectnummer:
4.0	15-12-2023	214570	Status : Definitief	
			Tekeningnummer: D-0.15	

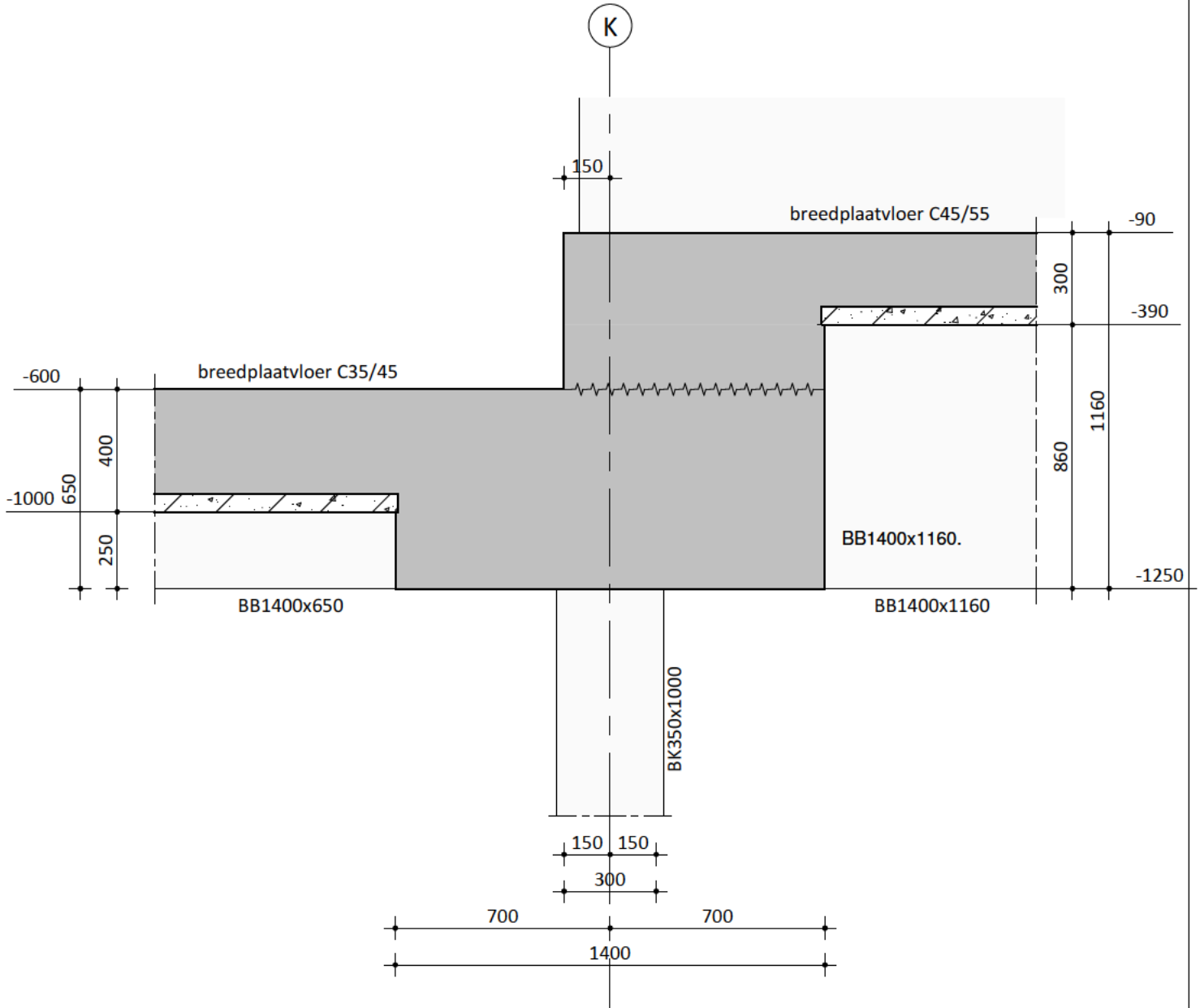

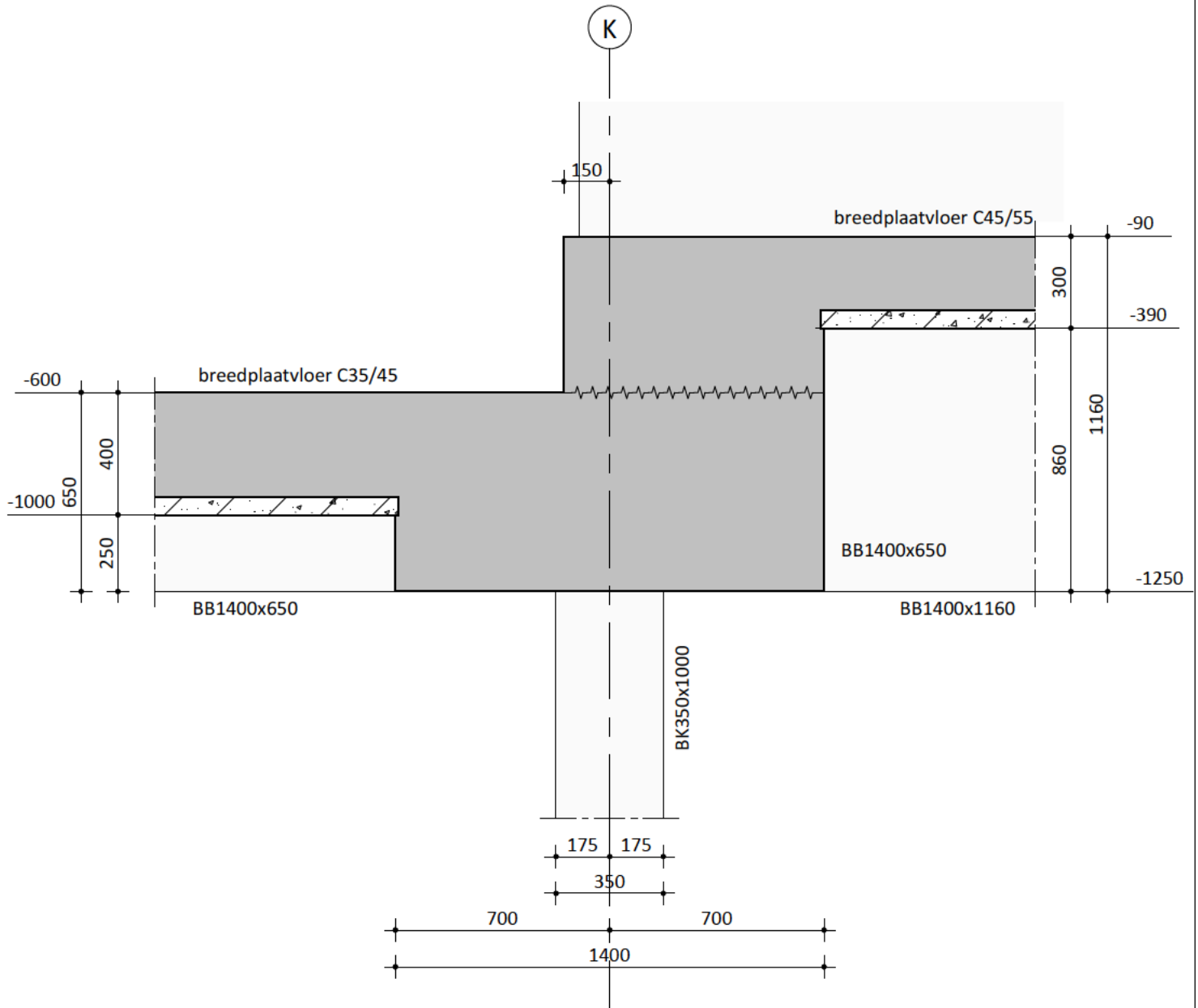



 <p>onderzoekt ontwerpt adviseert</p>	Project : Marktkwartier West te Amsterdam			
	Schaal : 1 : 20	Datum :	Onderdeel : Detail 0.18	
	Postbus 64, 7451 CH Holten T +31(0)548 85 33 33 E info@avecodebondt.nl I www.avecodebondt.nl	1.0	25-05-2022	Formaat : A4
		3.0	16-06-2023	Projectnummer:
4.0	15-12-2023	214570	Status : Definitief	
			Tekeningnummer: D-0.18	

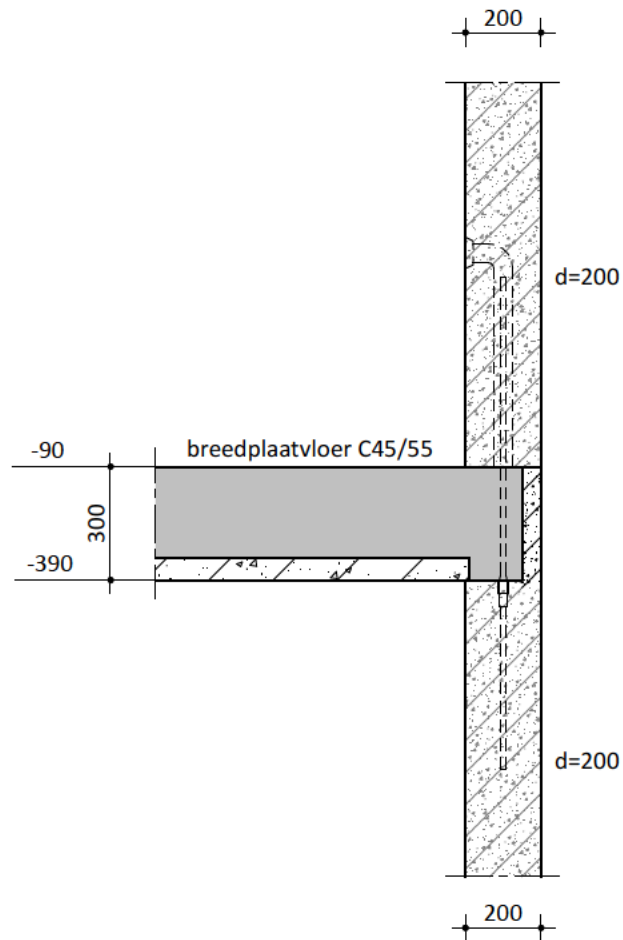

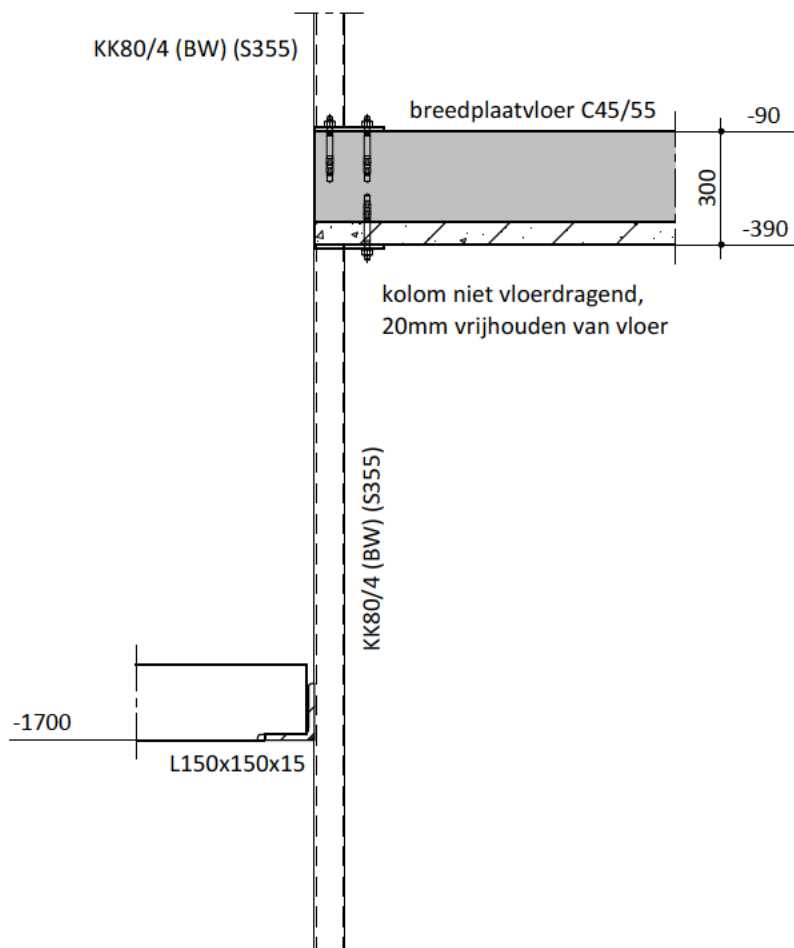

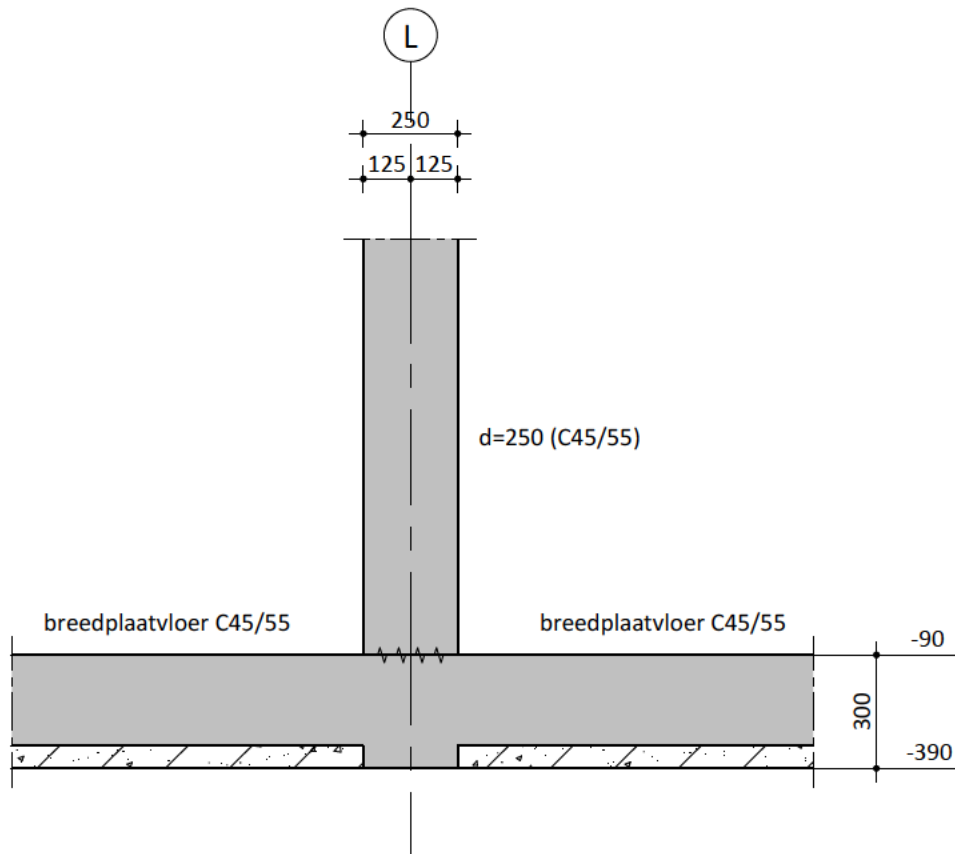

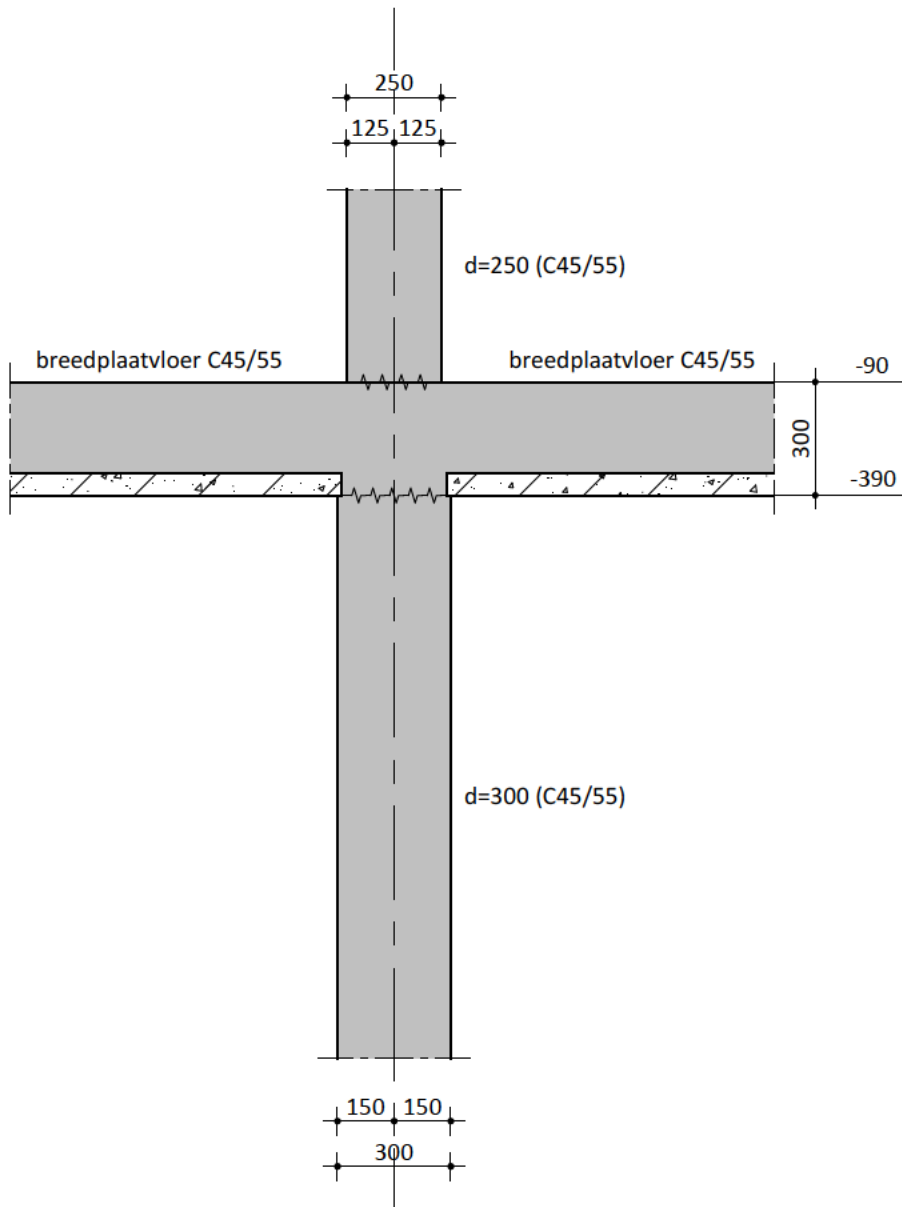

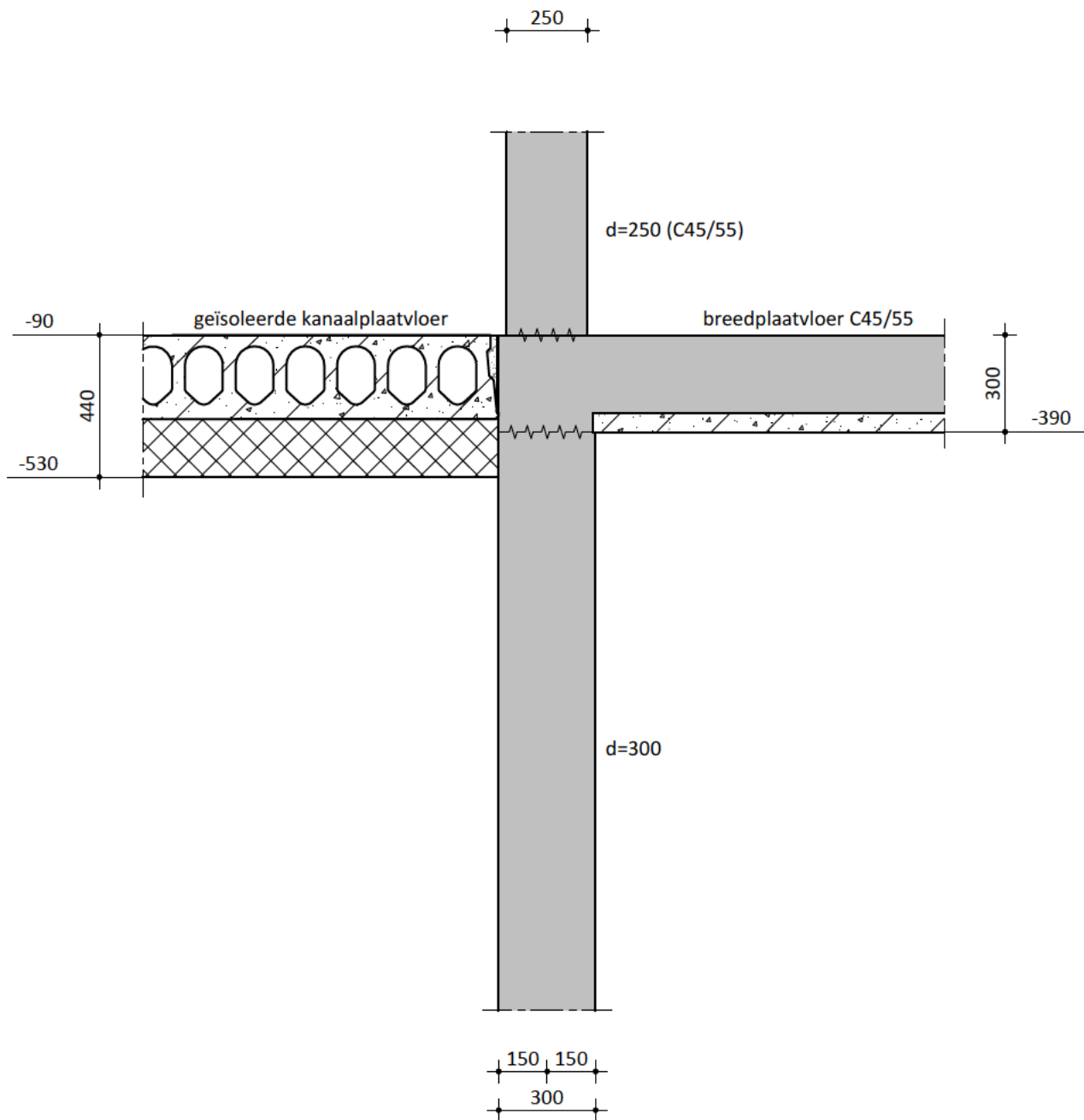

 <p>Aveco de Bondt onderzoekt ontwerpt adviseert</p>	Project : Marktkwartier West te Amsterdam			
	Schaal : 1 : 20	Datum :	Onderdeel : Detail 0.24	
	Postbus 64, 7451 CH Holten T +31(0)548 85 33 33 E info@avecodebondt.nl I www.avecodebondt.nl	1.0	15-07-2022	Formaat : A4
		3.0	16-06-2023	Projectnummer: 214570
4.0	15-12-2023	Status : Definitief	Tekeningnummer: D-0.24	

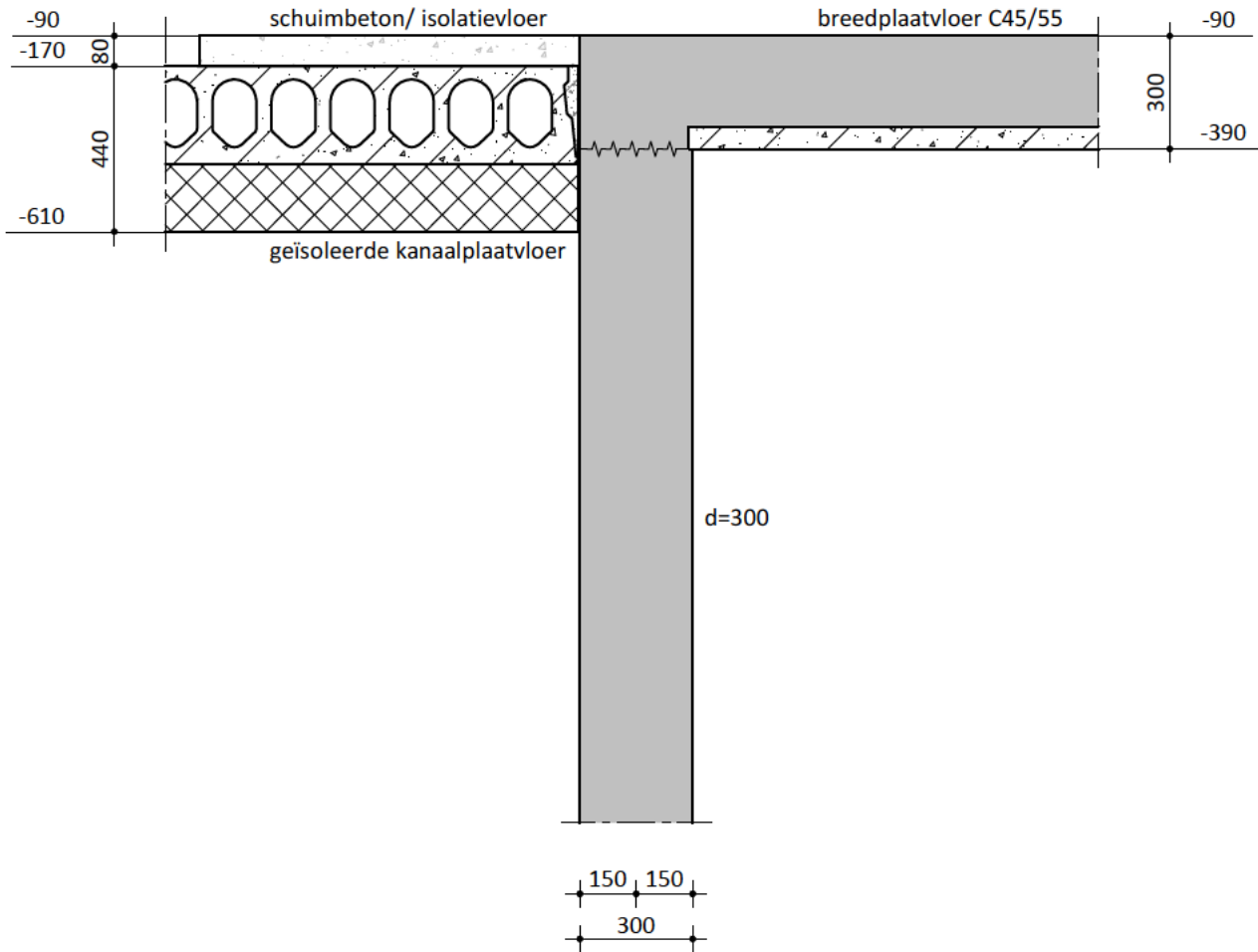

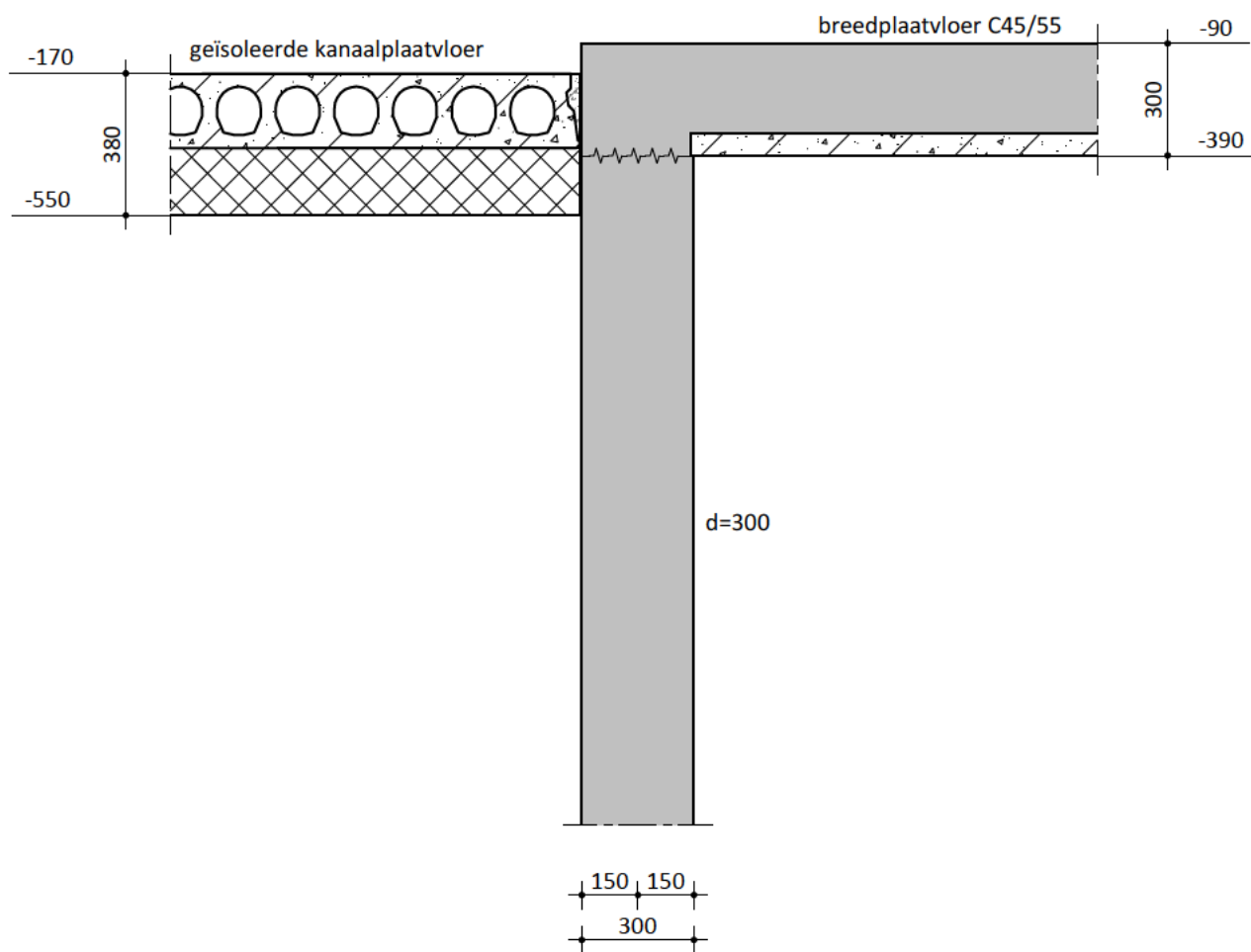

 <p>onderzoekt ontwerpt adviseert</p>	Project : Marktkwartier West te Amsterdam				
	Schaal : 1 : 20	Datum :	Onderdeel : Detail 0.26		
	Postbus 64, 7451 CH Holten T +31(0)548 85 33 33 E info@avecodebondt.nl I www.avecodebondt.nl	1.0	15-07-2022	Formaat : A4	Status : Definitief
		3.0	16-06-2023	Projectnummer:	Tekeningnummer:
4.0	15-12-2023	214570	D-0.26		

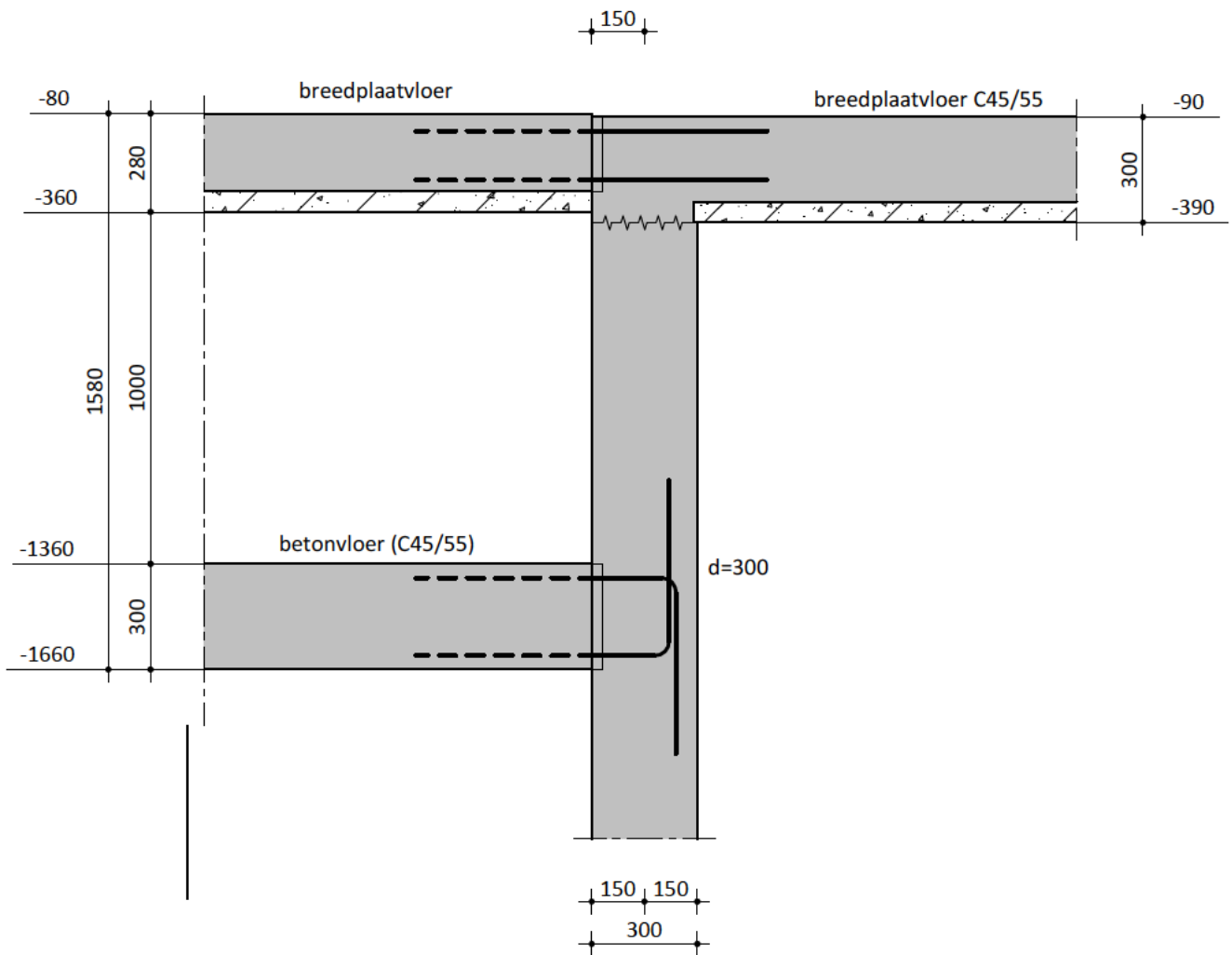

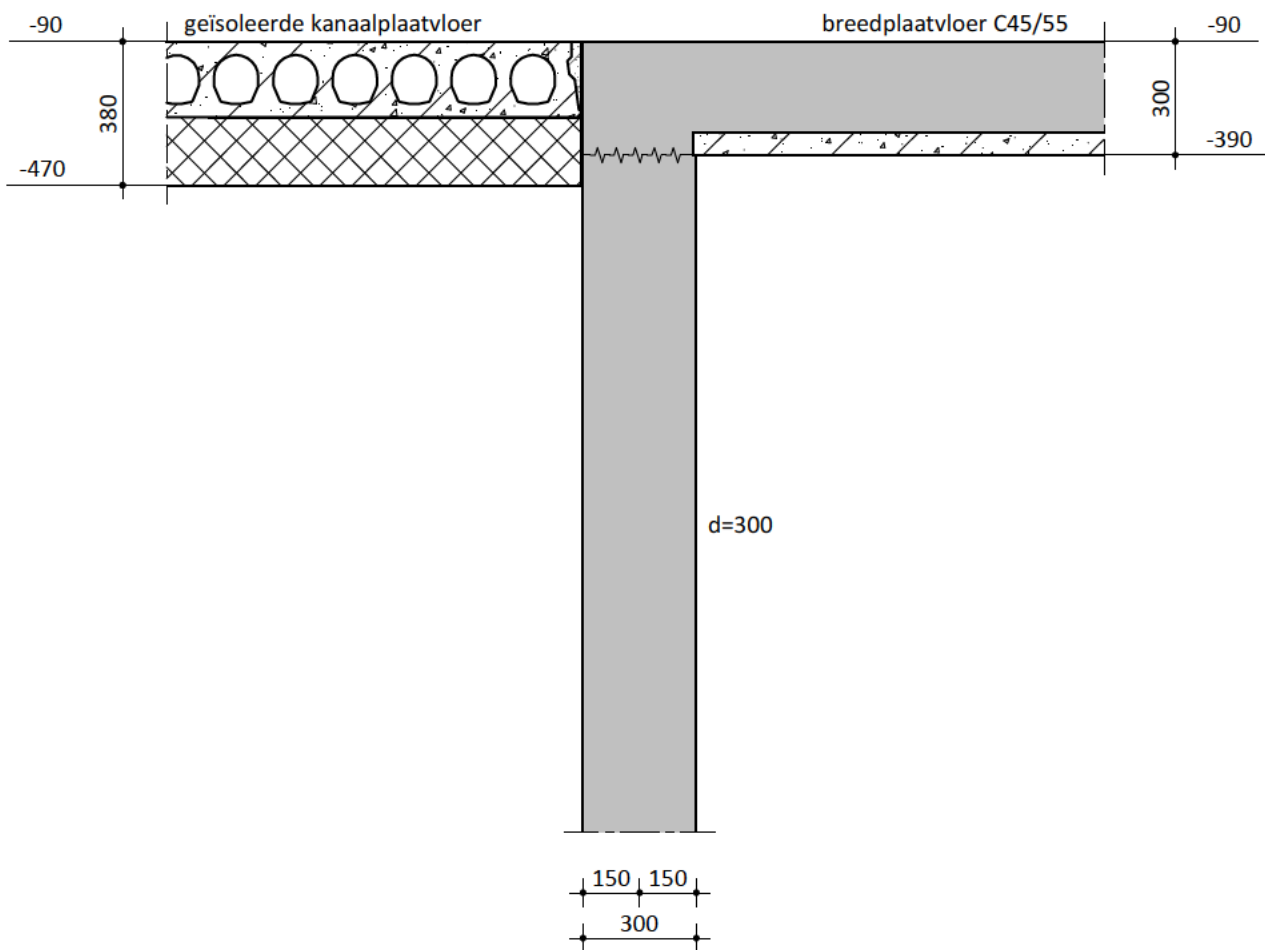

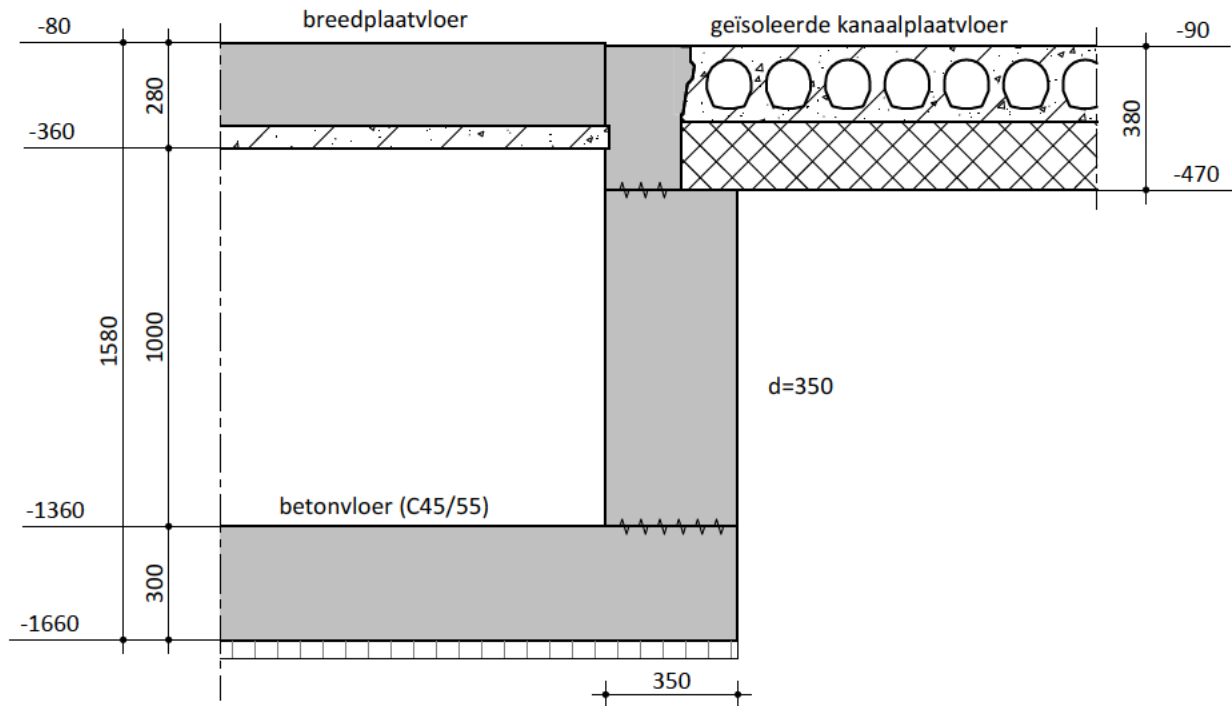

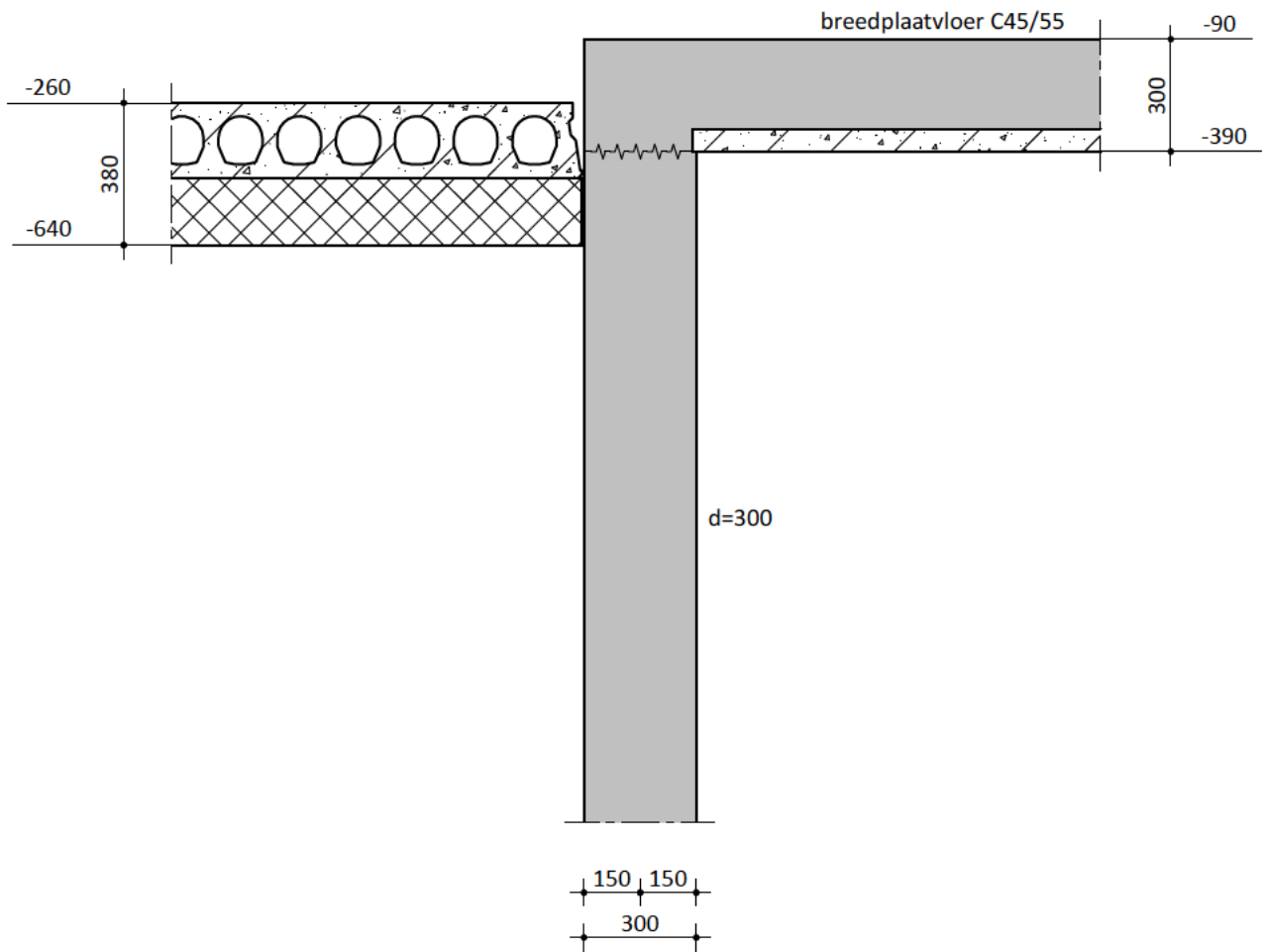

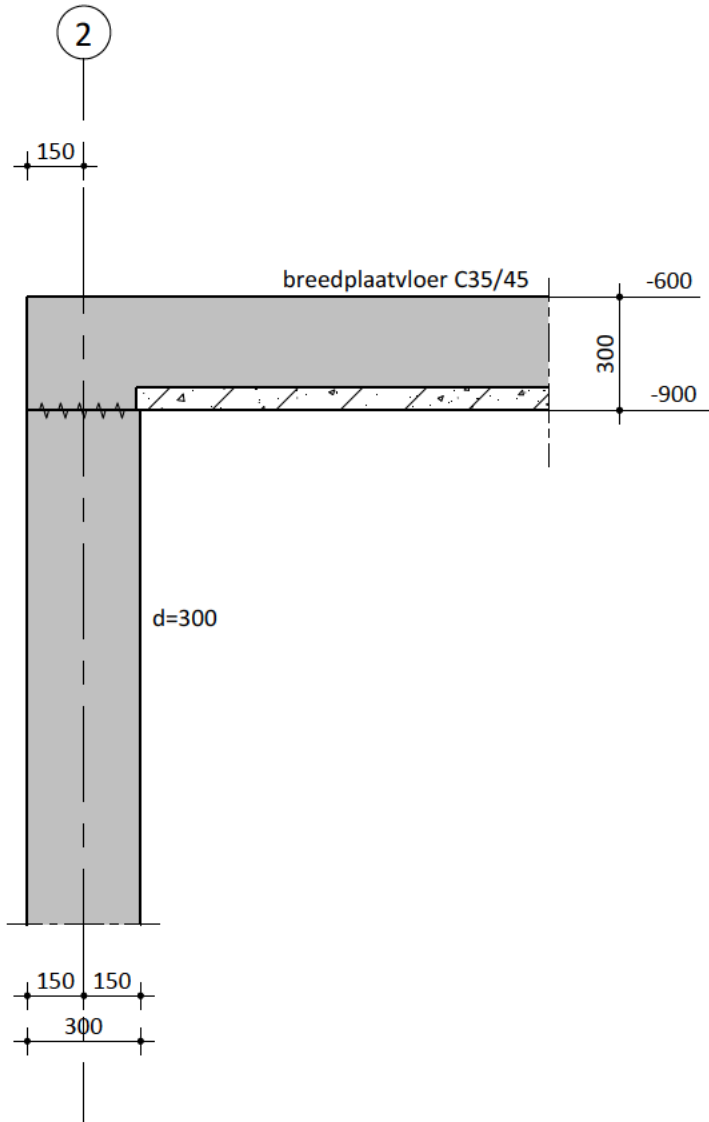

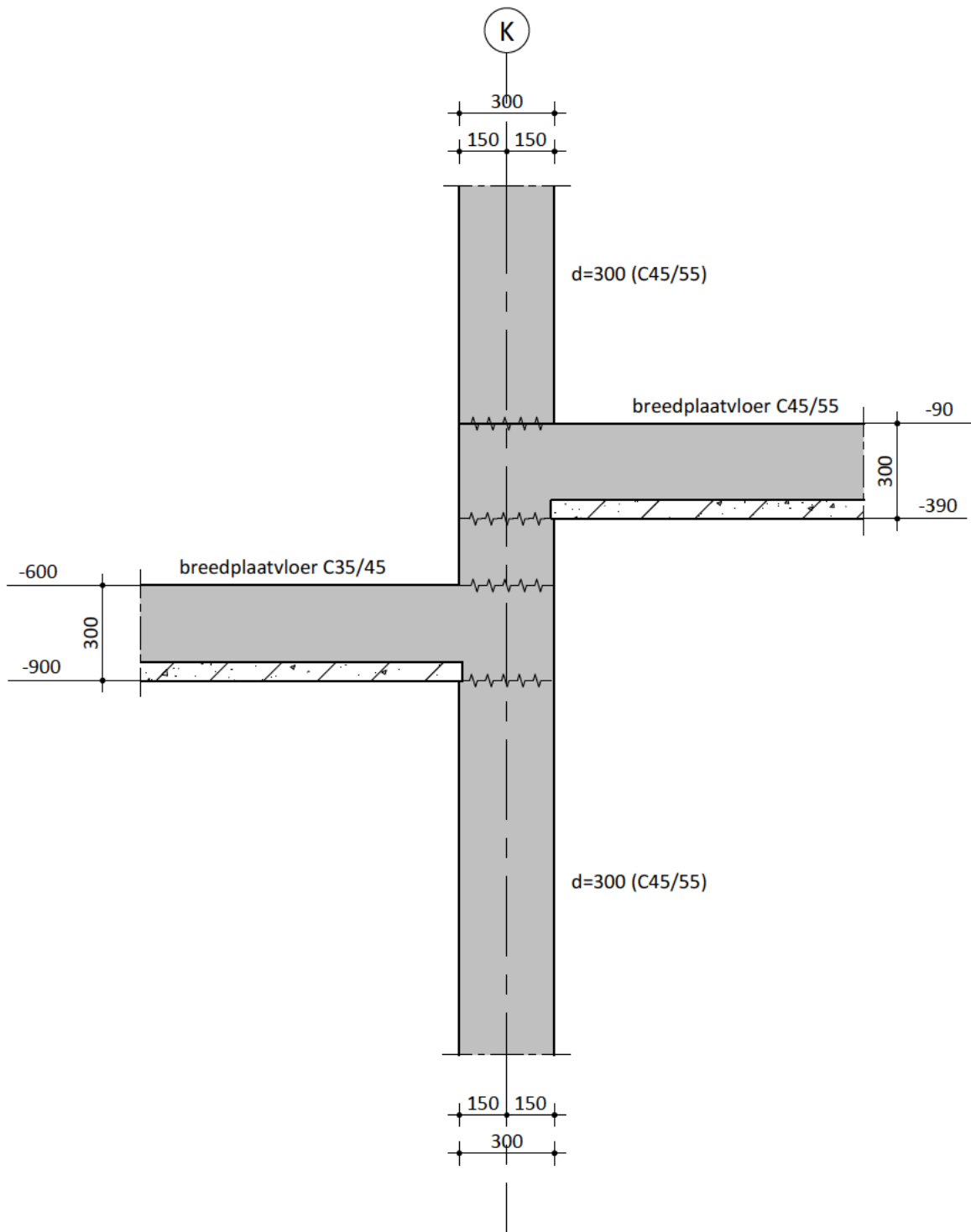



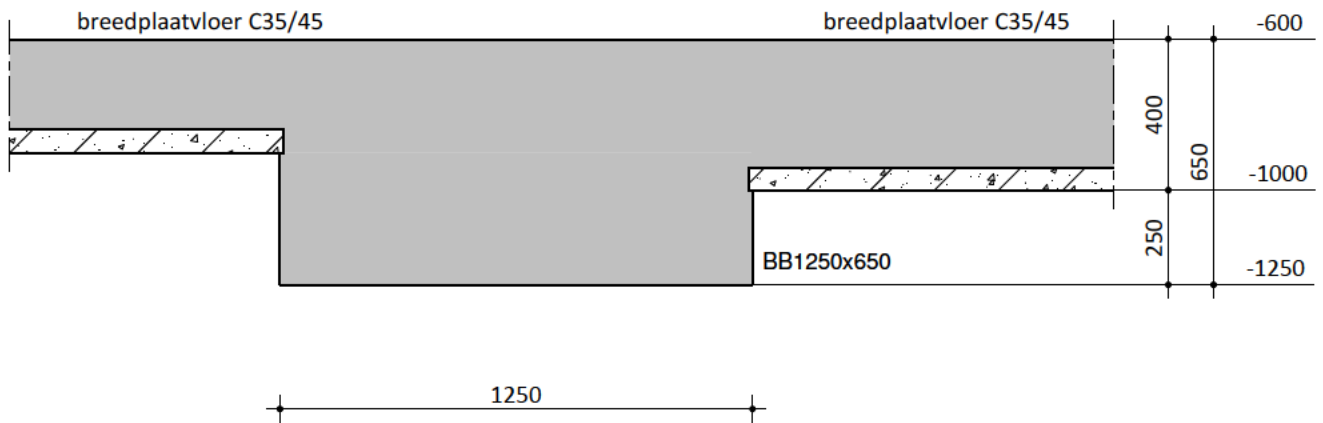

 <p>onderzoekt ontwerpt adviseert</p>	Project : Marktkwartier West te Amsterdam				
	Schaal : 1 : 20	Datum :	Onderdeel : Detail 0.32		
	Postbus 64, 7451 CH Holten T +31(0)548 85 33 33 E info@avecodebondt.nl I www.avecodebondt.nl	1.0	15-07-2022	Formaat : A4	Status : Definitief
		3.0	16-06-2023	Projectnummer:	Tekeningnummer:
4.0	15-12-2023	214570	D-0.32		



 <p>onderzoekt ontwerpt adviseert</p>	Project : Marktkwartier West te Amsterdam				
	Schaal : 1 : 20		Datum :	Onderdeel : Detail 0.33	
	Postbus 64, 7451 CH Holten T +31(0)548 85 33 33 E info@avecodebondt.nl I www.avecodebondt.nl	1.0	15-07-2022	Formaat : A4	Status : Definitief
		3.0	16-06-2023	Projectnummer:	Tekeningnummer:
	4.0	15-12-2023	214570	D-0.33	

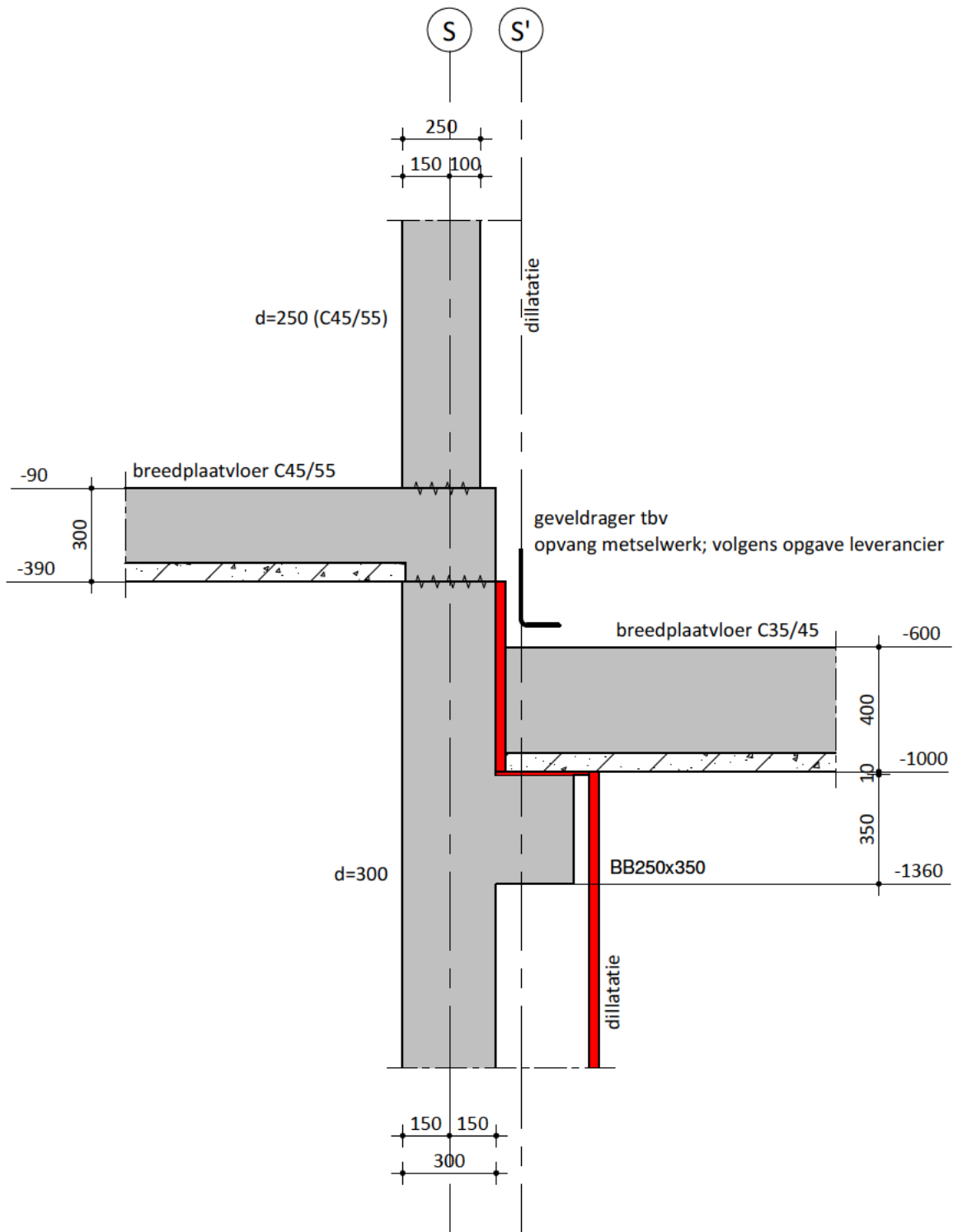

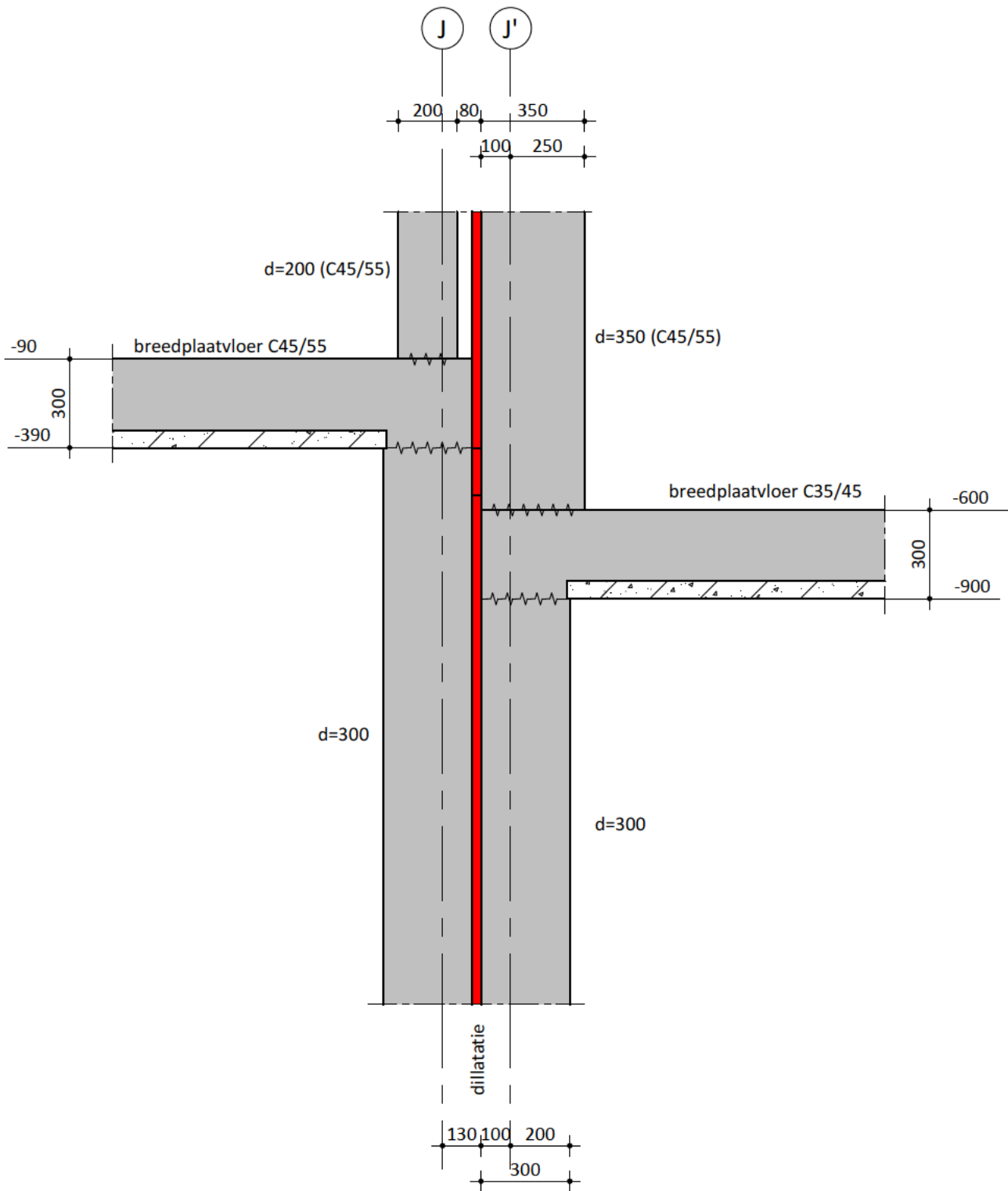

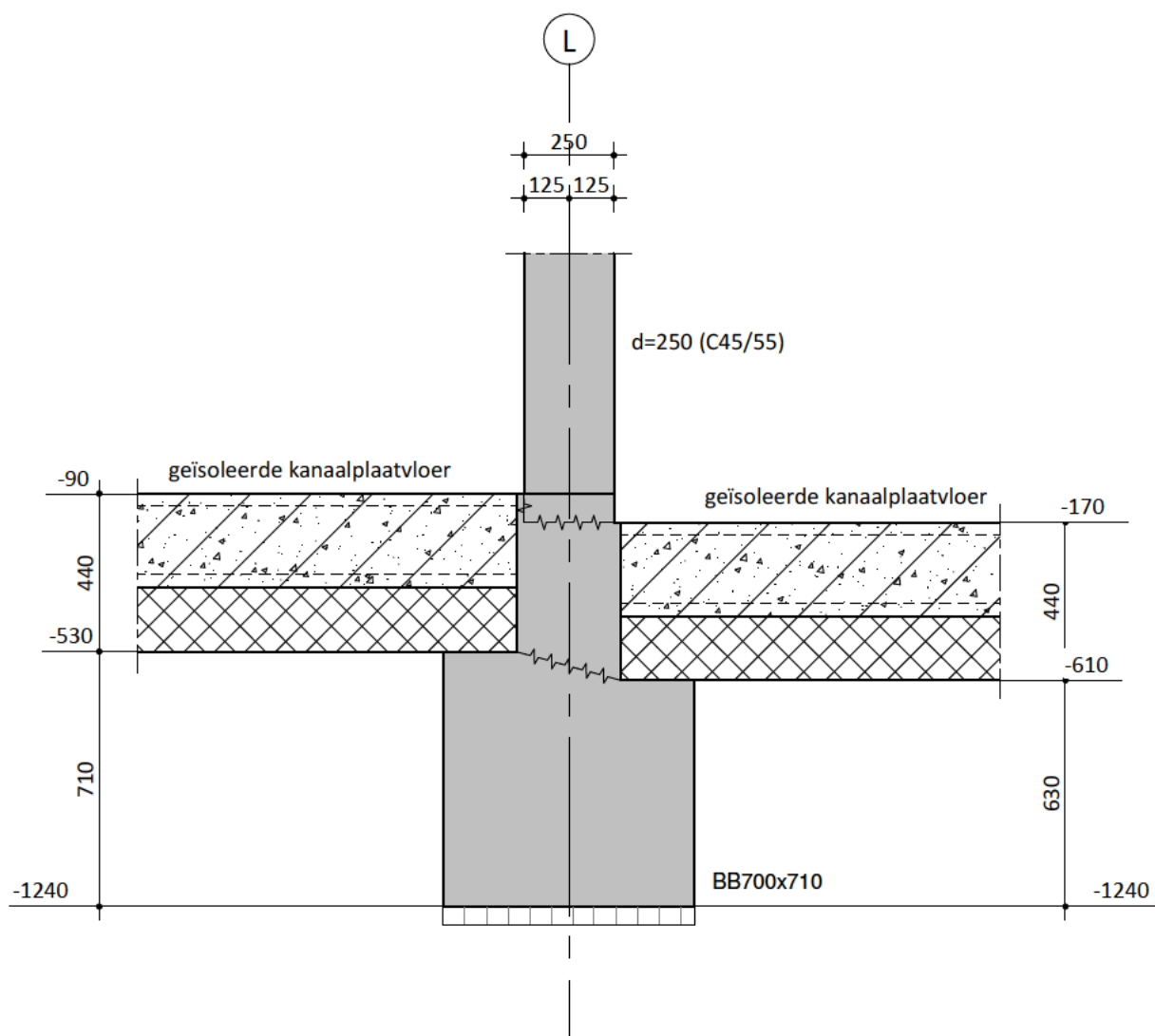

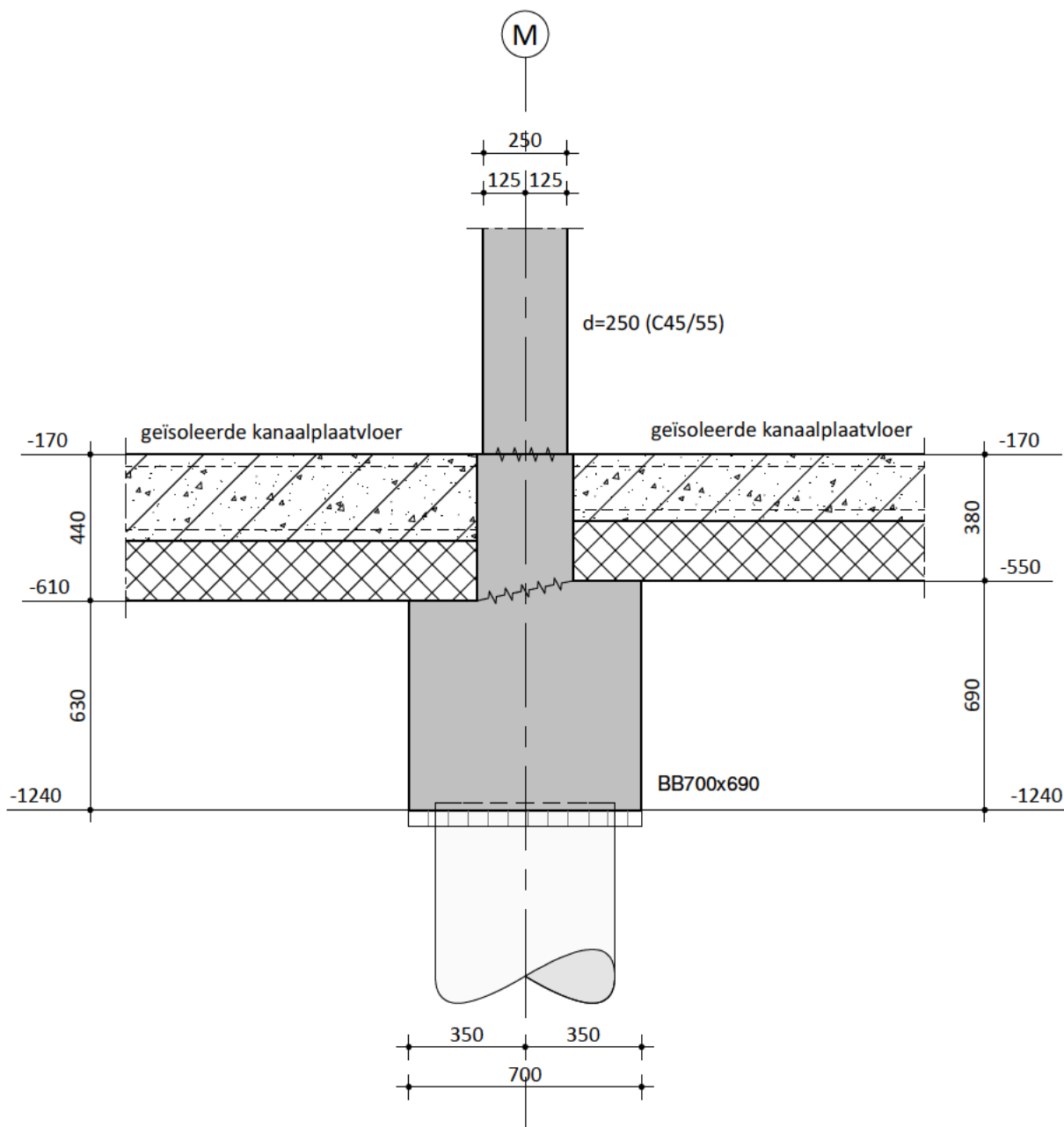

 <p>onderzoekt ontwerpt adviseert</p>	Project : Marktkwartier West te Amsterdam			
	Schaal : 1 : 20	Datum :	Onderdeel : Detail 0.36	
	Postbus 64, 7451 CH Holten T +31(0)548 85 33 33 E info@avecodebondt.nl I www.avecodebondt.nl	1.0	15-07-2022	Formaat : A4
		3.0	16-06-2023	Projectnummer: 214570
4.0	15-12-2023	Status : Definitief	Tekeningnummer: D-0.36	

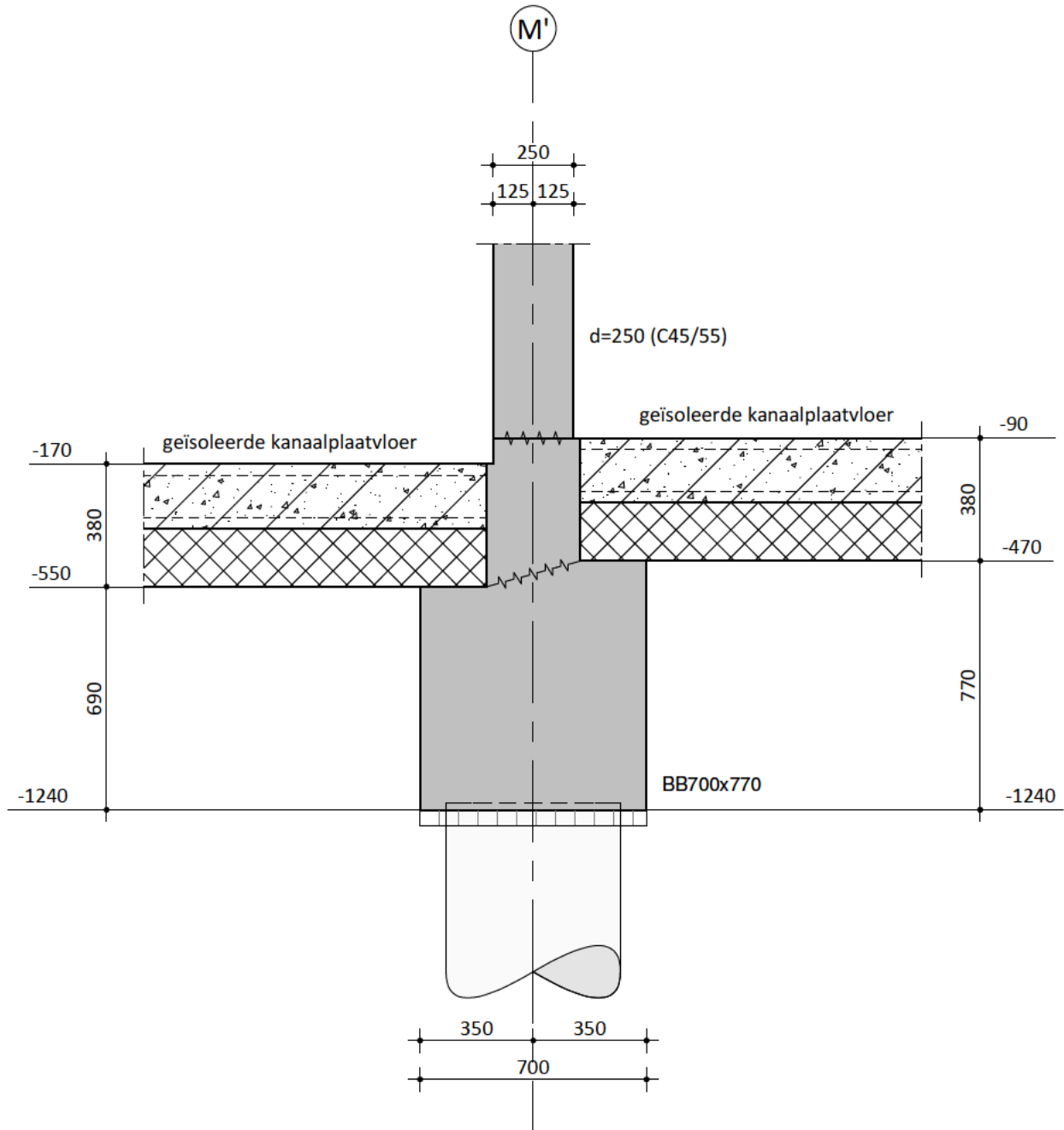

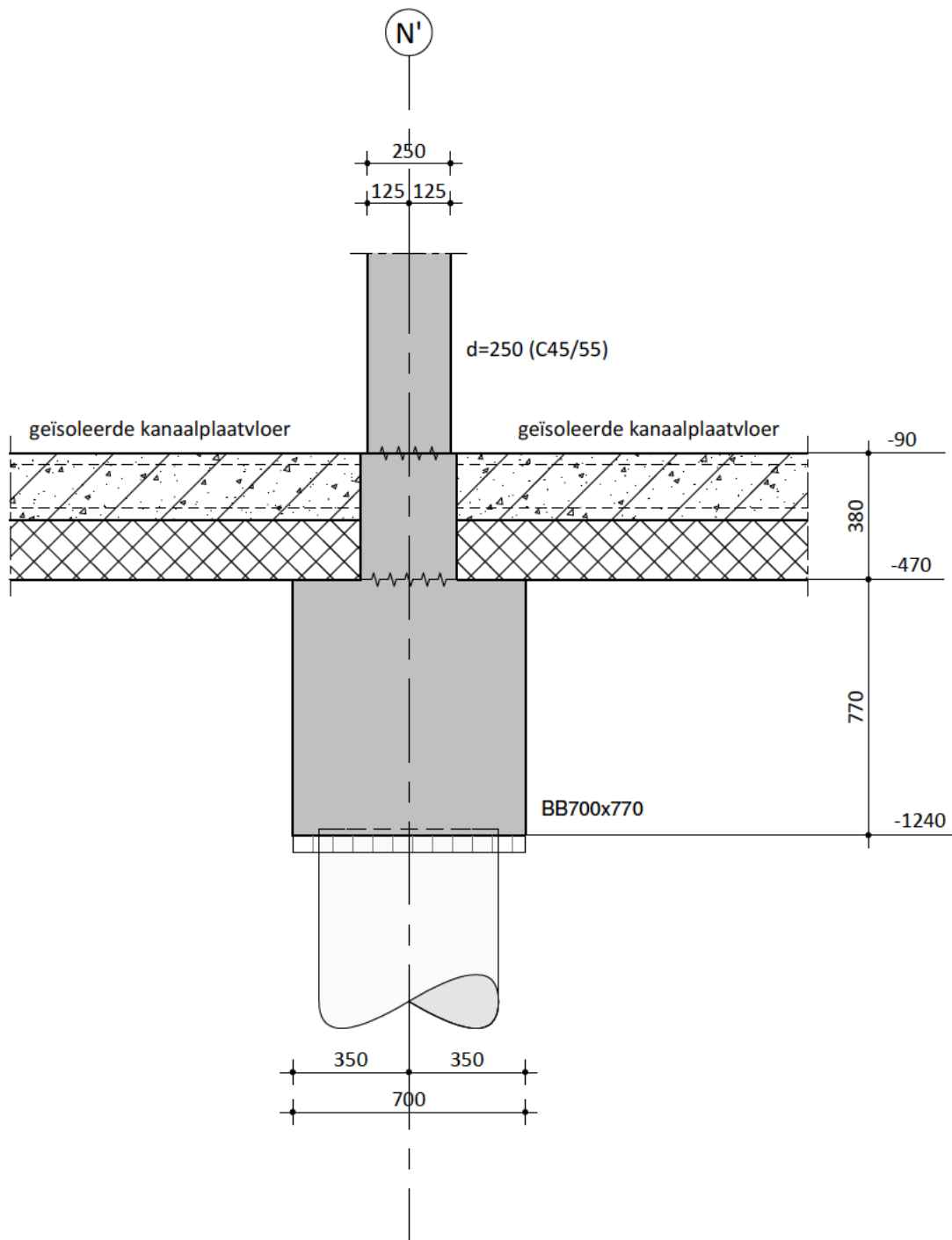



 <p>onderzoekt ontwerpt adviseert</p>	Project : Marktkwartier West te Amsterdam			
	Schaal : 1 : 20	Datum :	Onderdeel : Detail 0.39	
	Postbus 64, 7451 CH Holten T +31(0)548 85 33 33 E info@avecodebondt.nl I www.avecodebondt.nl	1.0	15-07-2022	Formaat : A4
		3.0	16-06-2023	Projectnummer: 214570
4.0	15-12-2023	Status : Definitief	Tekeningnummer: D-0.39	

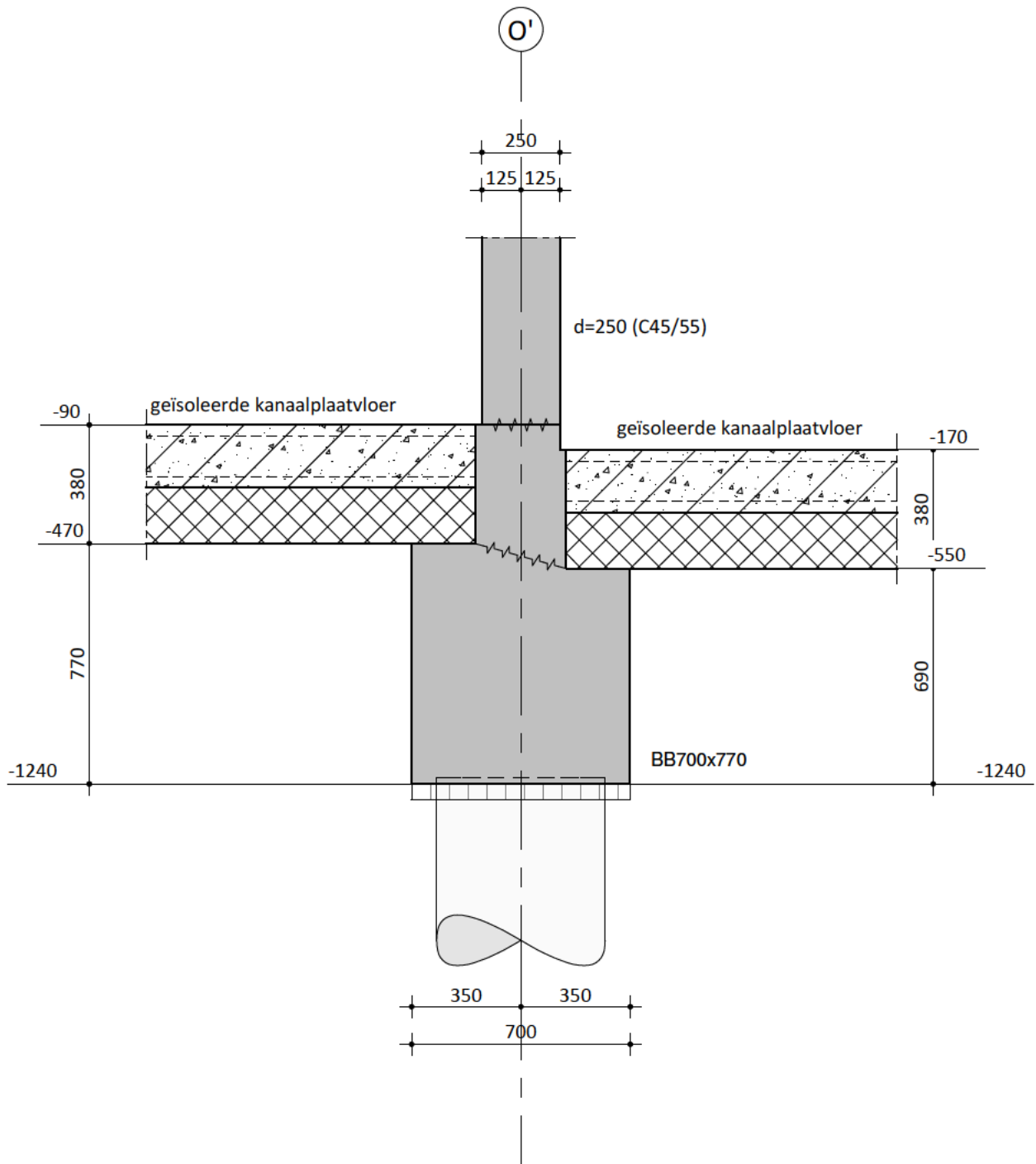

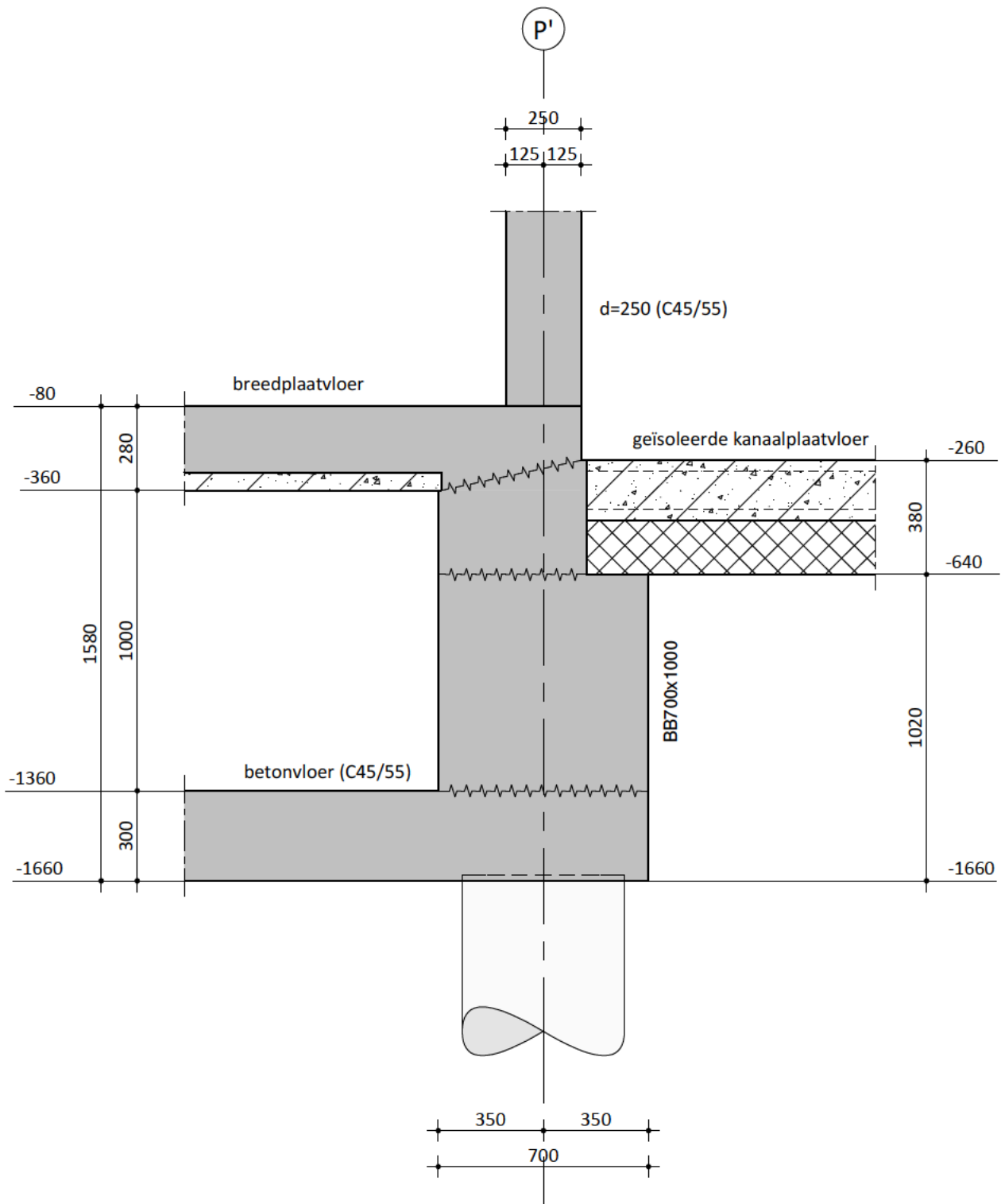

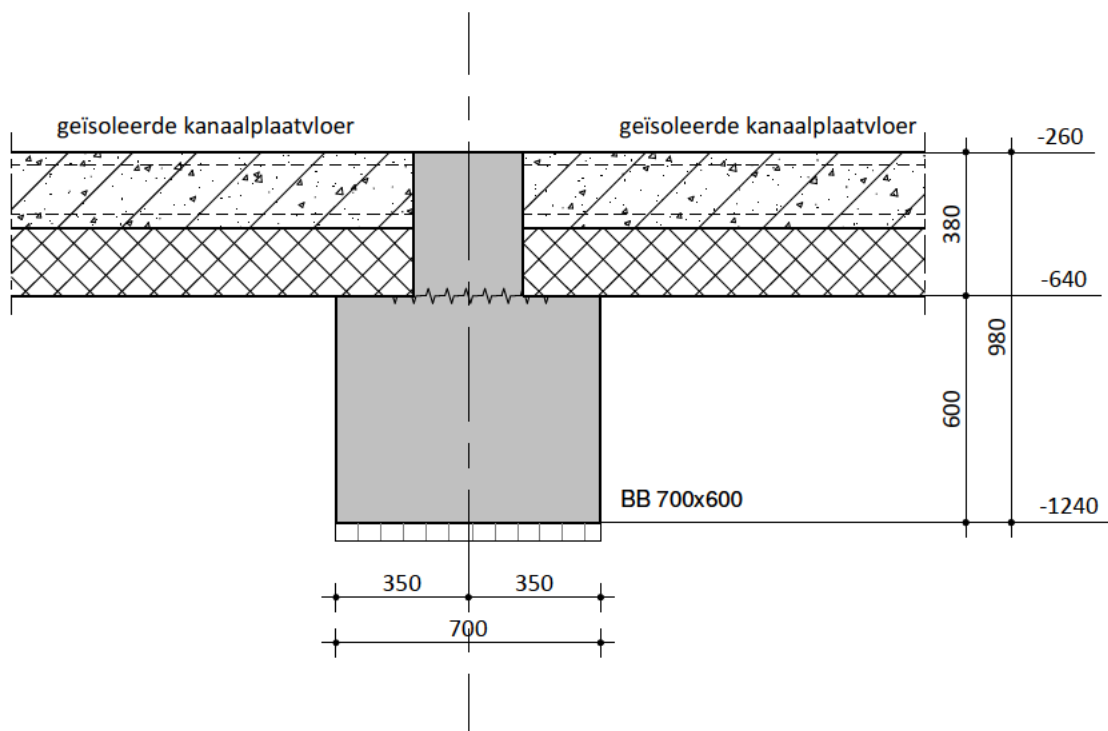

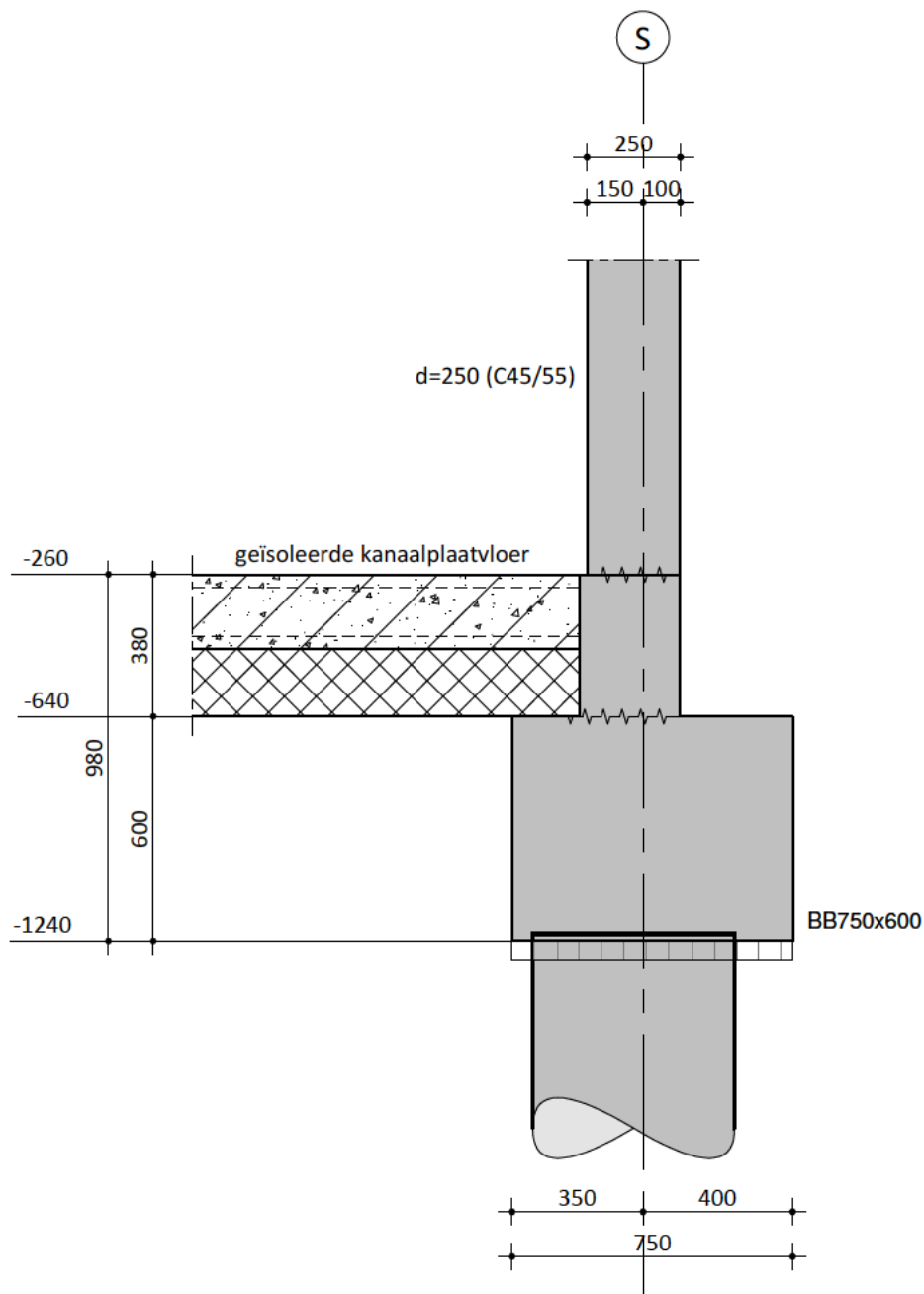

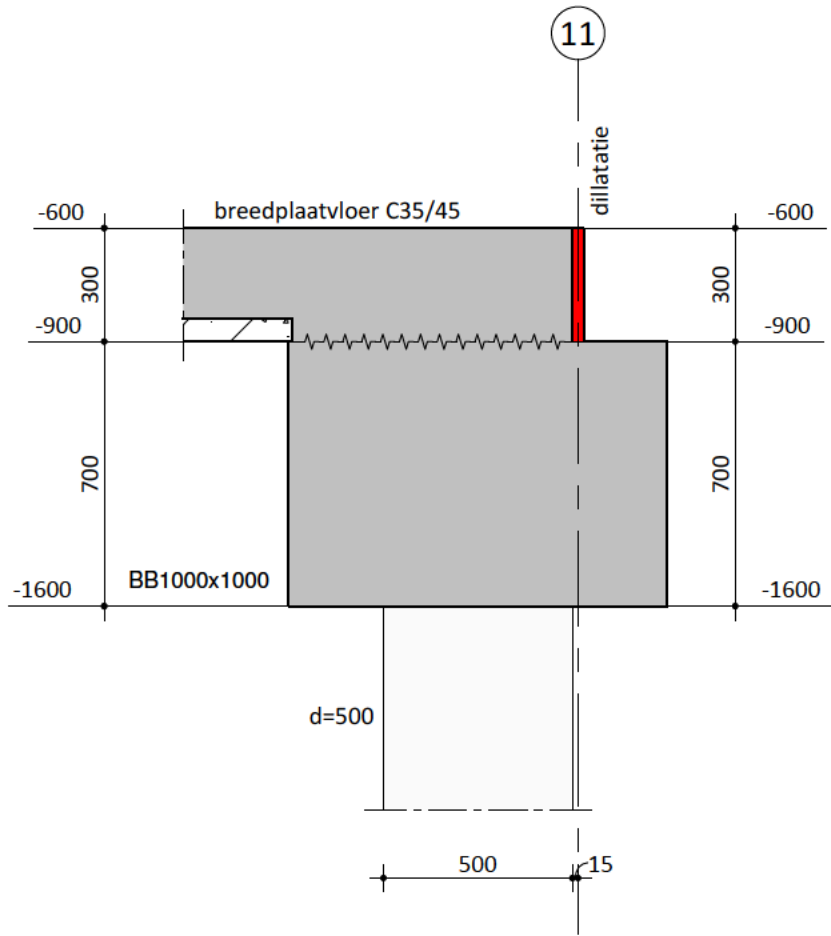

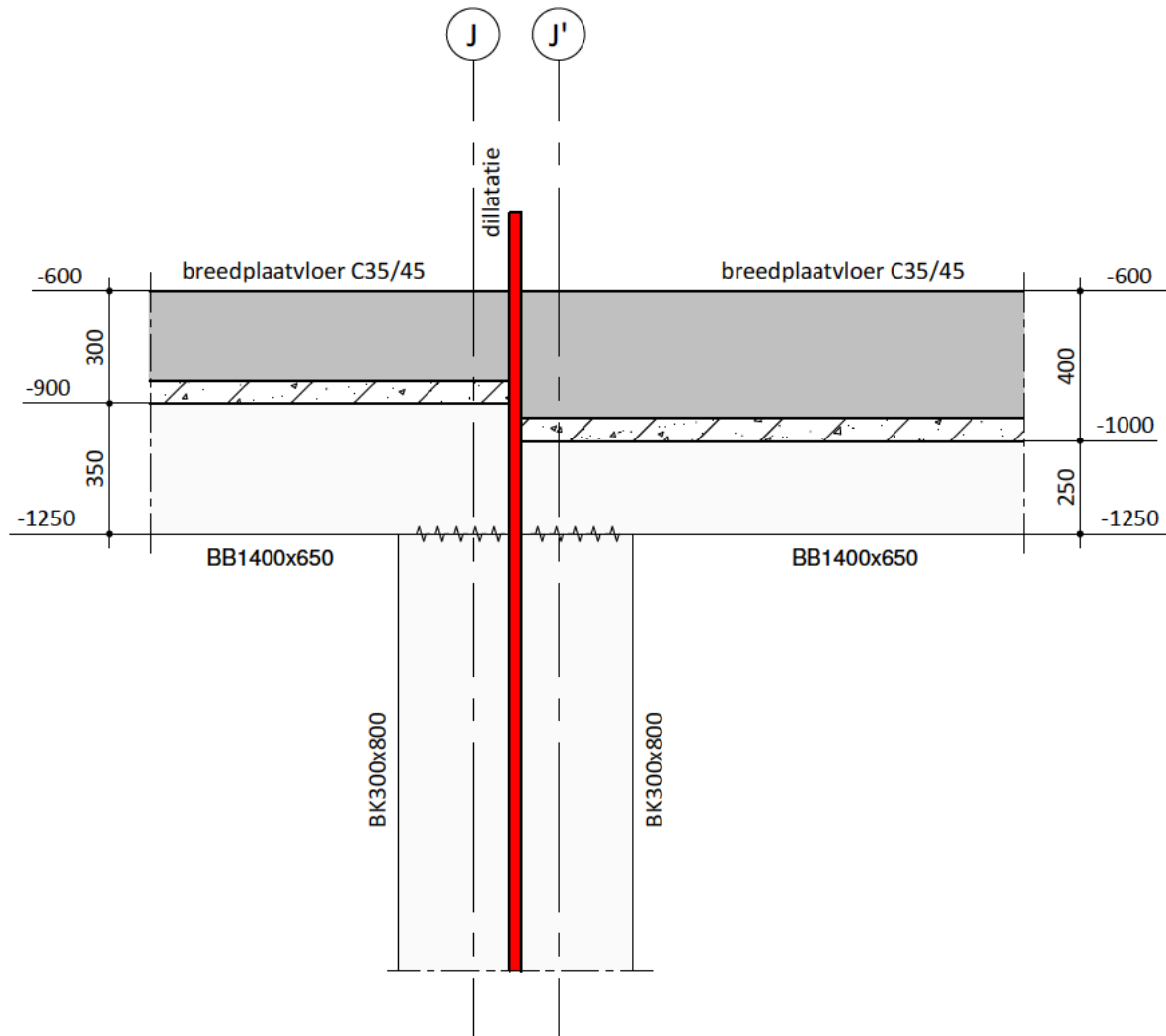

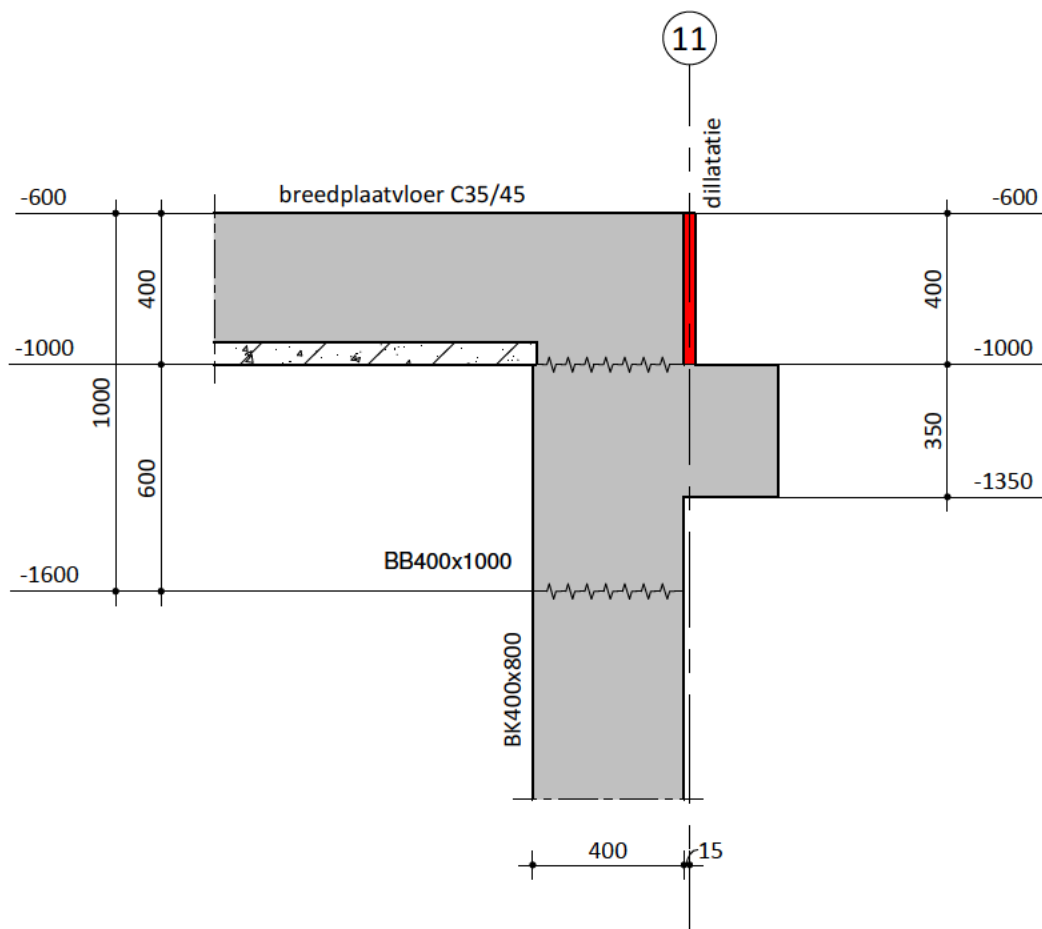

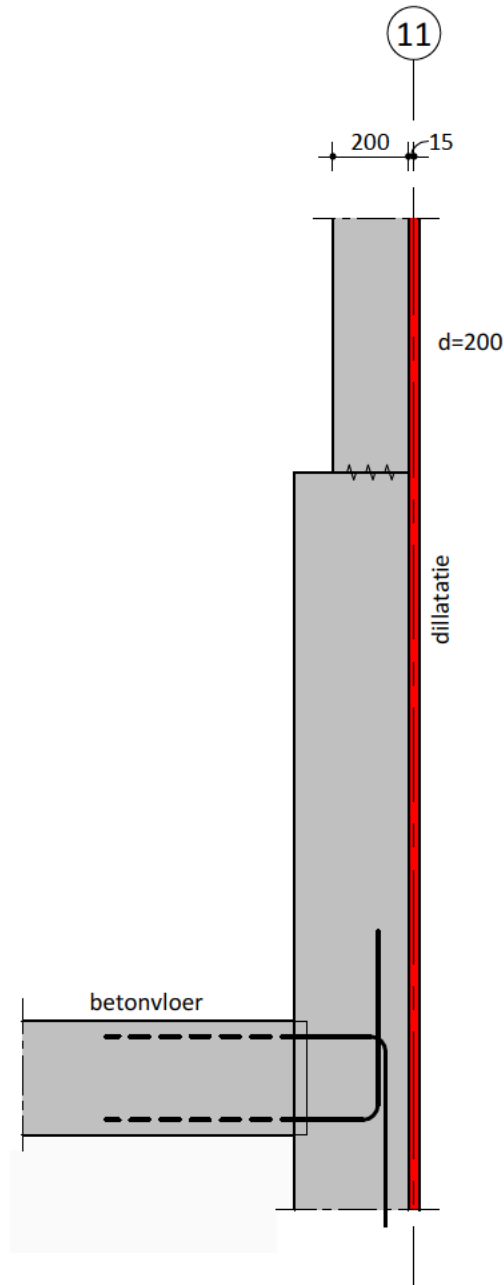

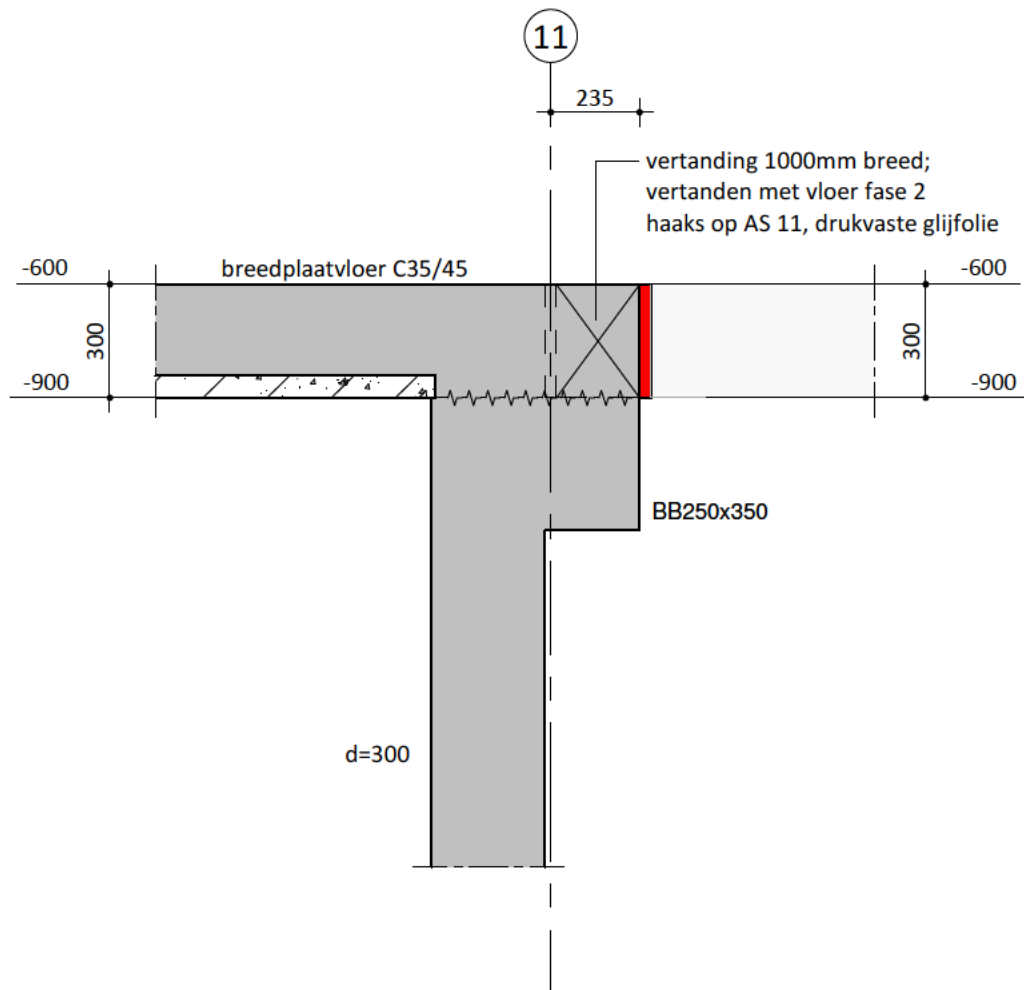

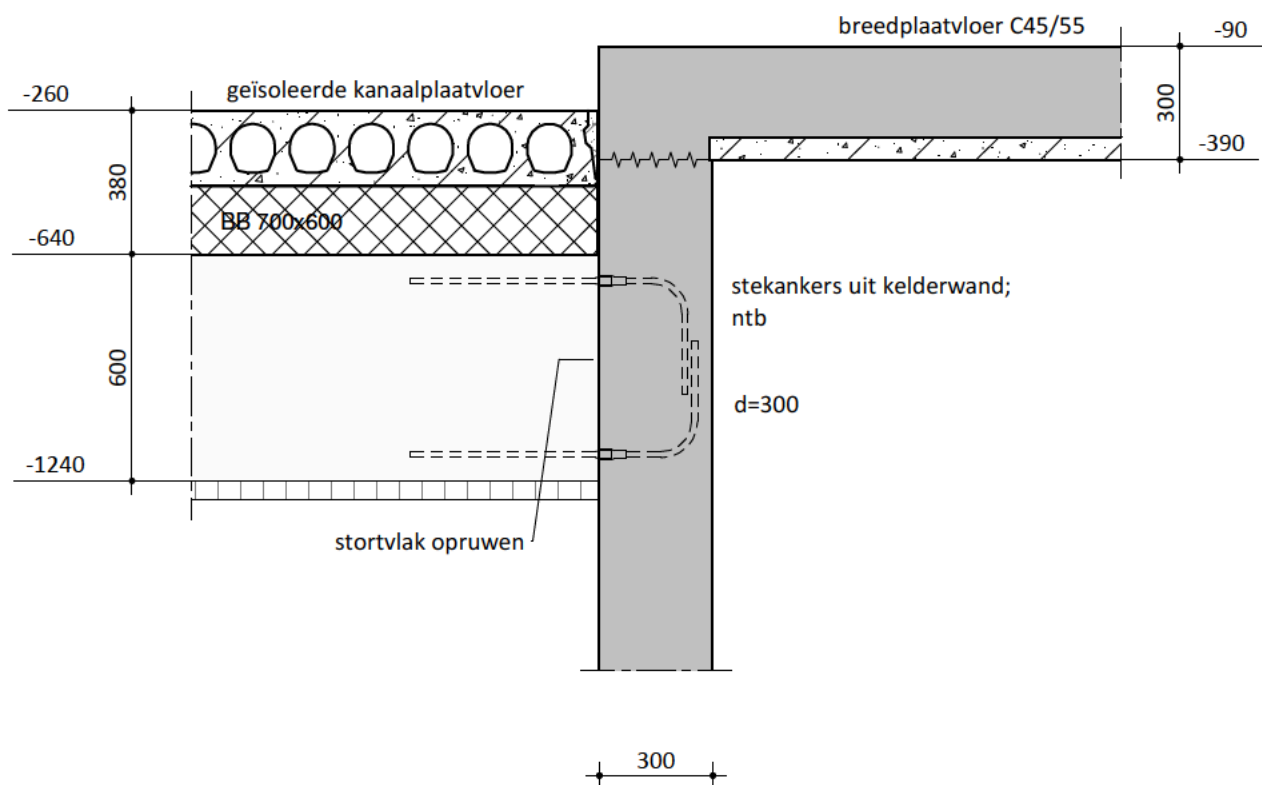





Principe balkaansluiting/ kelderwand

1 : 20

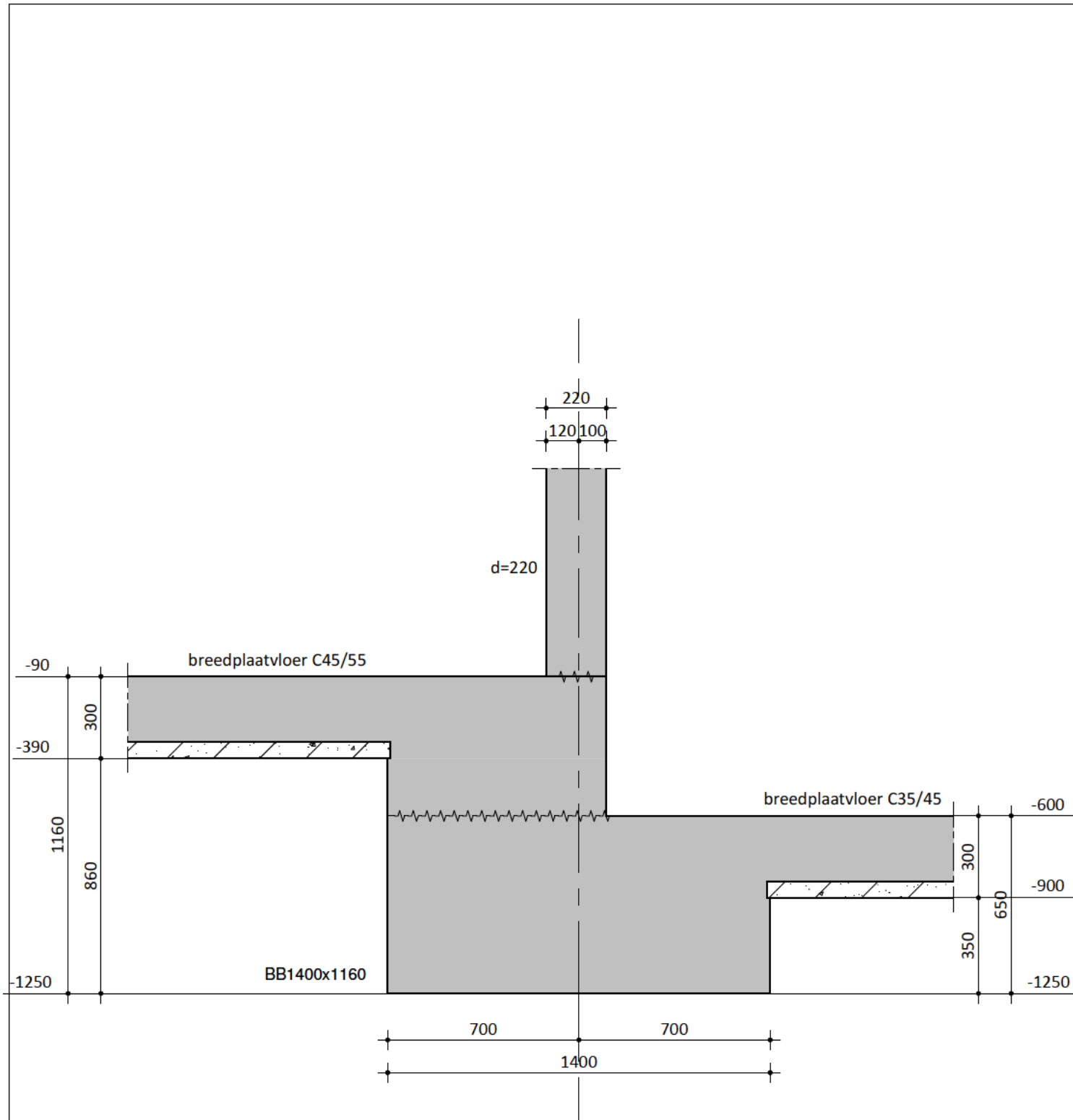
 <p>onderzoekt ontwerpt adviseert</p>	Project : Marktkwartier West te Amsterdam			
	Schaal : 1 : 20	Datum :	Onderdeel : Detail 0.49	
	Postbus 64, 7451 CH Holten T +31(0)548 85 33 33 E info@avecodebondt.nl I www.avecodebondt.nl	1.0	15-07-2022	Formaat : A4
		3.0	16-06-2023	Projectnummer:
4.0	15-12-2023	214570	Status : Definitief	
			Tekeningnummer: D-0.49	



 <p>onderzoekt ontwerpt adviseert</p>	Project : Marktkwartier West te Amsterdam			
	Schaal : 1 : 20	Datum :	Onderdeel : Detail 0.50	
	Postbus 64, 7451 CH Holten T +31(0)548 85 33 33 E info@avecodebondt.nl I www.avecodebondt.nl	1.0 06-03-2023	Formaat : A4	Status : Definitief
		2.0 16-06-2023	Projectnummer:	Tekeningnummer:
3.0 15-12-2023	214570	D-0.50		

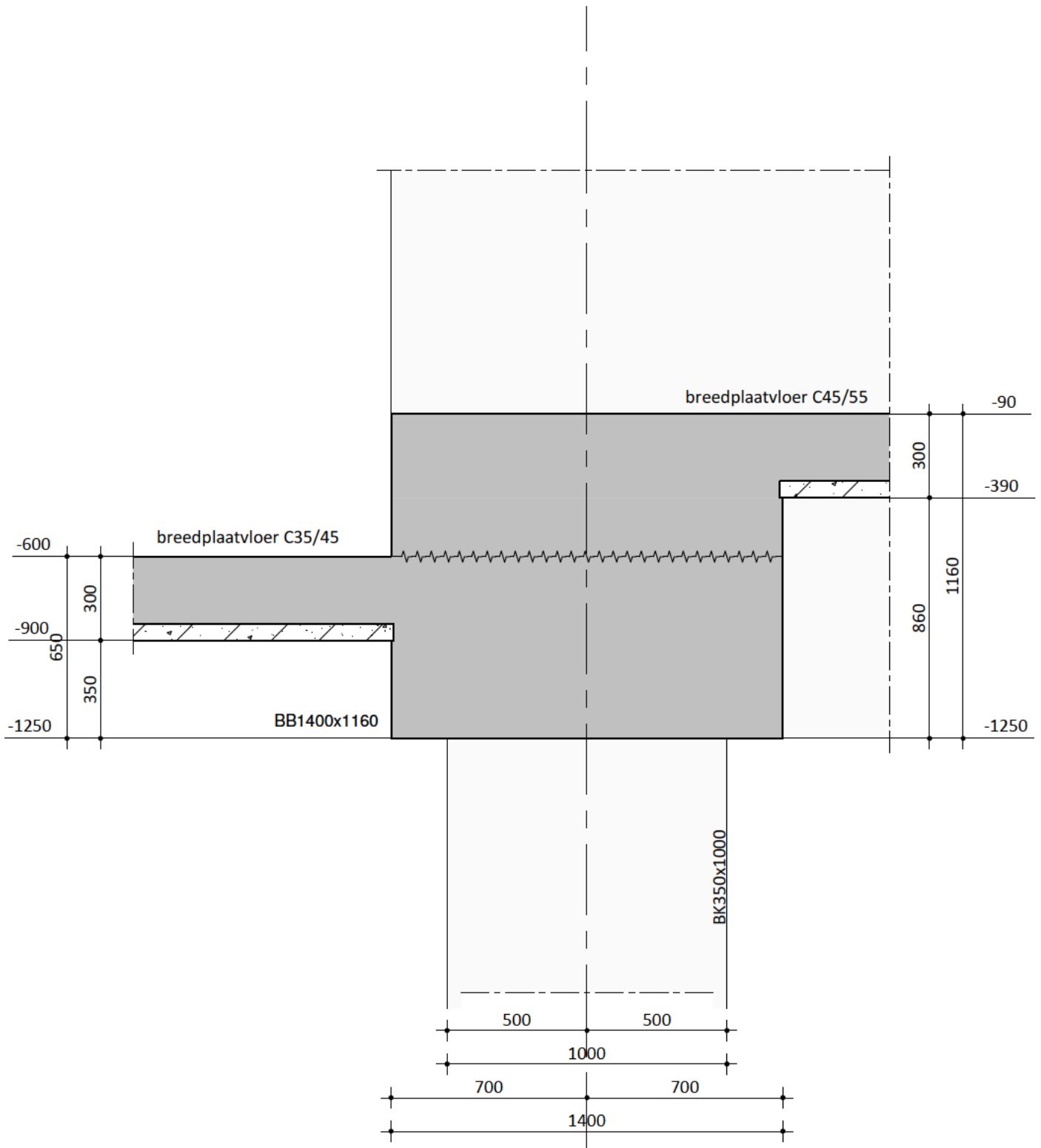

 <p>onderzoekt ontwerpt adviseert</p>	Project : Marktkwartier West te Amsterdam			
	Schaal : 1 : 20	Datum :	Onderdeel : Detail 0.51	
	Postbus 64, 7451 CH Holten T +31(0)548 85 33 33 E info@avecodebondt.nl I www.avecodebondt.nl	1.0	06-03-2023	Formaat : A4
		2.0	16-06-2023	Projectnummer:
	3.0	15-12-2023	214570	
			Status : Definitief	
			Tekeningnummer:	
			D-0.51	

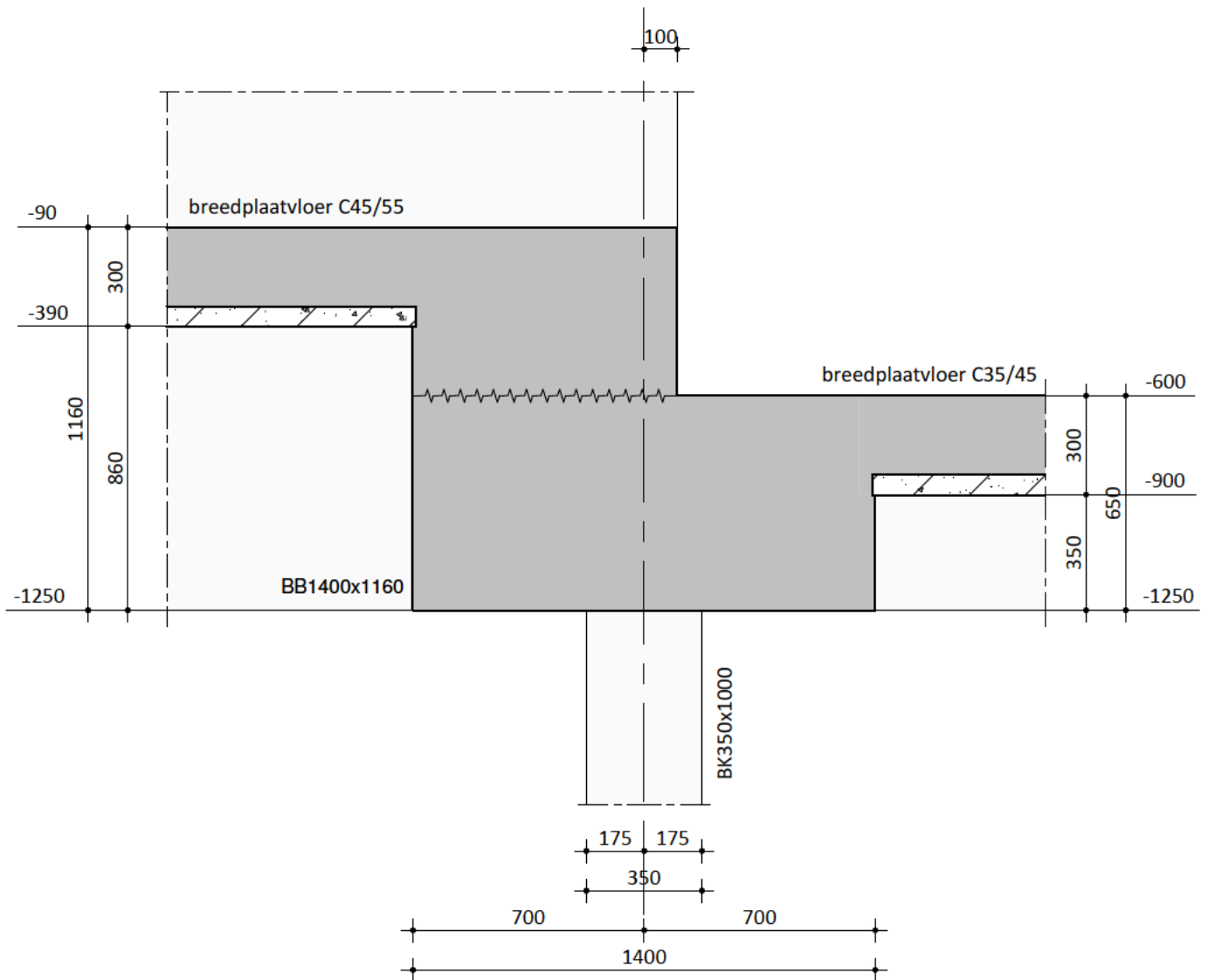

 <p>onderzoekt ontwerpt adviseert</p>	Project : Marktkwartier West te Amsterdam			
	Schaal : 1 : 20	Datum :	Onderdeel : Detail 0.52	
	Postbus 64, 7451 CH Holten T +31(0)548 85 33 33 E info@avecodebondt.nl I www.avecodebondt.nl	1.0	06-03-2023	Formaat : A4
		2.0	16-06-2023	Projectnummer:
3.0	15-12-2023	214570	Status : Definitief	
			Tekeningnummer: D-0.52	

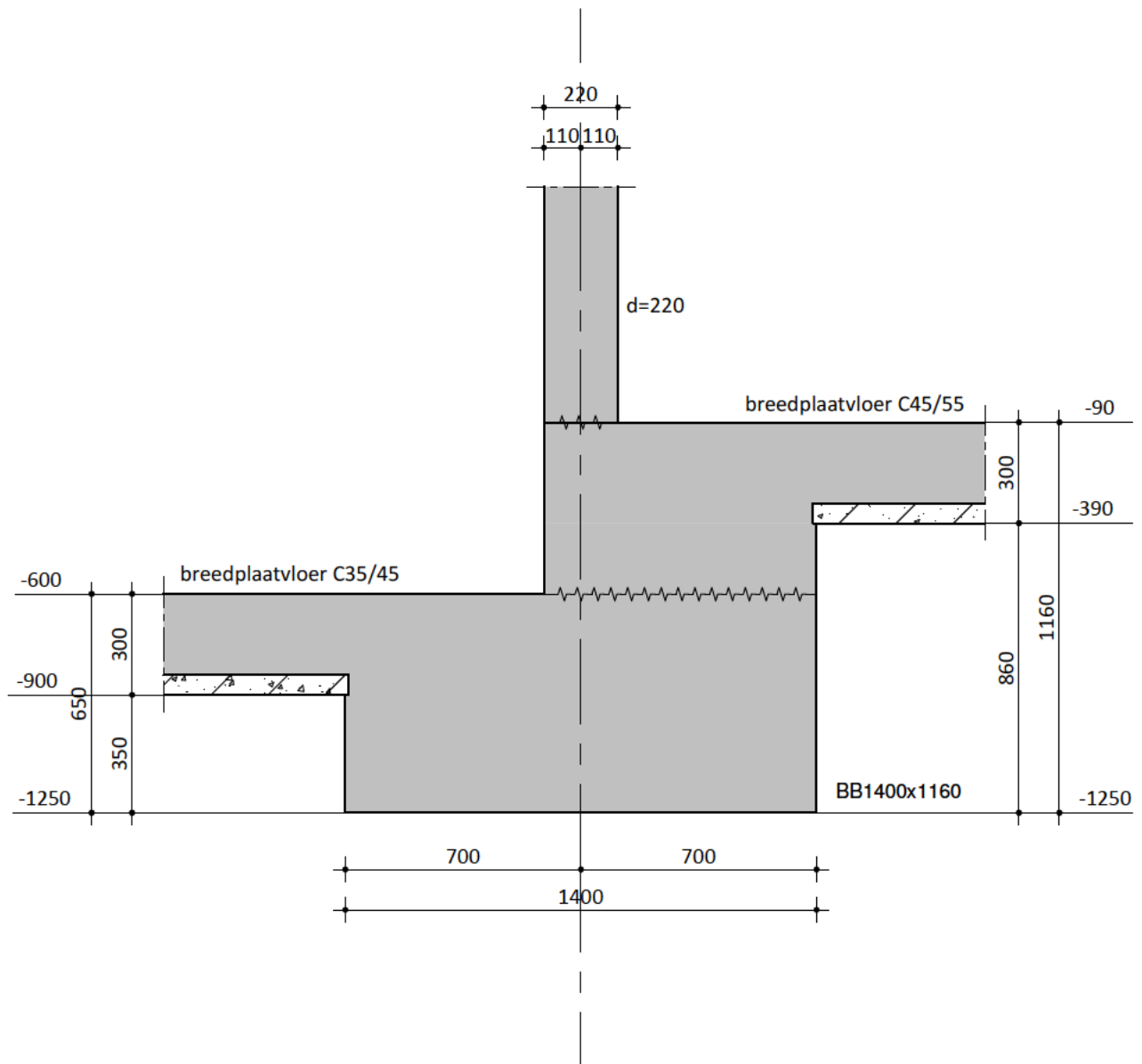

 <p>onderzoekt ontwerpt adviseert</p>	Project : Marktkwartier West te Amsterdam			
	Schaal : 1 : 20	Datum :	Onderdeel : Detail 0.53	
	Postbus 64, 7451 CH Holten T +31(0)548 85 33 33 E info@avecodebondt.nl I www.avecodebondt.nl	1.0	06-03-2023	Formaat : A4
		2.0	16-06-2023	Projectnummer:
	3.0	15-12-2023	214570	
			Status : Definitief	
			Tekeningnummer:	
			D-0.53	

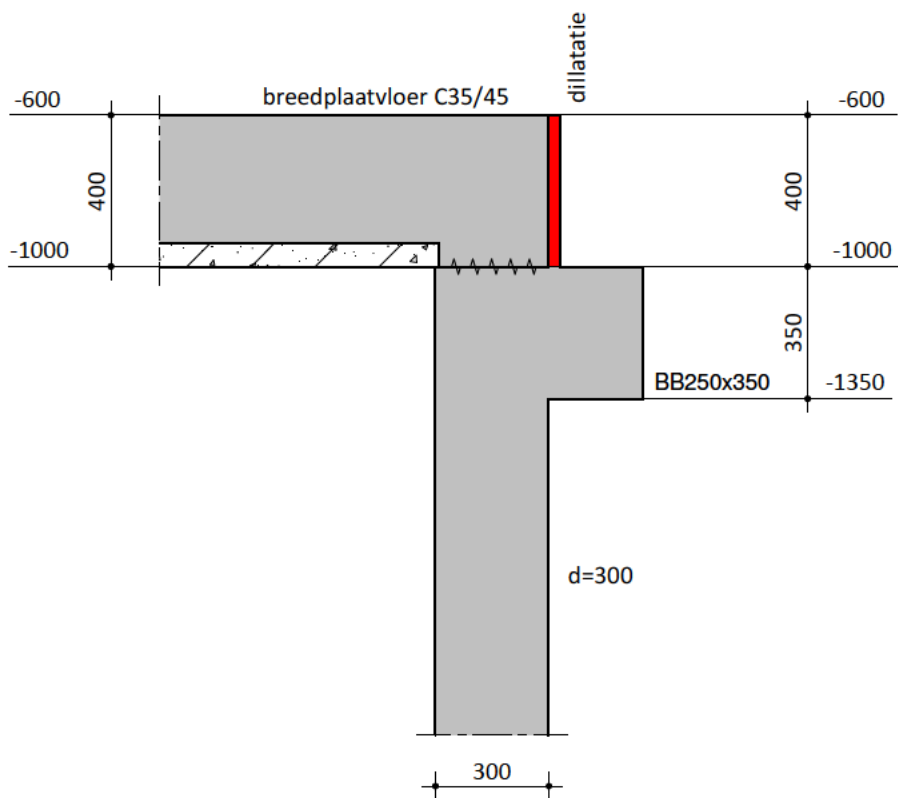

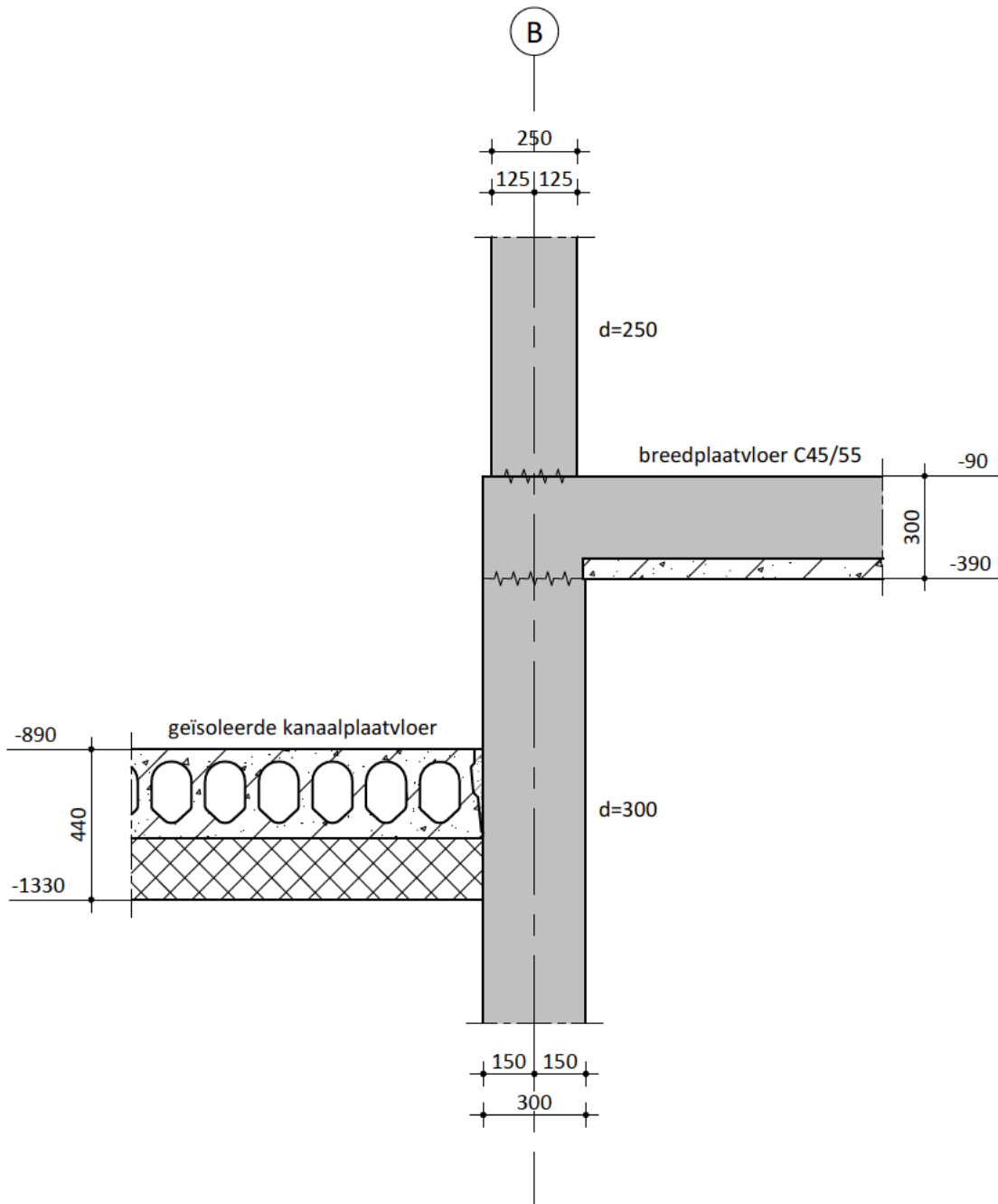

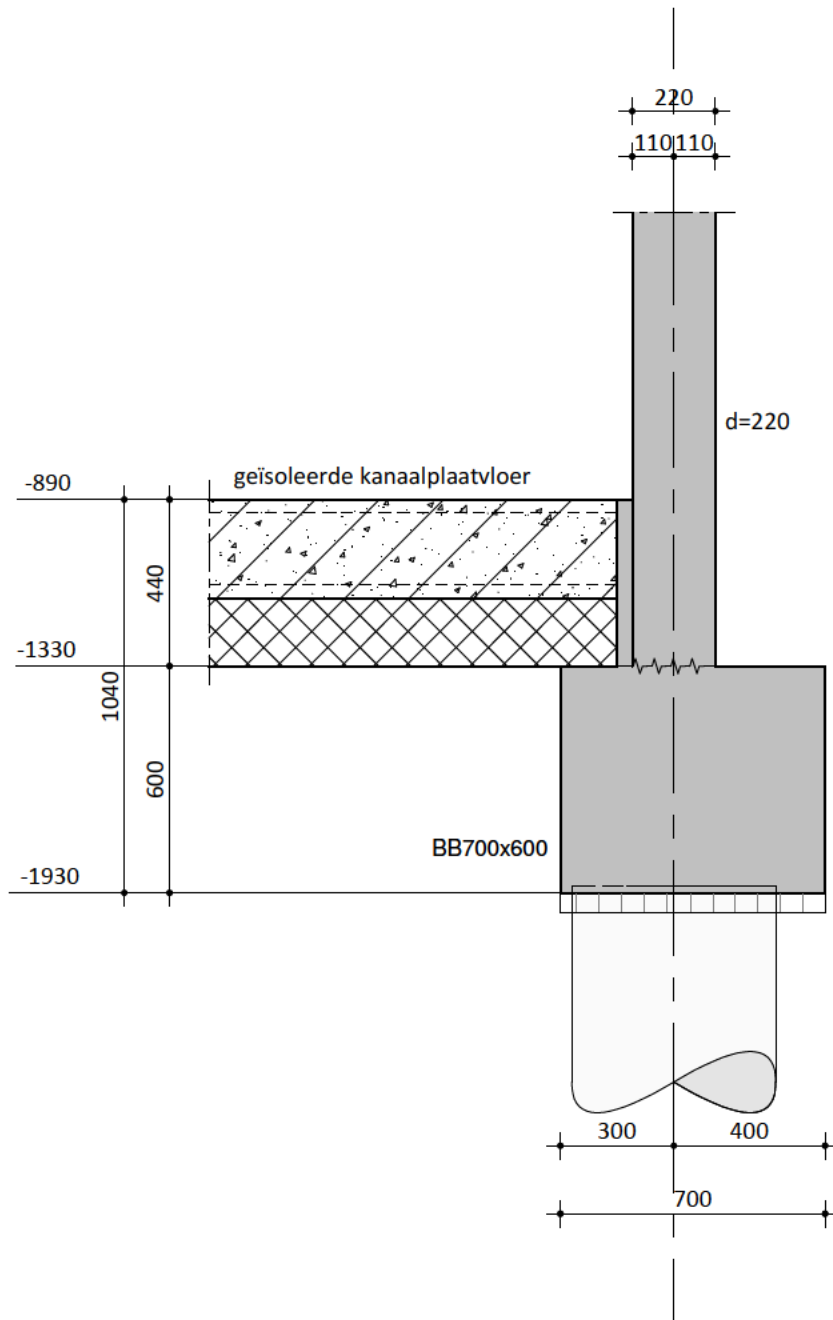

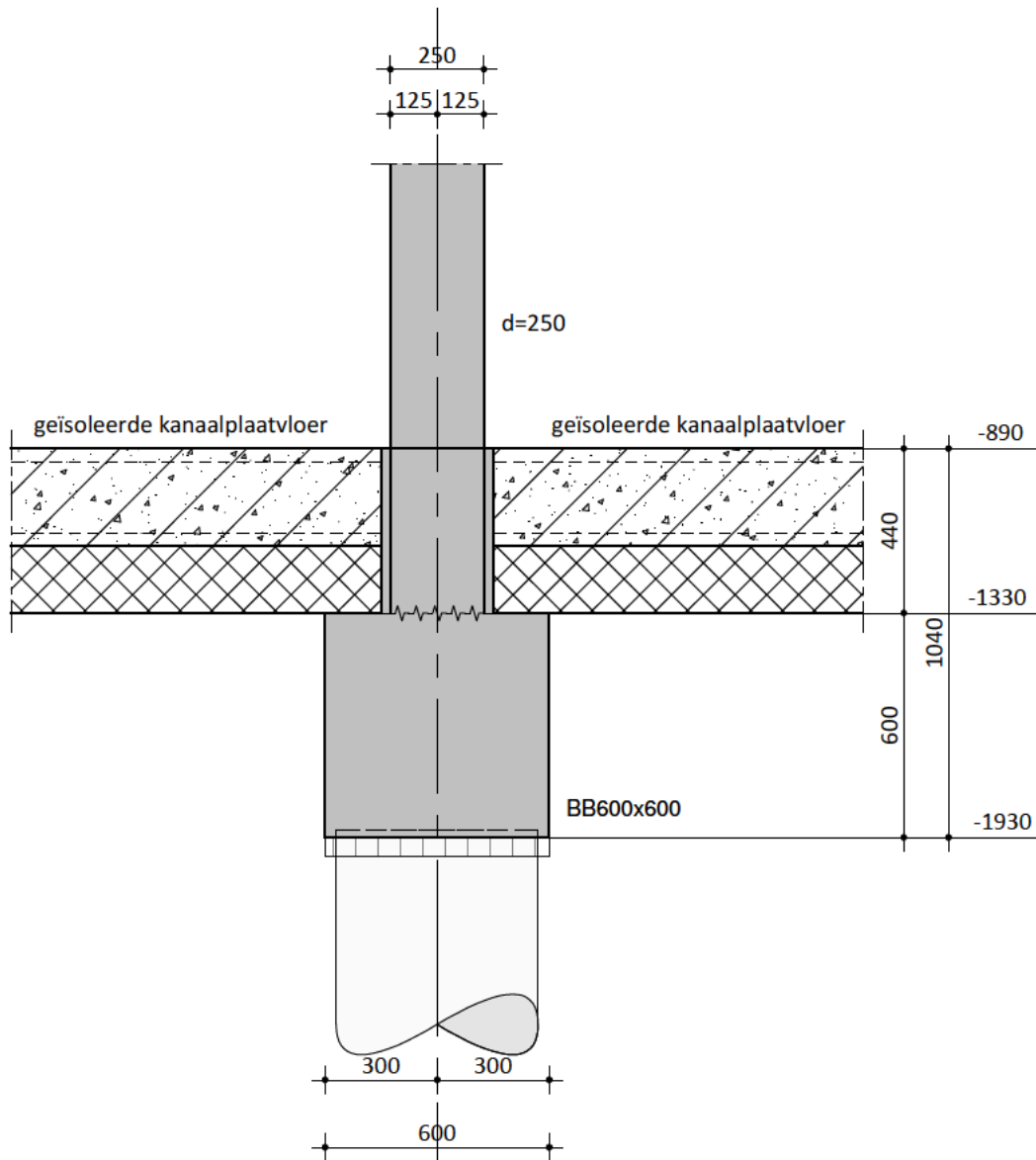

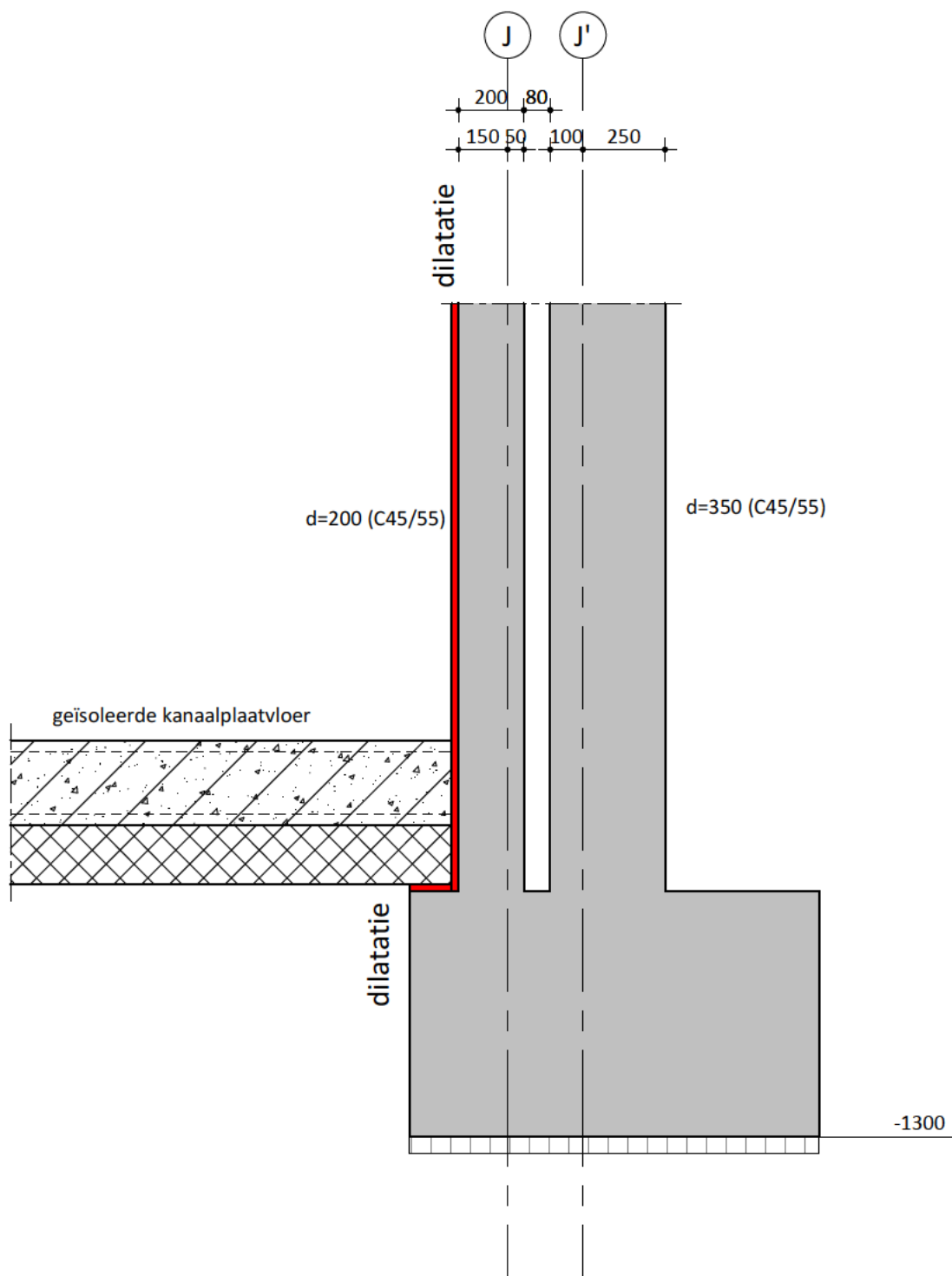

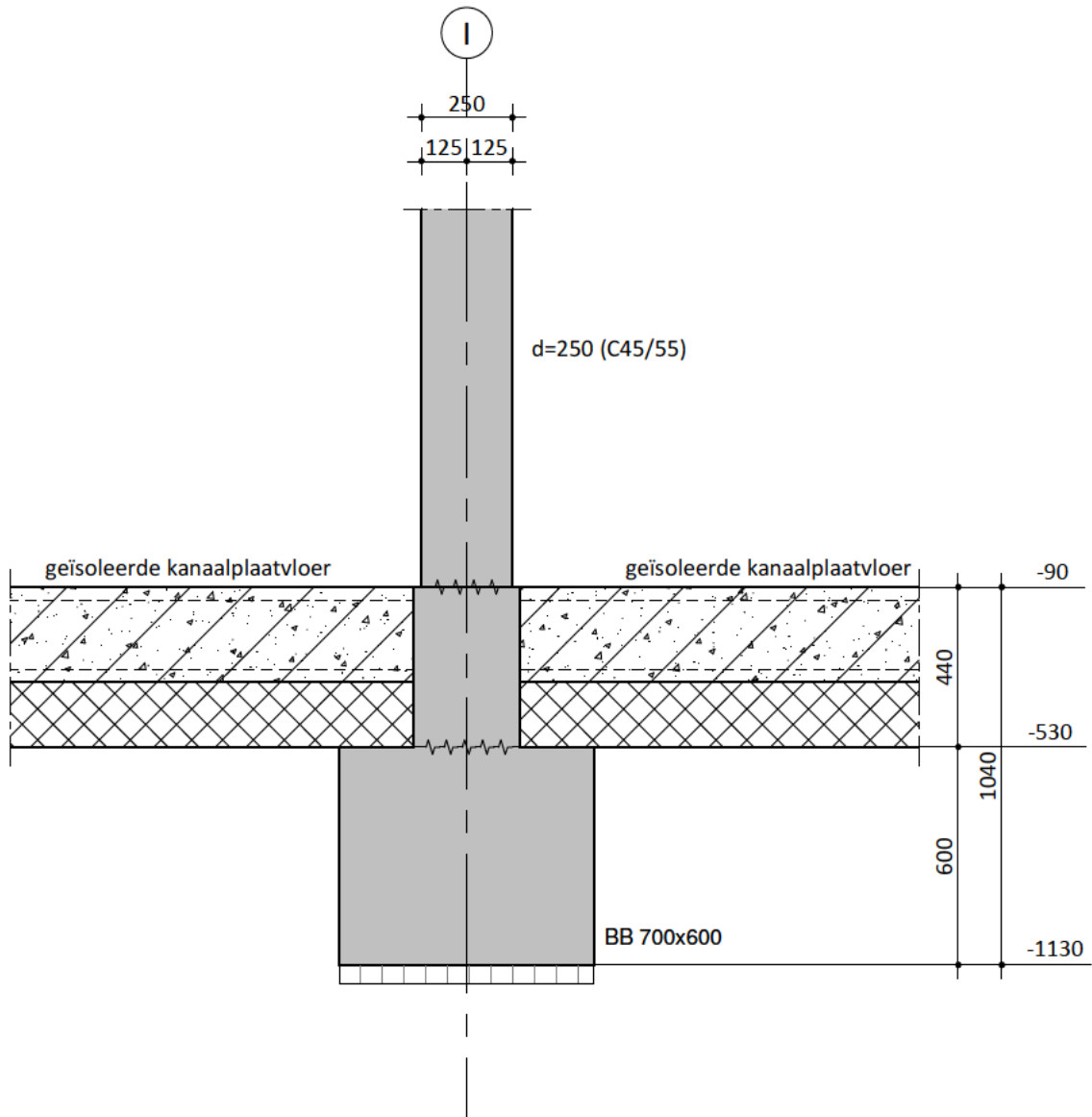

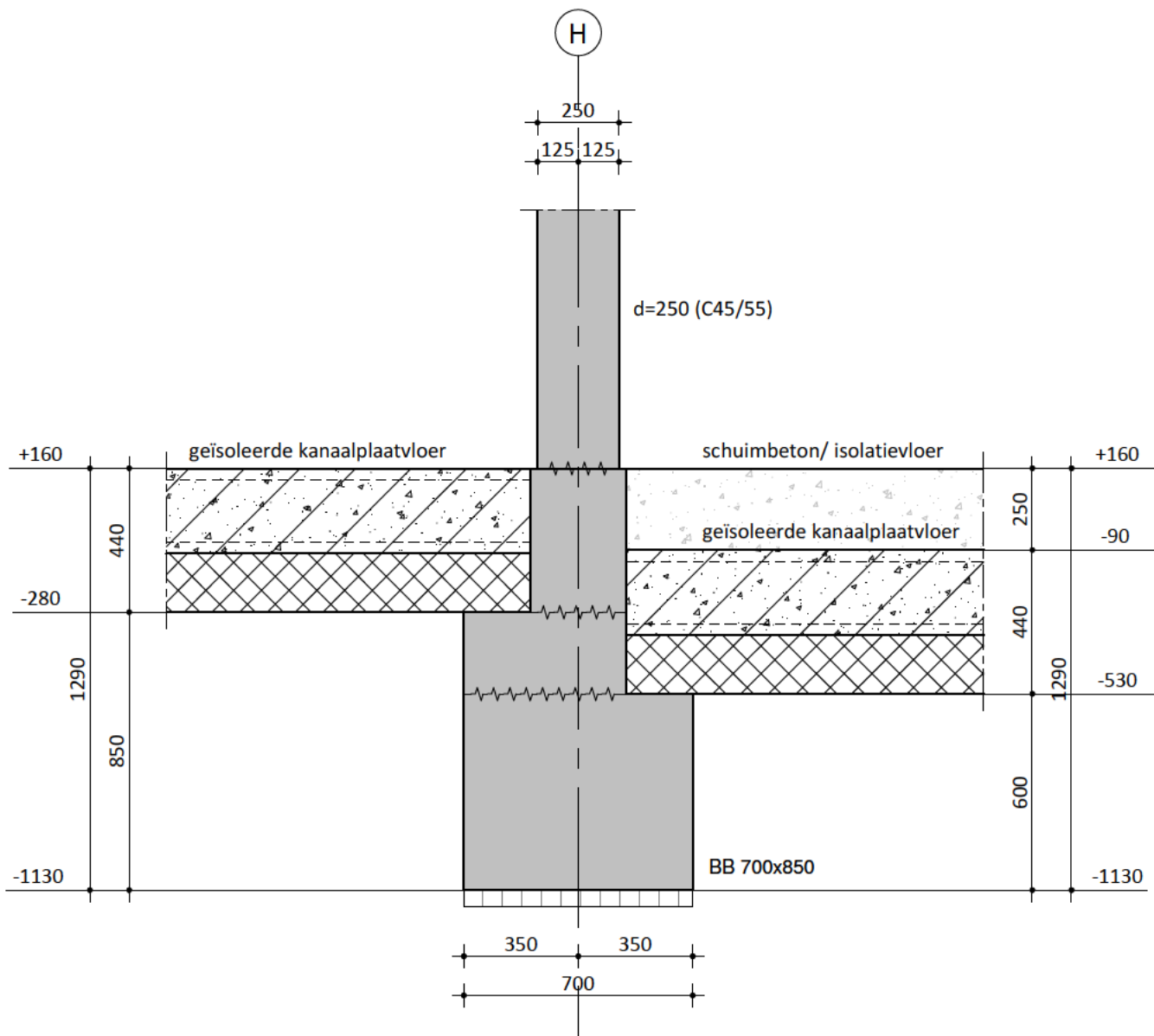



 <p>onderzoekt ontwerpt adviseert</p>	Project : Marktkwartier West te Amsterdam			
	Schaal : 1 : 20	Datum :	Onderdeel : Detail 0.60	
	Postbus 64, 7451 CH Holten T +31(0)548 85 33 33 E info@avecodebondt.nl I www.avecodebondt.nl	1.0 06-03-2023	Formaat : A4	Status : Definitief
		2.0 16-06-2023	Projectnummer:	Tekeningnummer:
3.0 15-12-2023	214570	D-0.60		

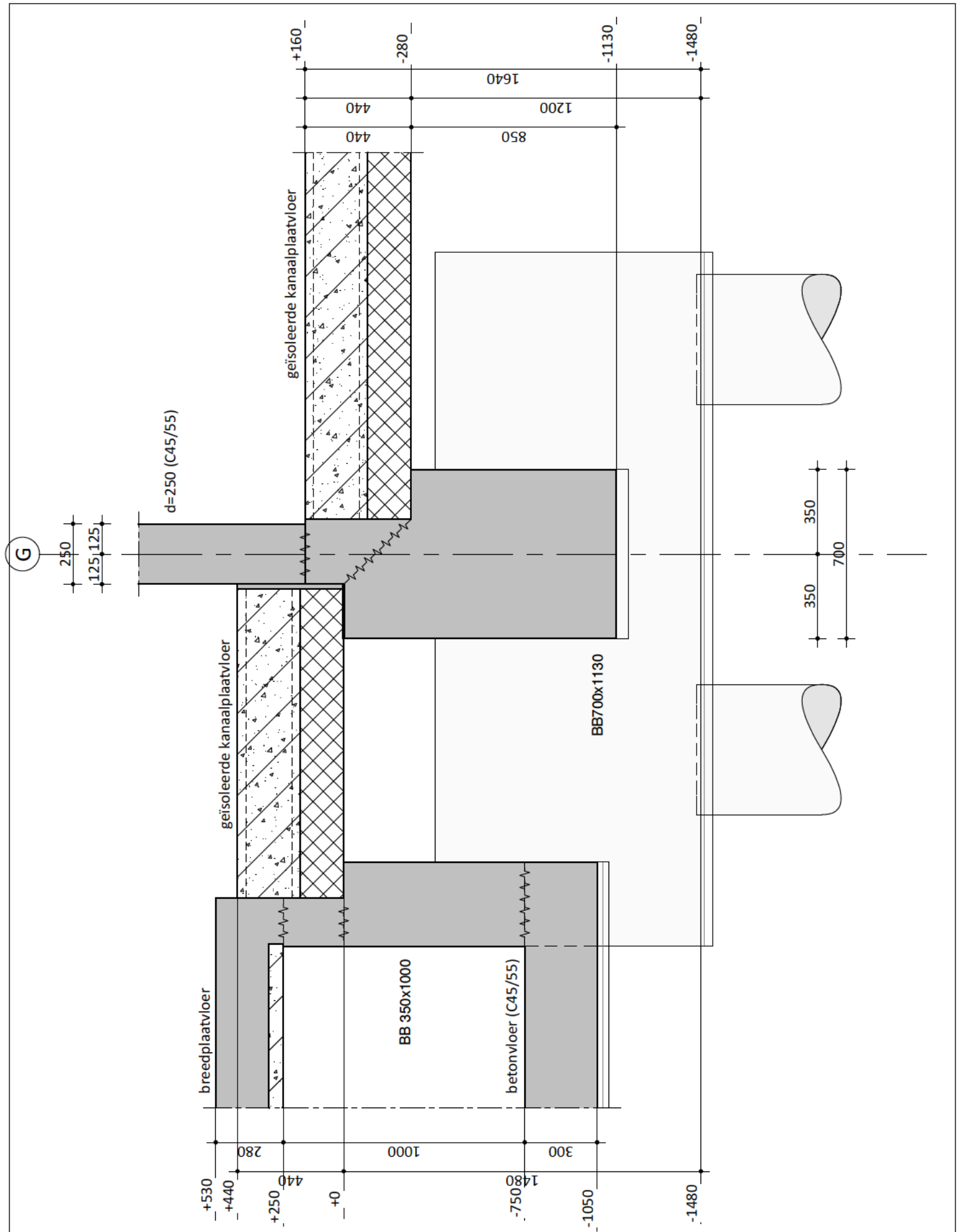

Project : Marktkwartier West te Amsterdam			
Schaal : 1 : 20	Datum :	Onderdeel : Detail 0.61	
Postbus 64, 7451 CH Holten T +31(0)548 85 33 33 E info@avecodebondt.nl I www.avecodebondt.nl	1.0	06-03-2023	Formaat : A4
	2.0	16-06-2023	Projectnummer:
	3.0	15-12-2023	214570
			Status : Definitief
			Tekeningnummer: D-0.61

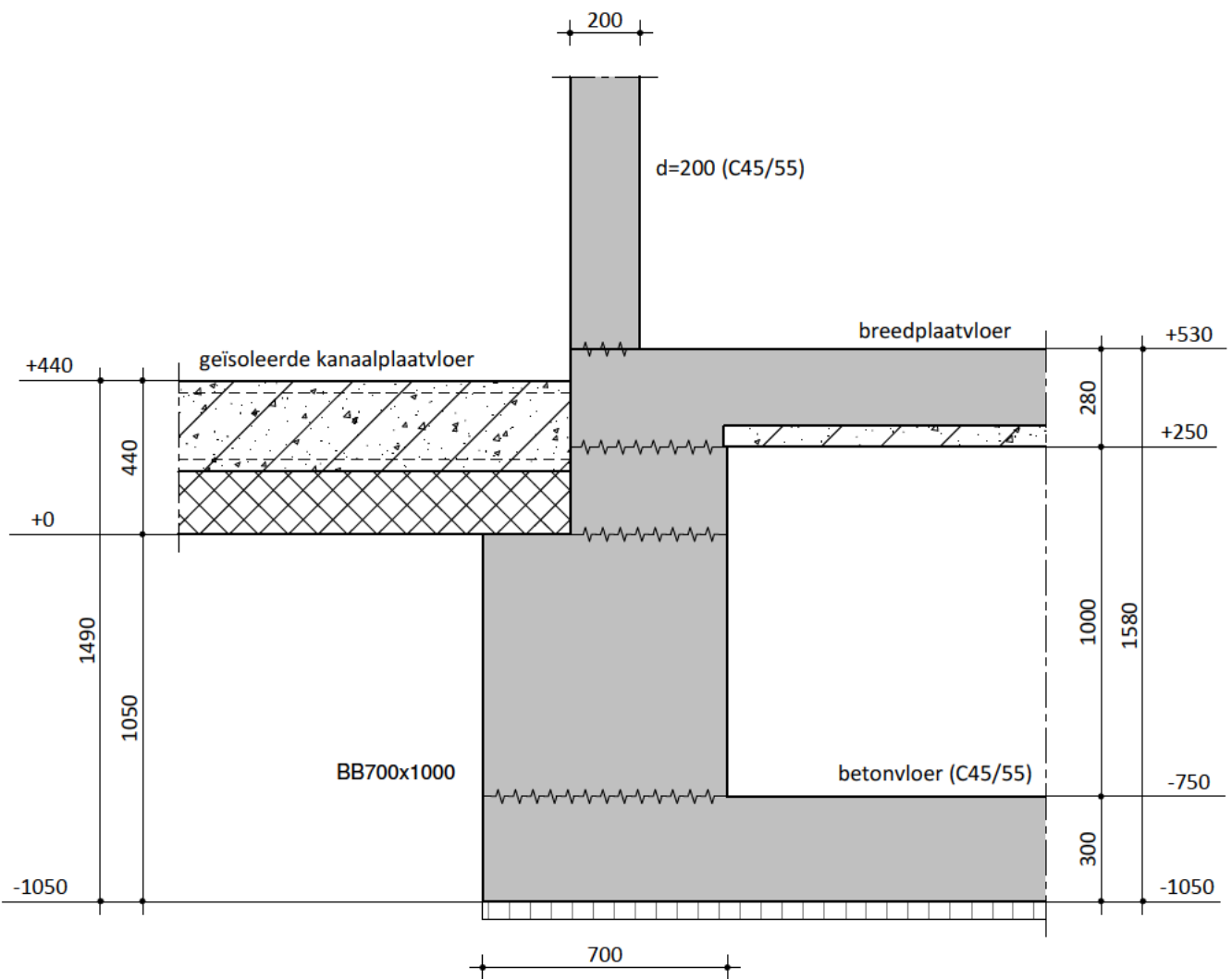

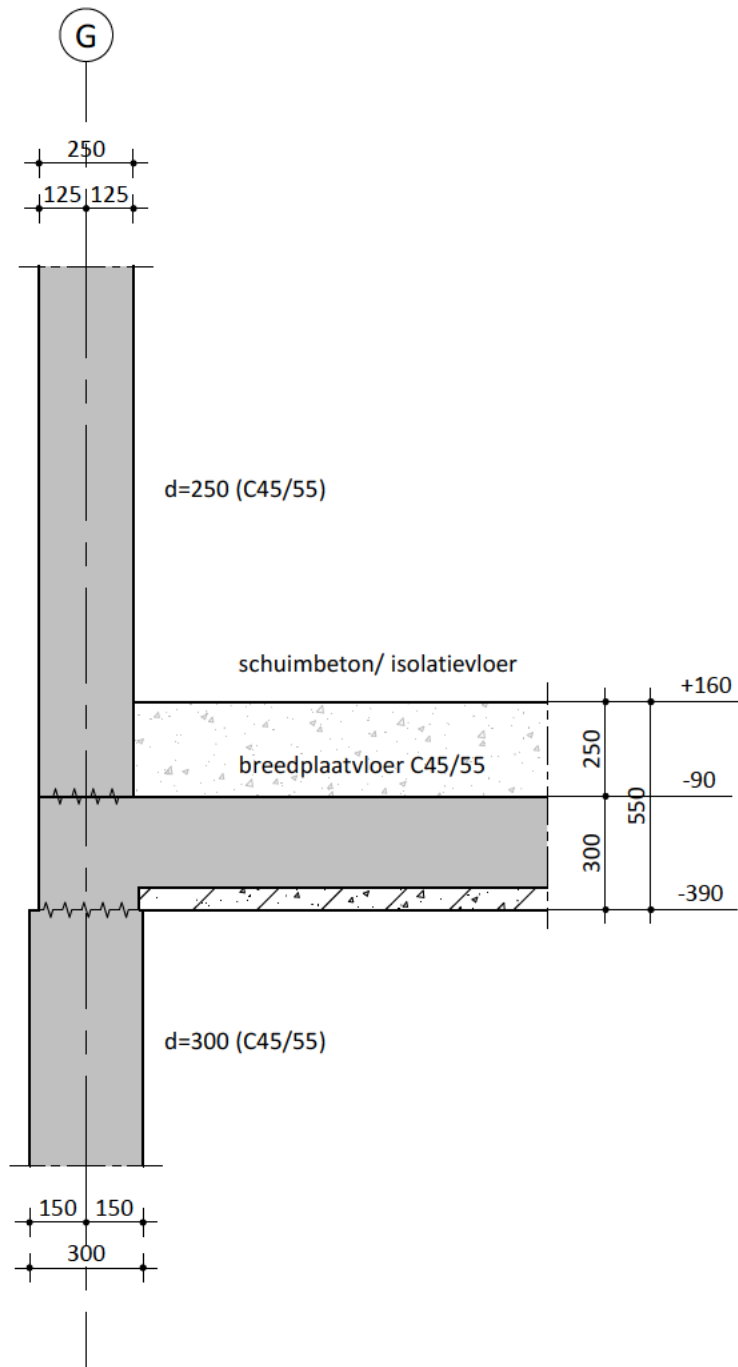

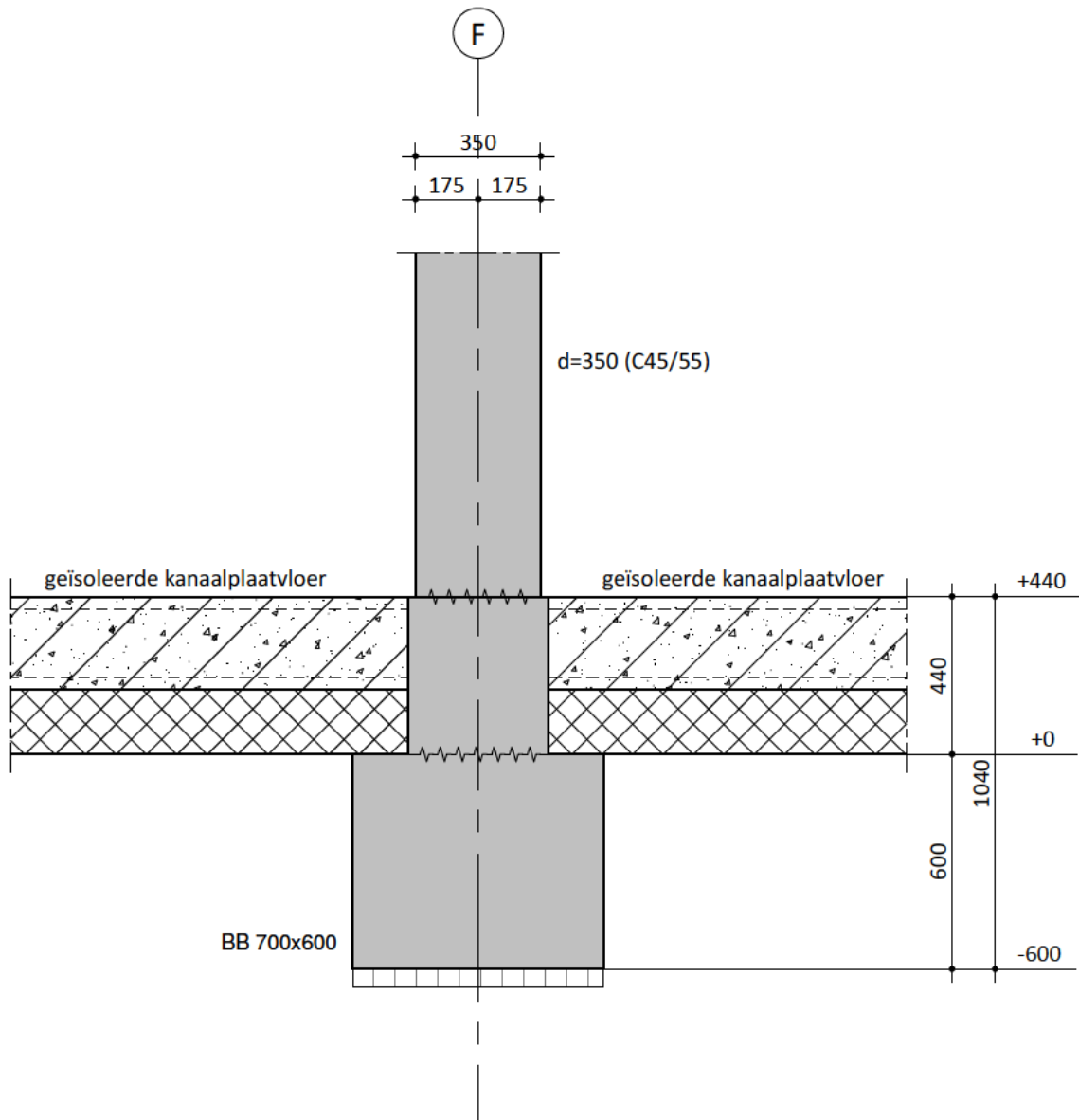

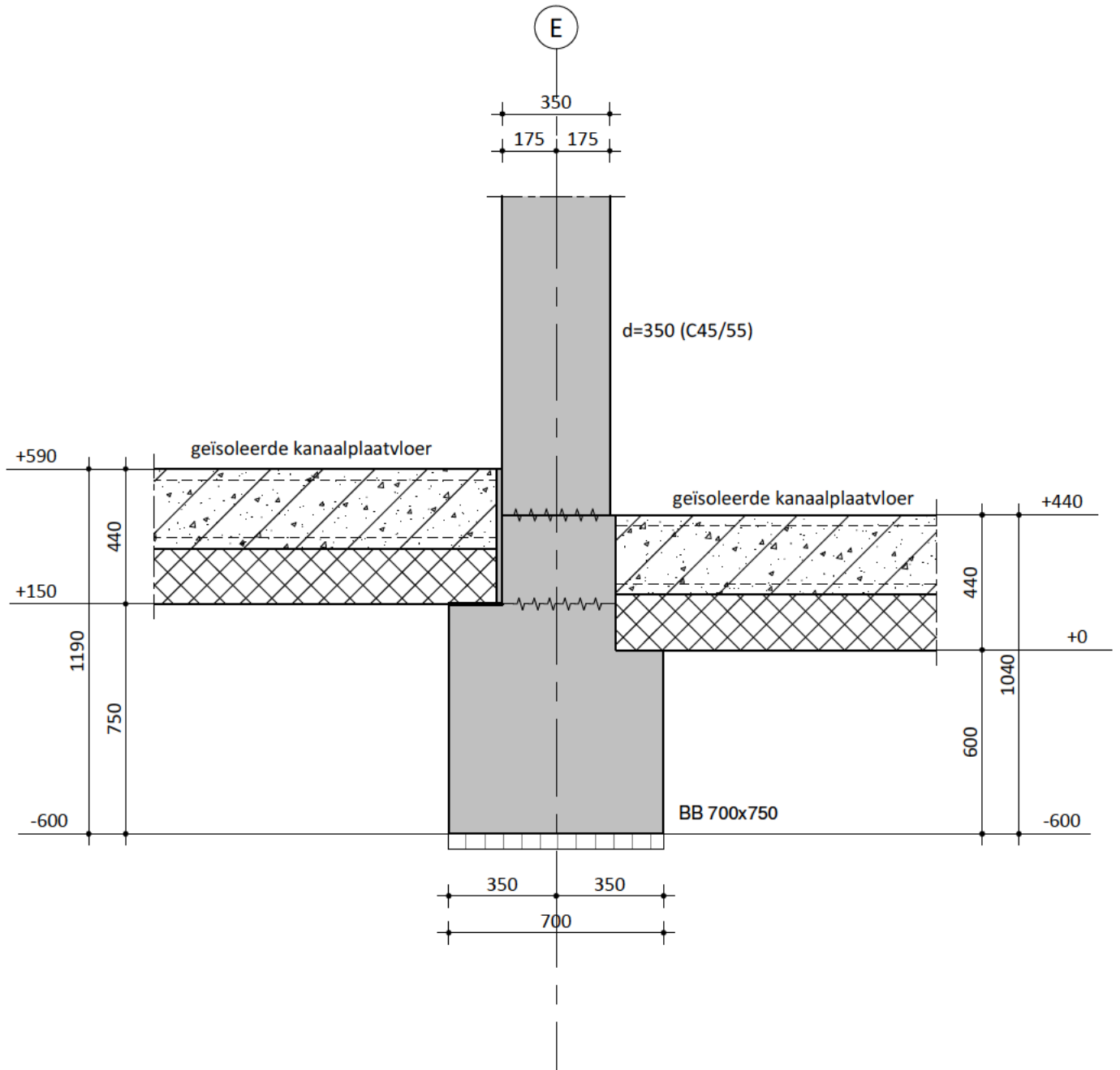

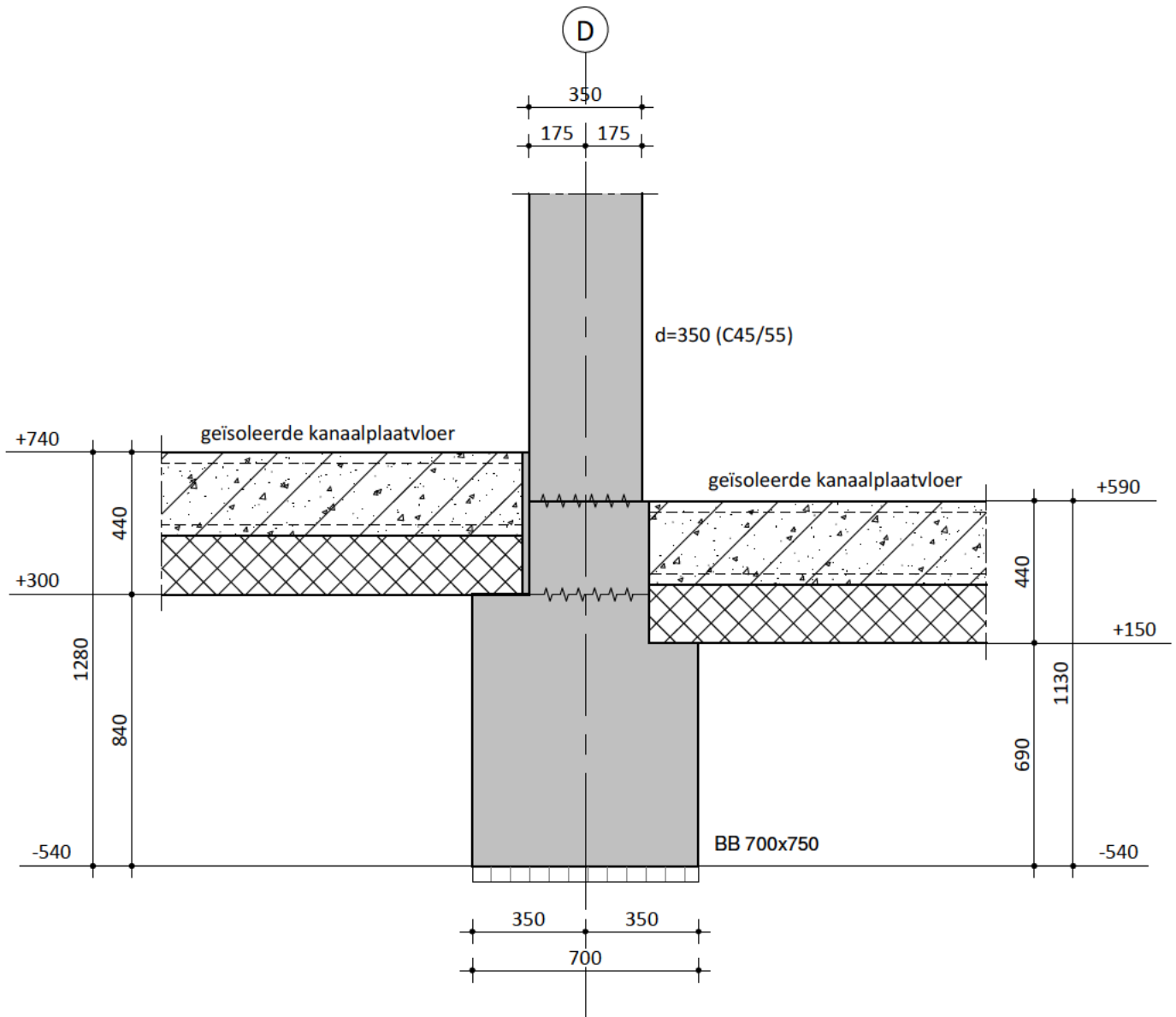

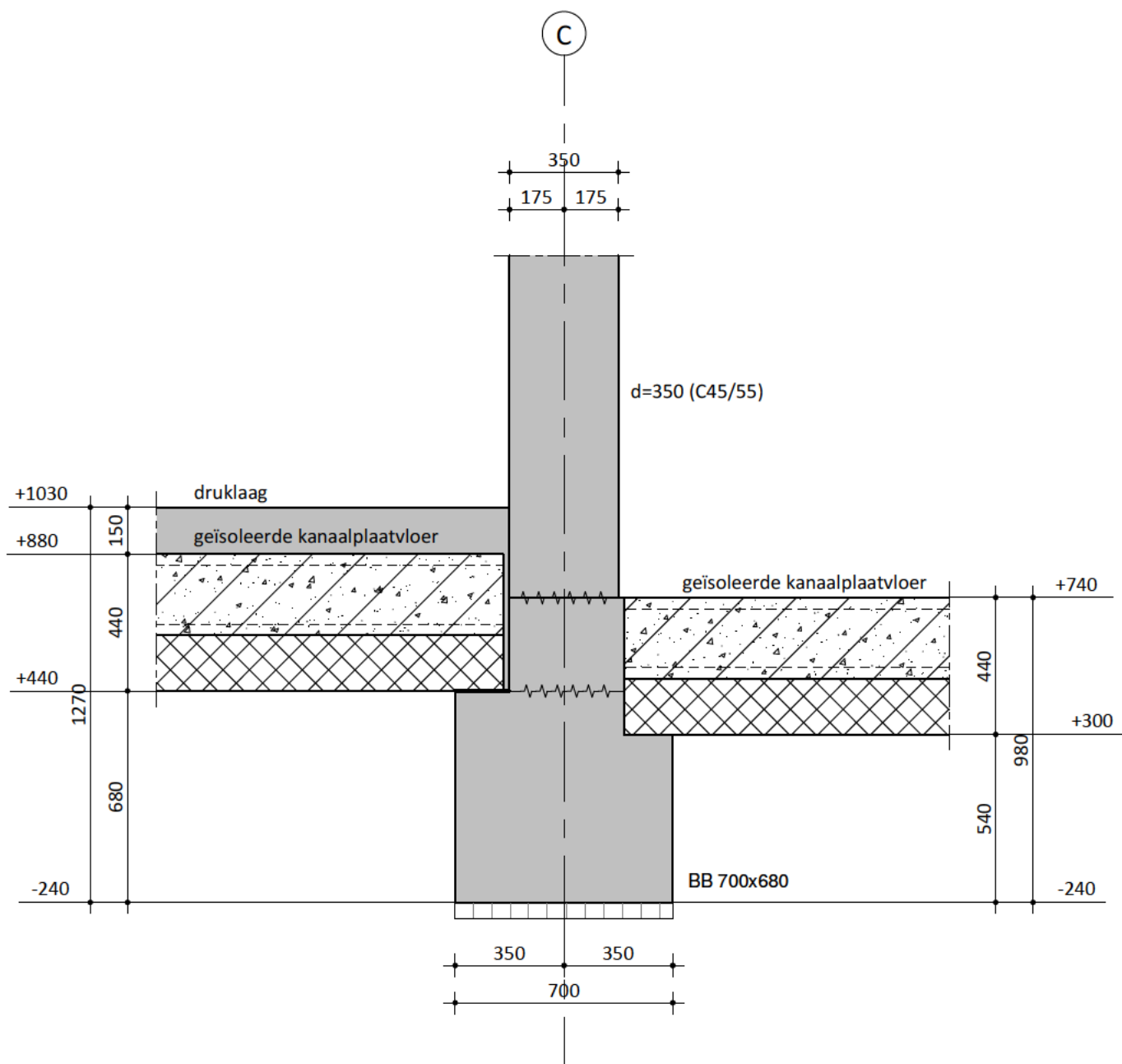



 <p>onderzoekt ontwerpt adviseert</p>	Project : Marktkwartier West te Amsterdam			
	Schaal : 1 : 20	Datum :	Onderdeel : Detail 0.67	
	Postbus 64, 7451 CH Holten T +31(0)548 85 33 33 E info@avecodebondt.nl I www.avecodebondt.nl	1.0 06-03-2023	Formaat : A4	Status : Definitief
		2.0 16-06-2023	Projectnummer:	Tekeningnummer:
	3.0 15-12-2023	214570	D-0.67	

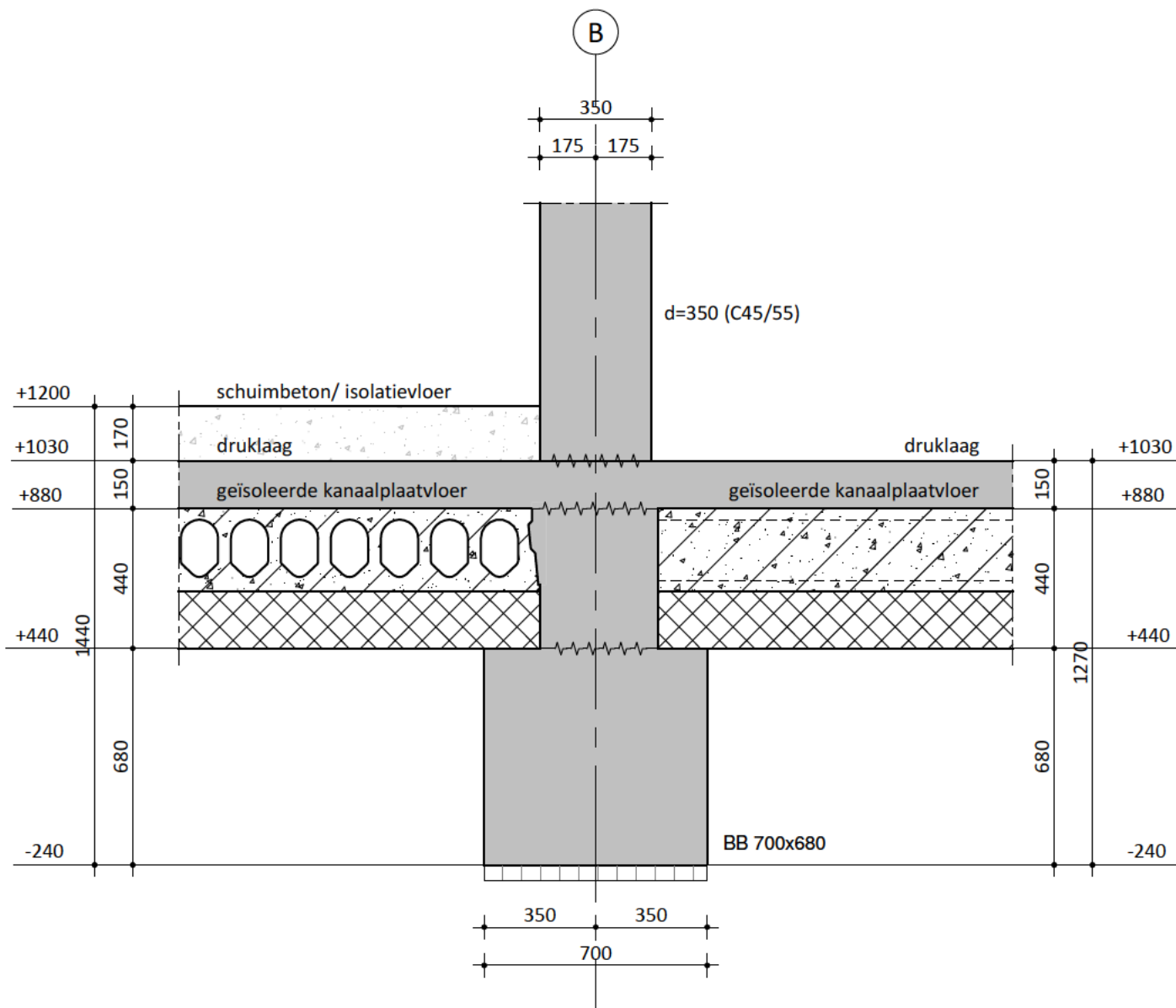

 <p>onderzoekt ontwerpt adviseert</p>	Project : Marktkwartier West te Amsterdam			
	Schaal : 1 : 20	Datum :	Onderdeel : Detail 0.68	
	Postbus 64, 7451 CH Holten T +31(0)548 85 33 33 E info@avecodebondt.nl I www.avecodebondt.nl	1.0 06-03-2023	Formaat : A4	Status : Definitief
		2.0 16-06-2023	Projectnummer:	Tekeningnummer:
	3.0 15-12-2023	214570	D-0.68	

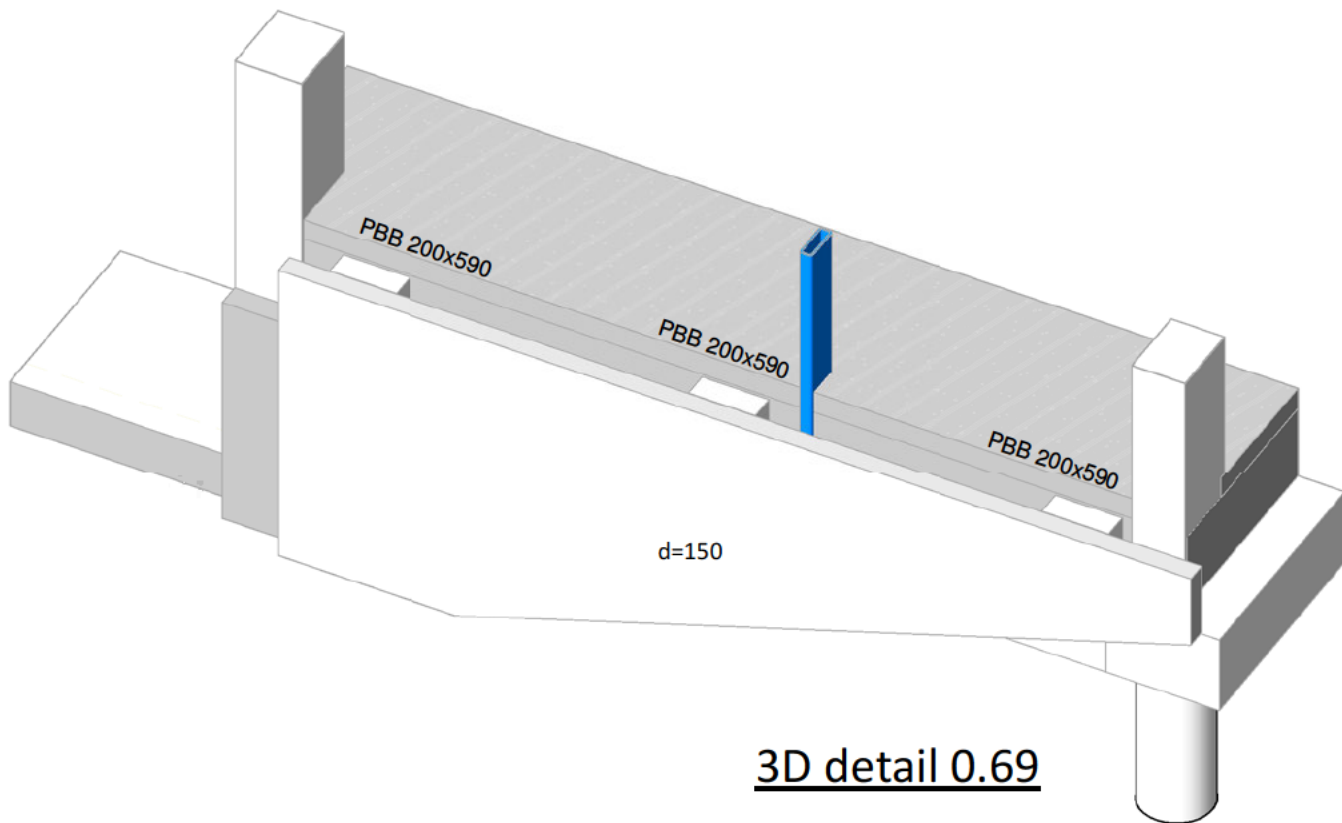

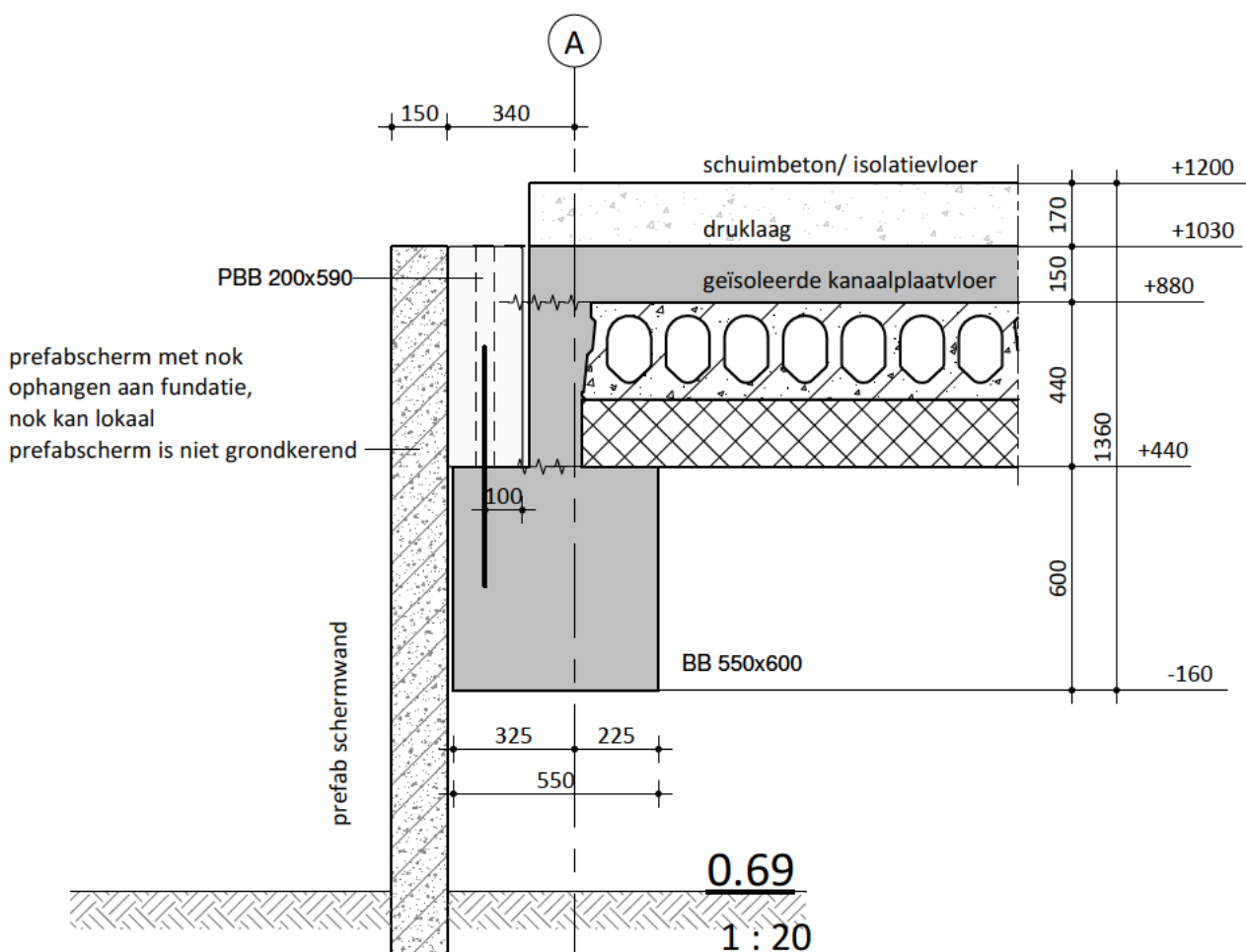

3D detail 0.69



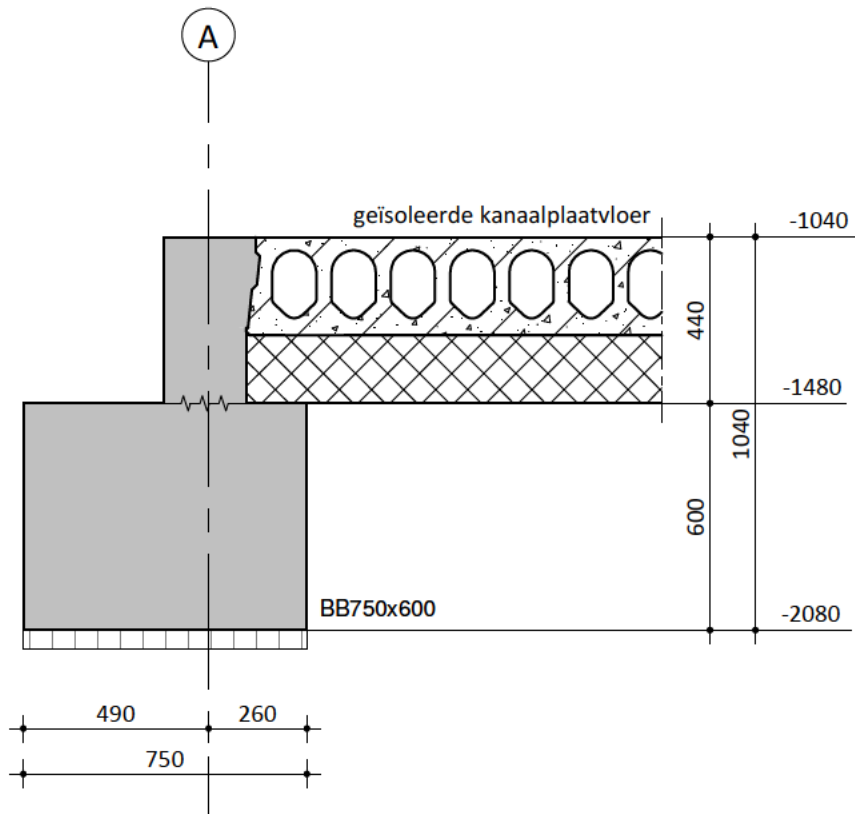

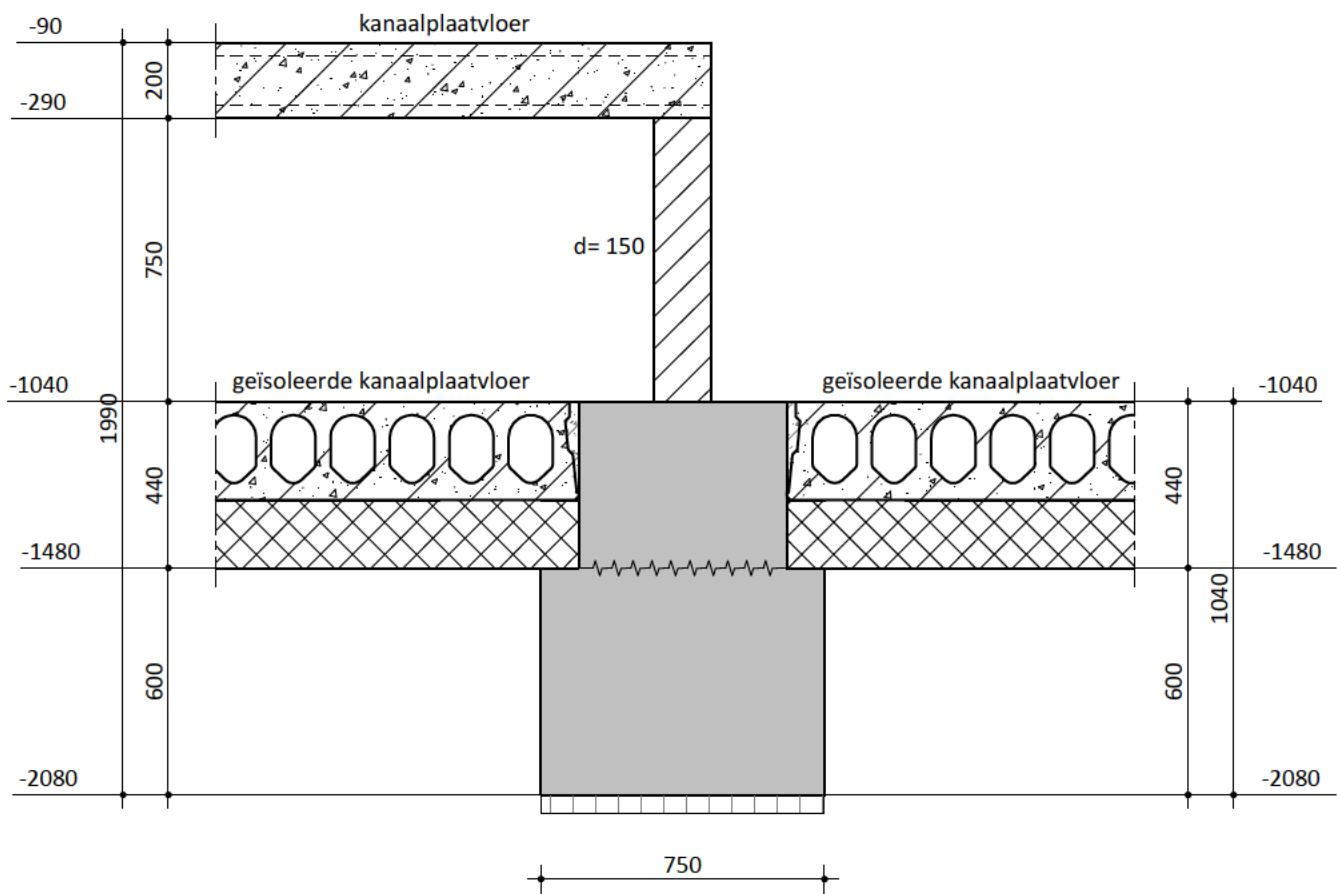
 <p>onderzoekt ontwerpt adviseert</p>	Project : Marktkwartier West te Amsterdam			
	Schaal : 1 : 20	Datum :	Onderdeel : Detail 0.69	
	Postbus 64, 7451 CH Holten T +31(0)548 85 33 33 E info@avecodebondt.nl I www.avecodebondt.nl	1.0 06-03-2023	Formaat : A4	Status : Definitief
		2.0 16-06-2023	Projectnummer:	Tekeningnummer:
	3.0 15-12-2023	214570	D-0.69	





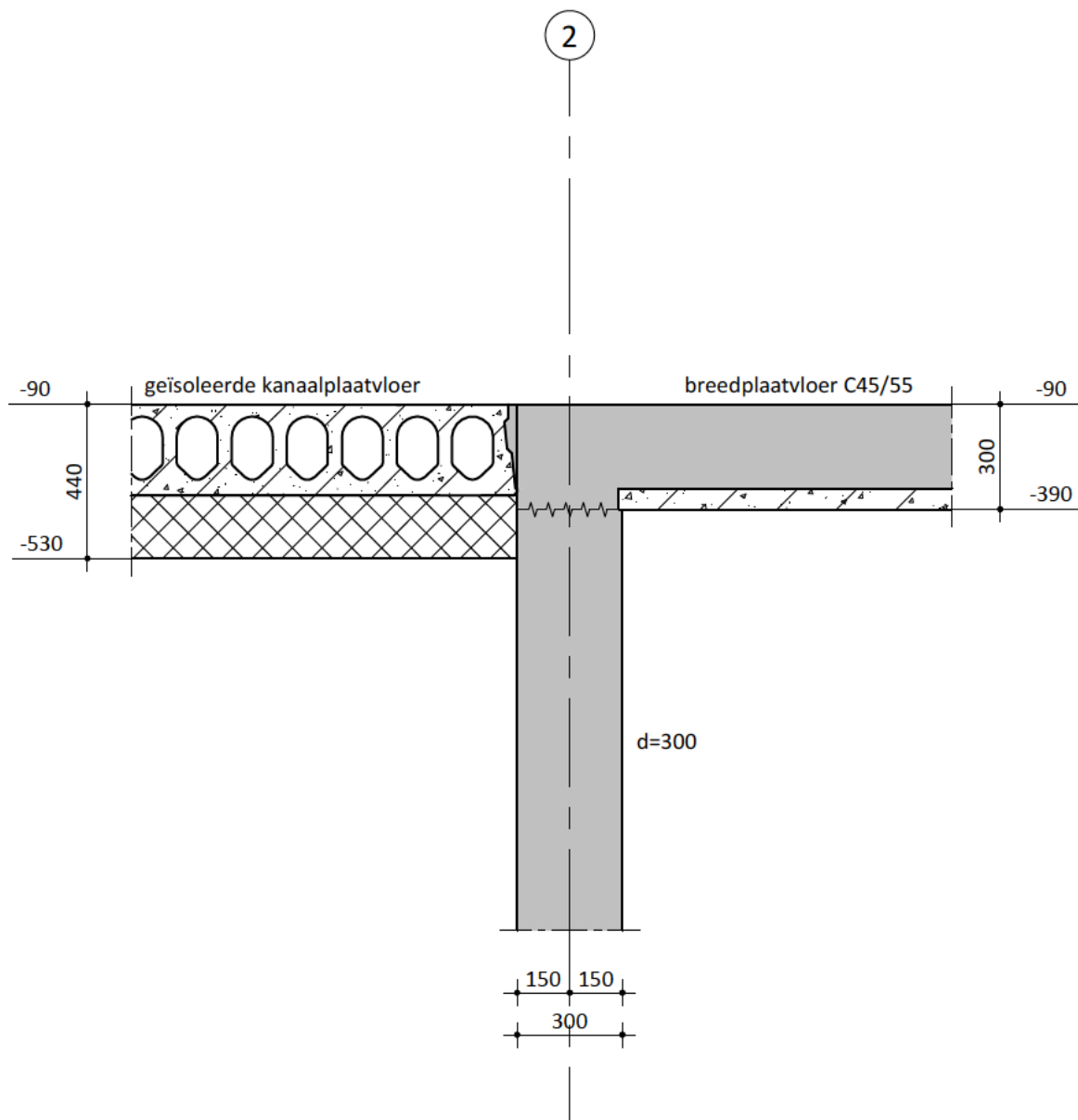

 <p>onderzoekt ontwerpt adviseert</p>	Project : Marktkwartier West te Amsterdam			
	Schaal : 1 : 20	Datum :	Onderdeel : Detail 0.71	
	Postbus 64, 7451 CH Holten T +31(0)548 85 33 33 E info@avecodebondt.nl I www.avecodebondt.nl	1.0 06-03-2023	Formaat : A4	Status : Definitief
		2.0 16-06-2023	Projectnummer:	Tekeningnummer:
	3.0 15-12-2023	214570	D-0.71	

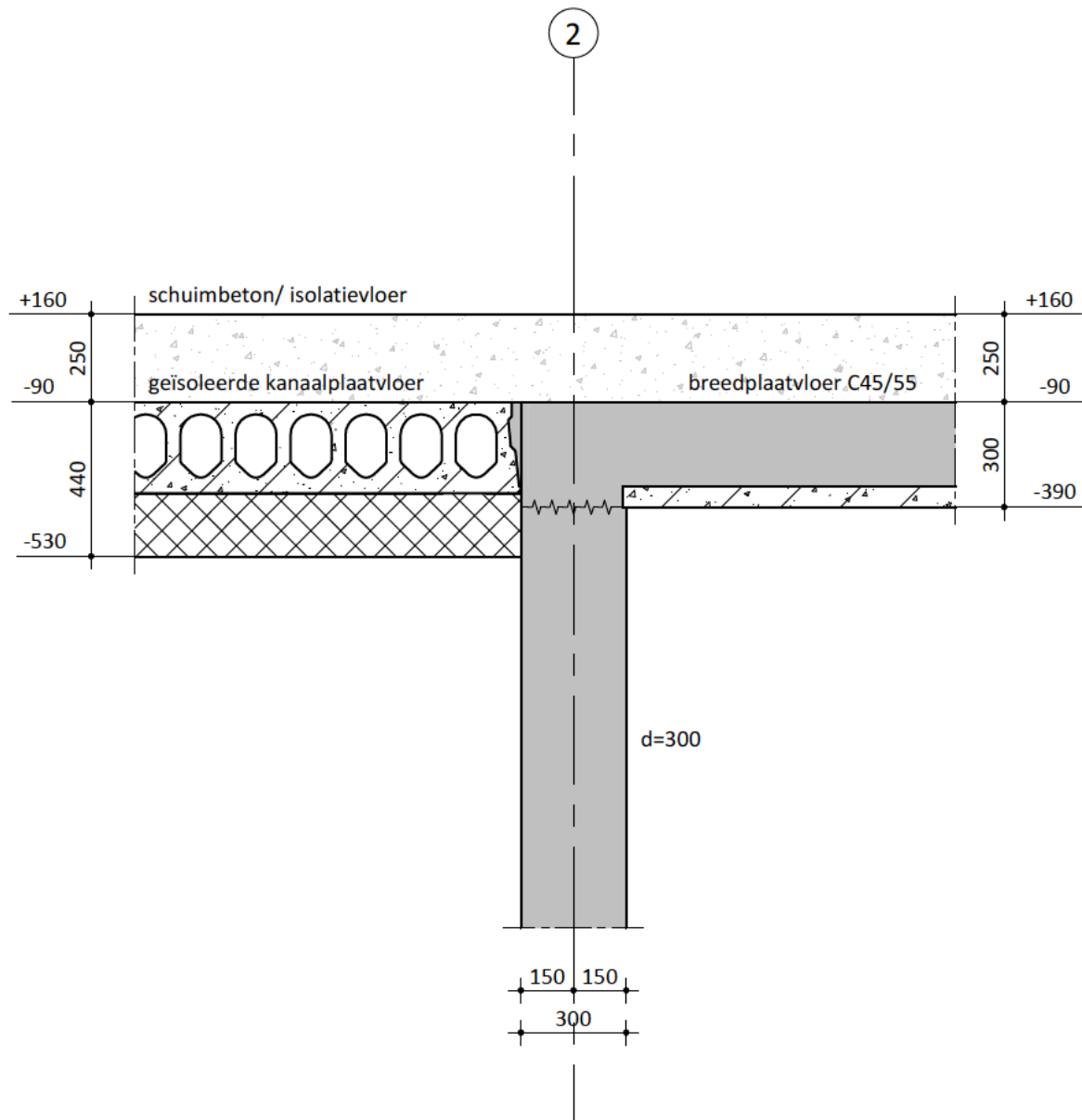

 <p>onderzoekt ontwerpt adviseert</p>	Project : Marktkwartier West te Amsterdam			
	Schaal : 1 : 20	Datum :	Onderdeel : Detail 0.72	
	Postbus 64, 7451 CH Holten T +31(0)548 85 33 33 E info@avecodebondt.nl I www.avecodebondt.nl	1.0 06-03-2023	Formaat : A4	Status : Definitief
		2.0 16-06-2023	Projectnummer:	Tekeningnummer:
3.0 15-12-2023	214570	D-0.72		



 <p>onderzoekt ontwerpt adviseert</p>	Project : Marktkwartier West te Amsterdam			
	Schaal : 1 : 20	Datum :	Onderdeel : Detail 0.73	
	Postbus 64, 7451 CH Holten T +31(0)548 85 33 33 E info@avecodebondt.nl I www.avecodebondt.nl	1.0 06-03-2023	Formaat : A4	Status : Definitief
		2.0 16-06-2023	Projectnummer: 214570	Tekeningnummer: D-0.73
	3.0 15-12-2023			

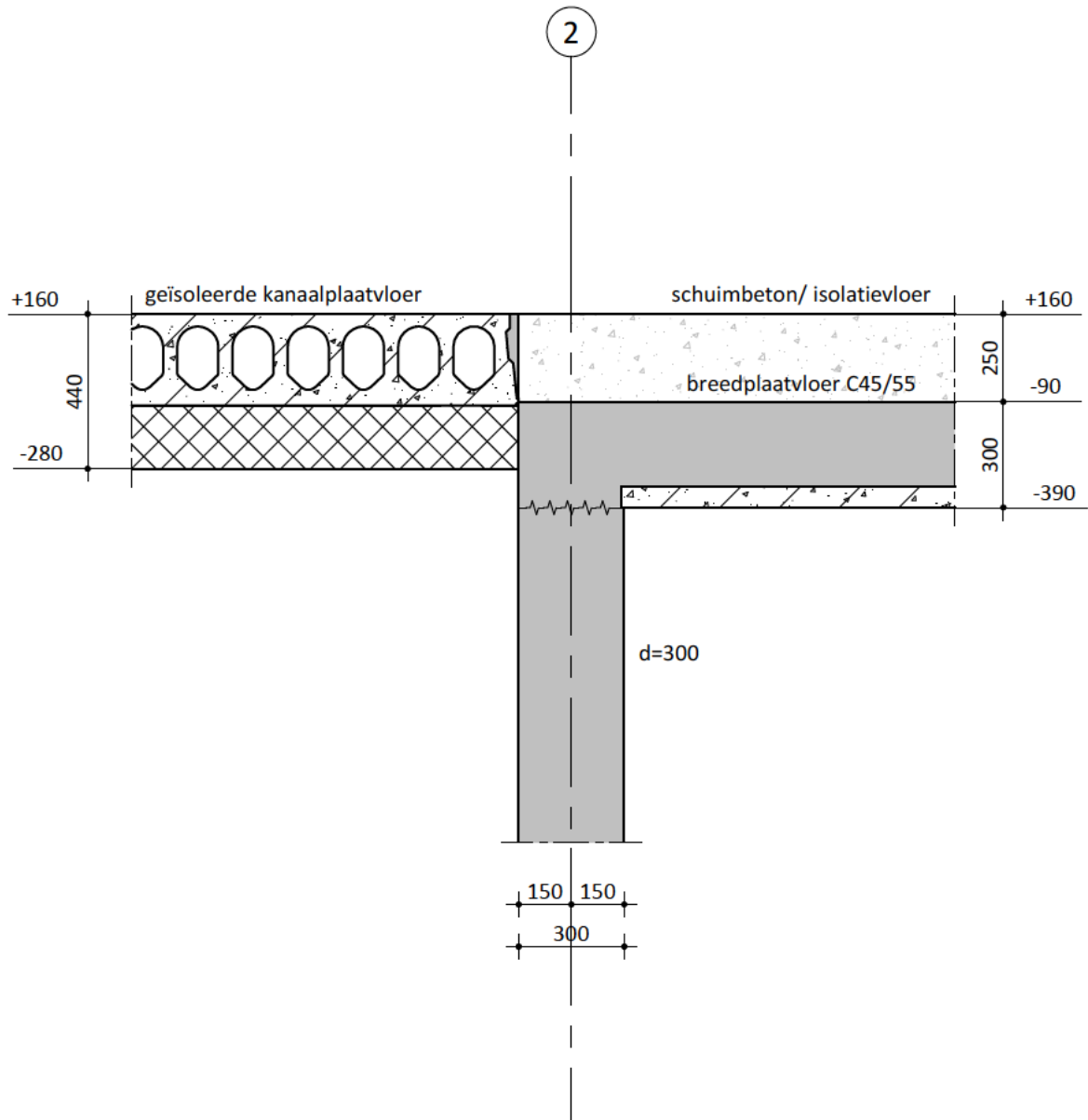

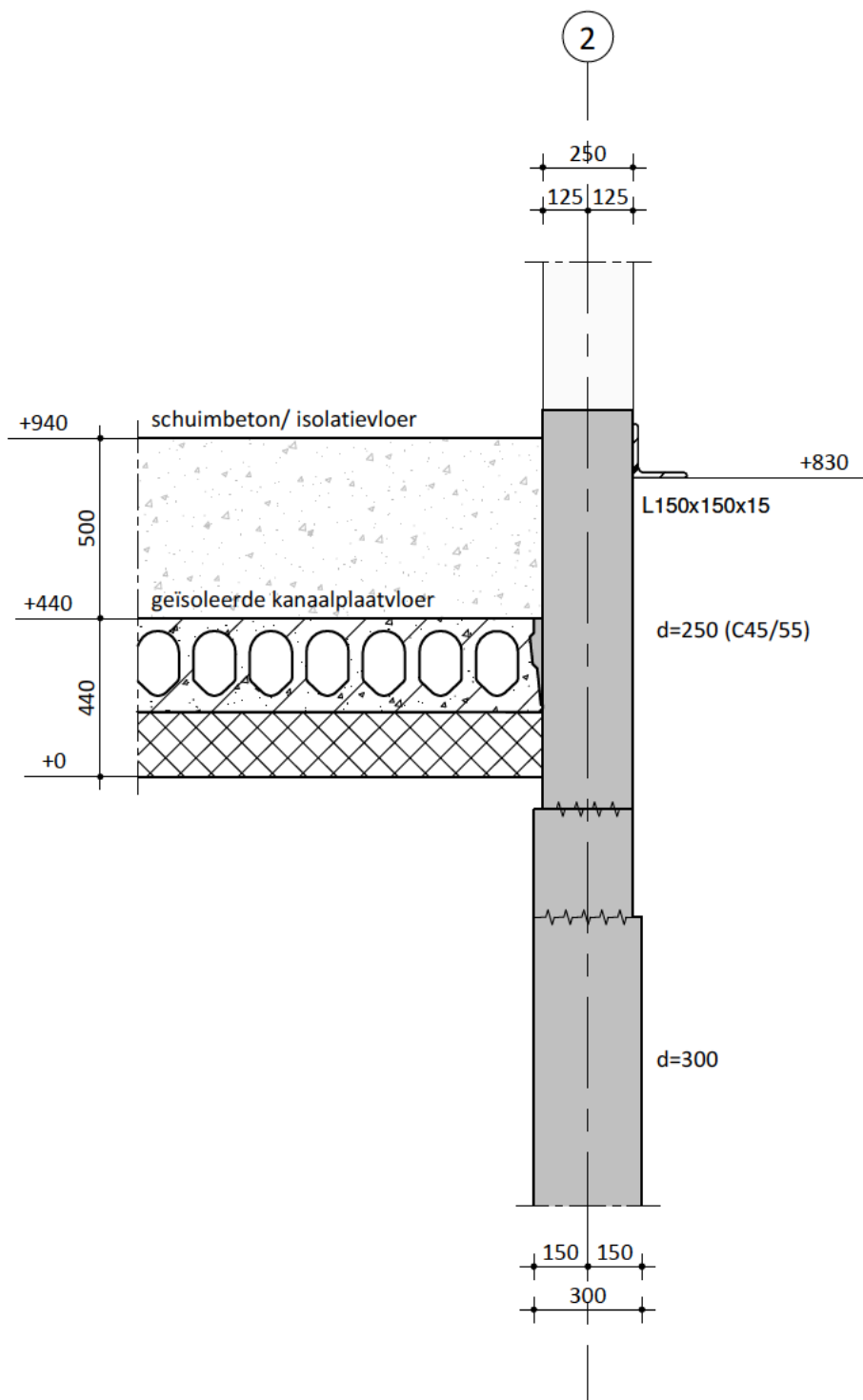

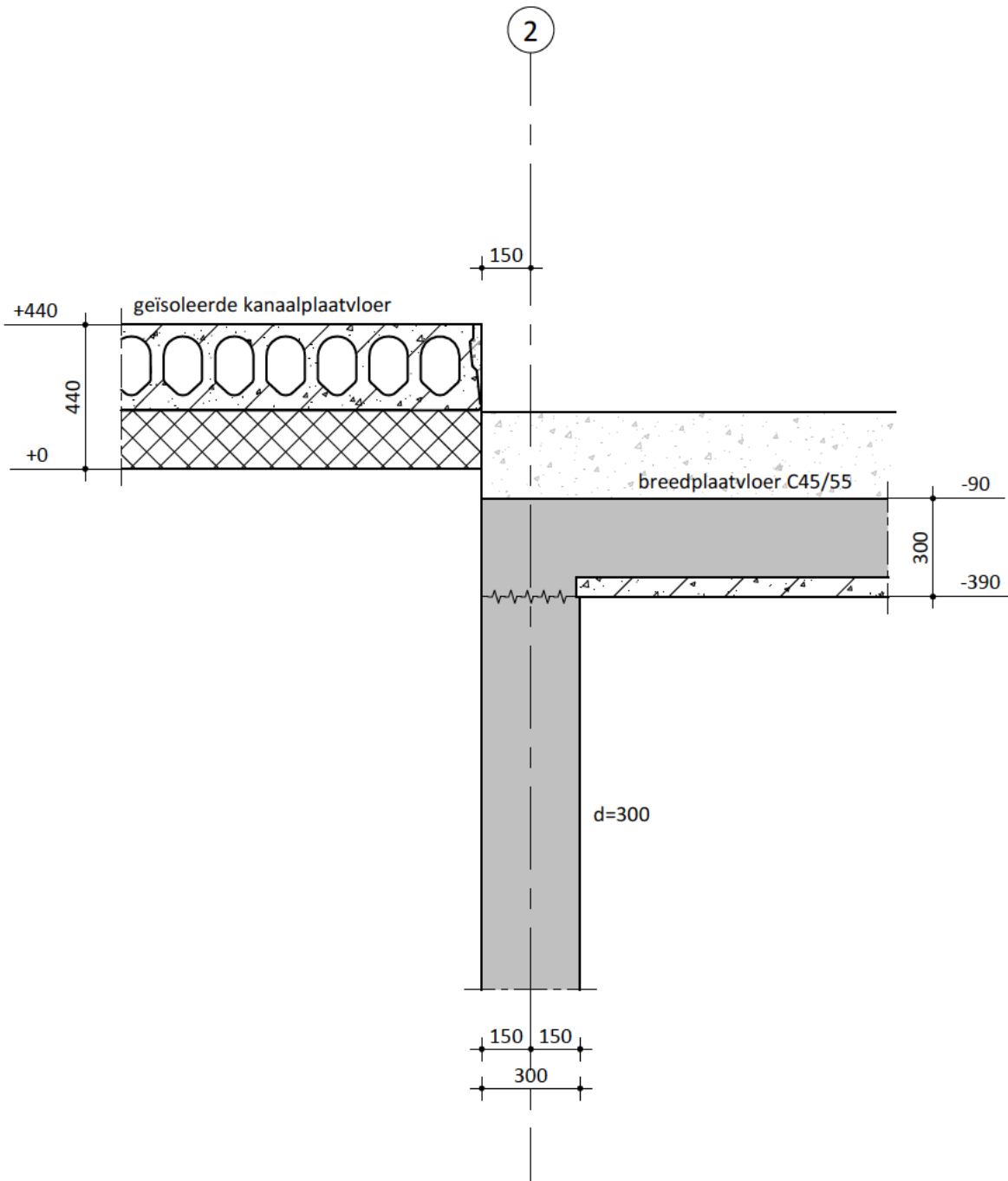

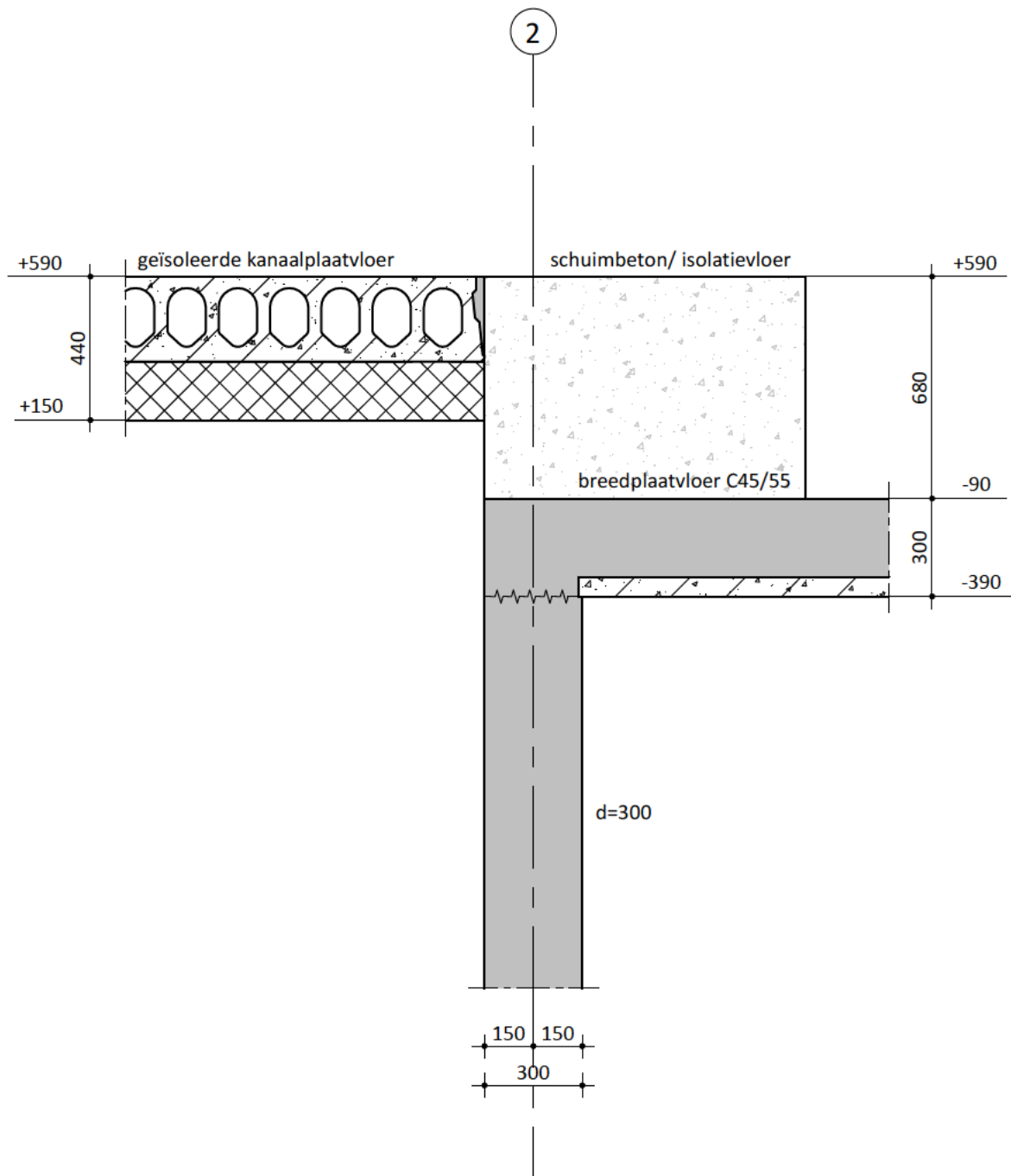

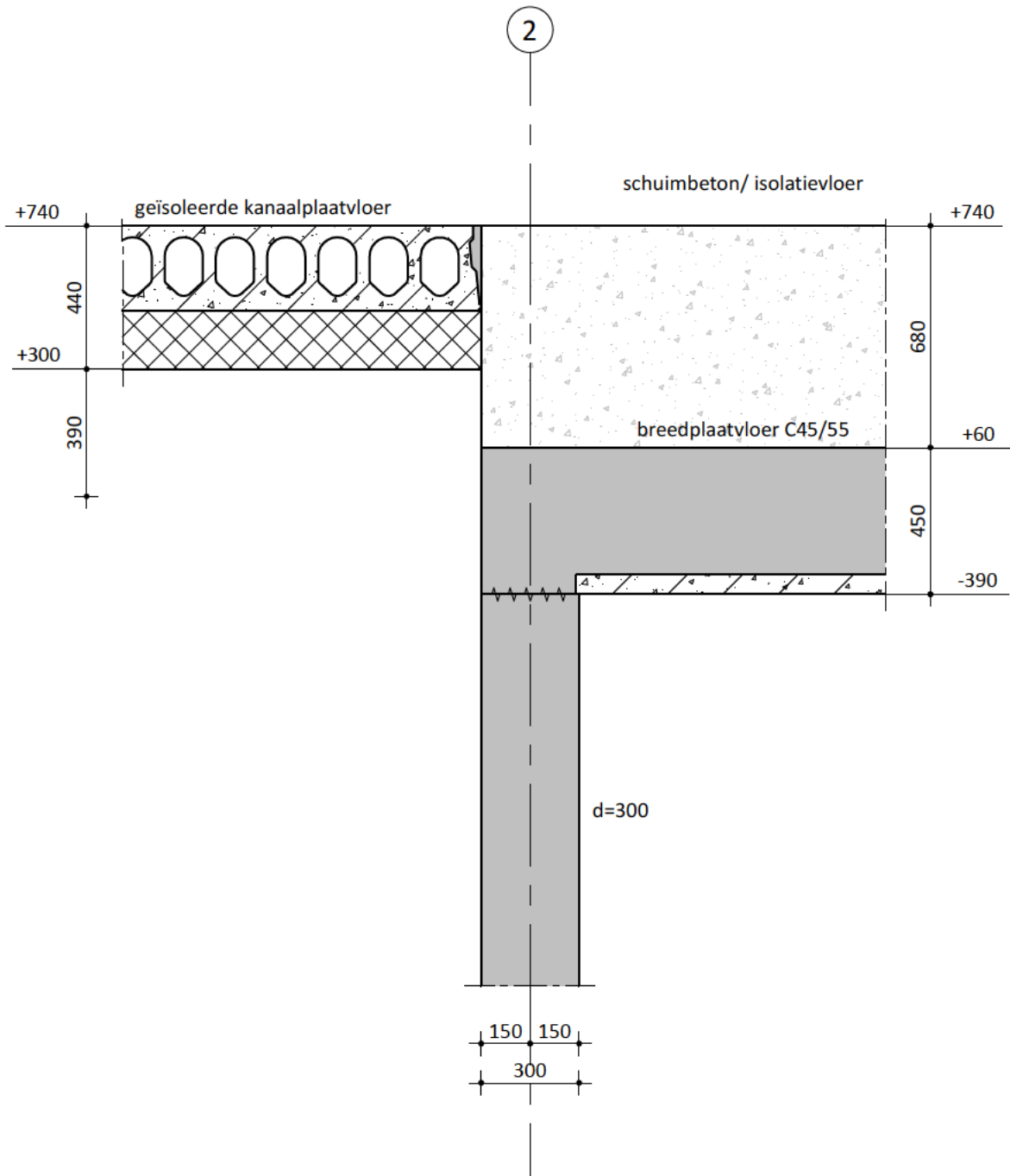

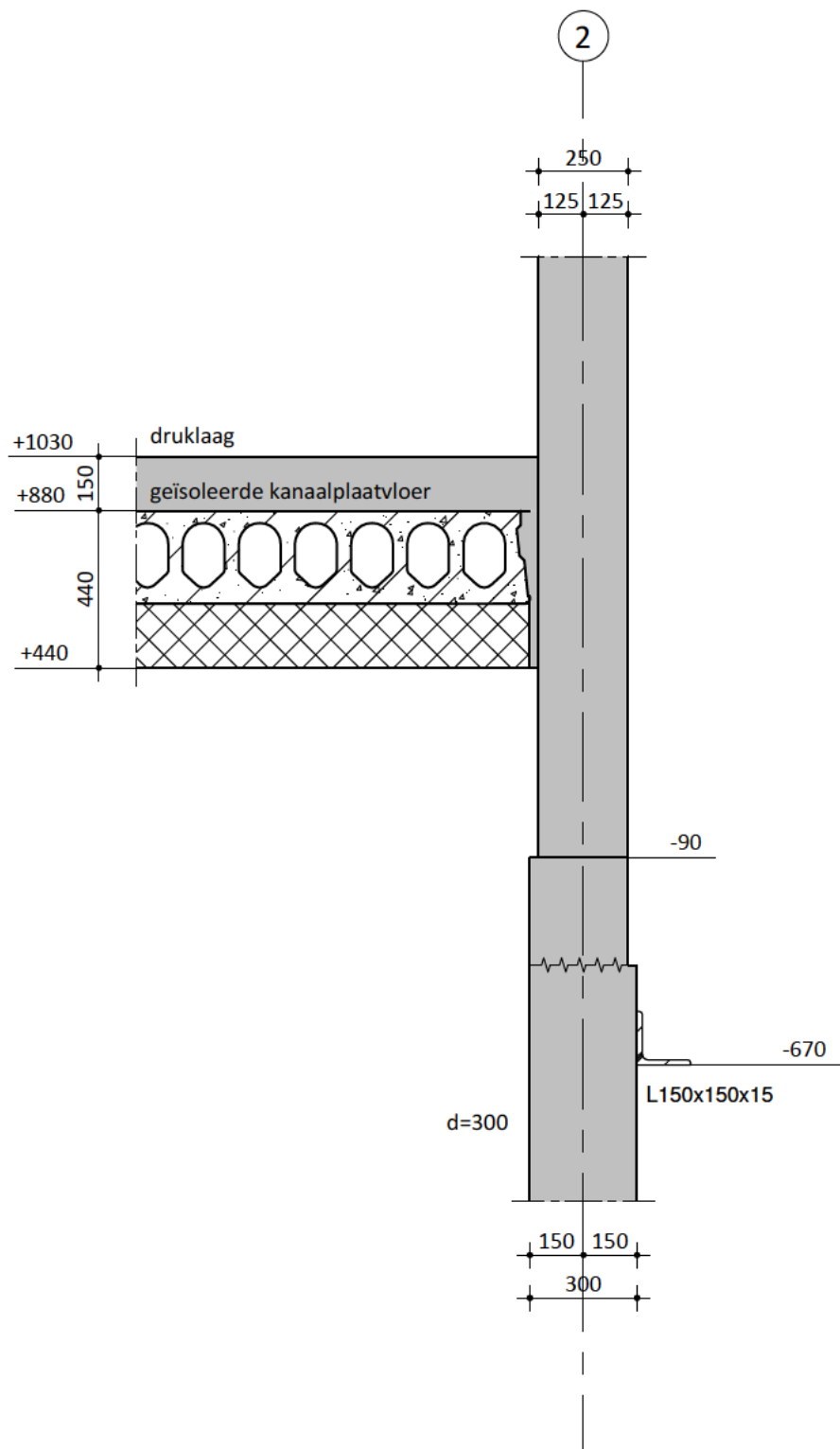

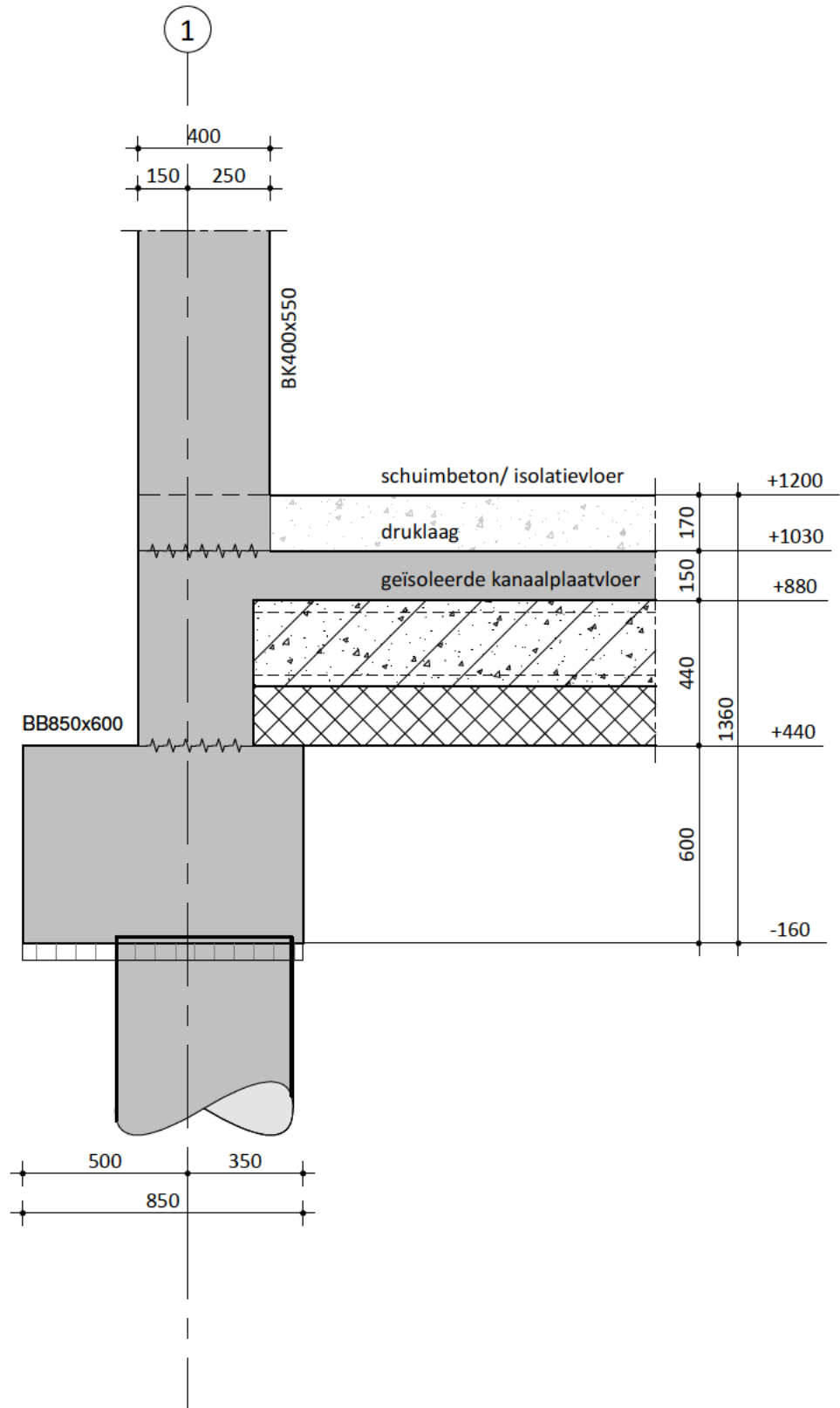

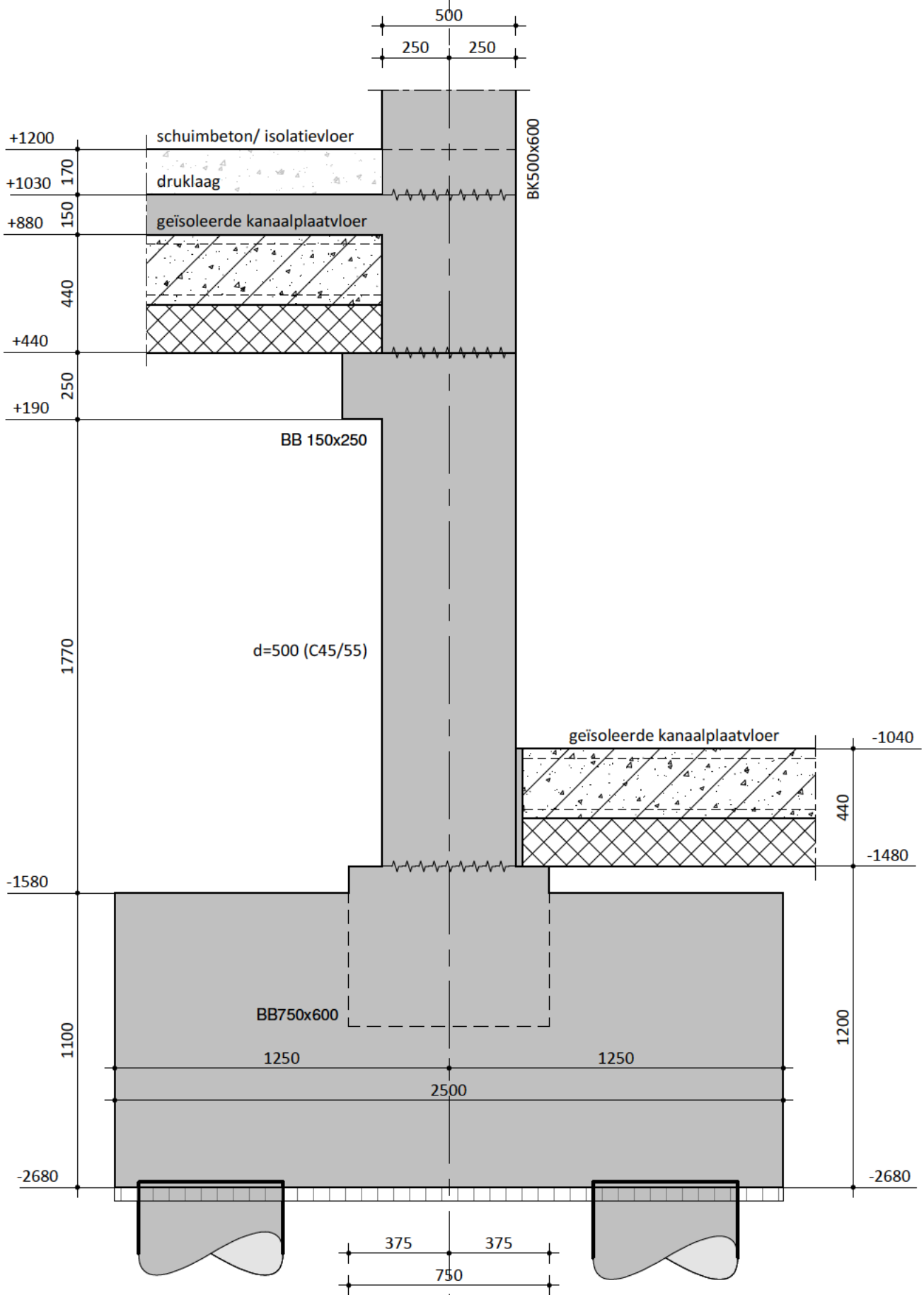

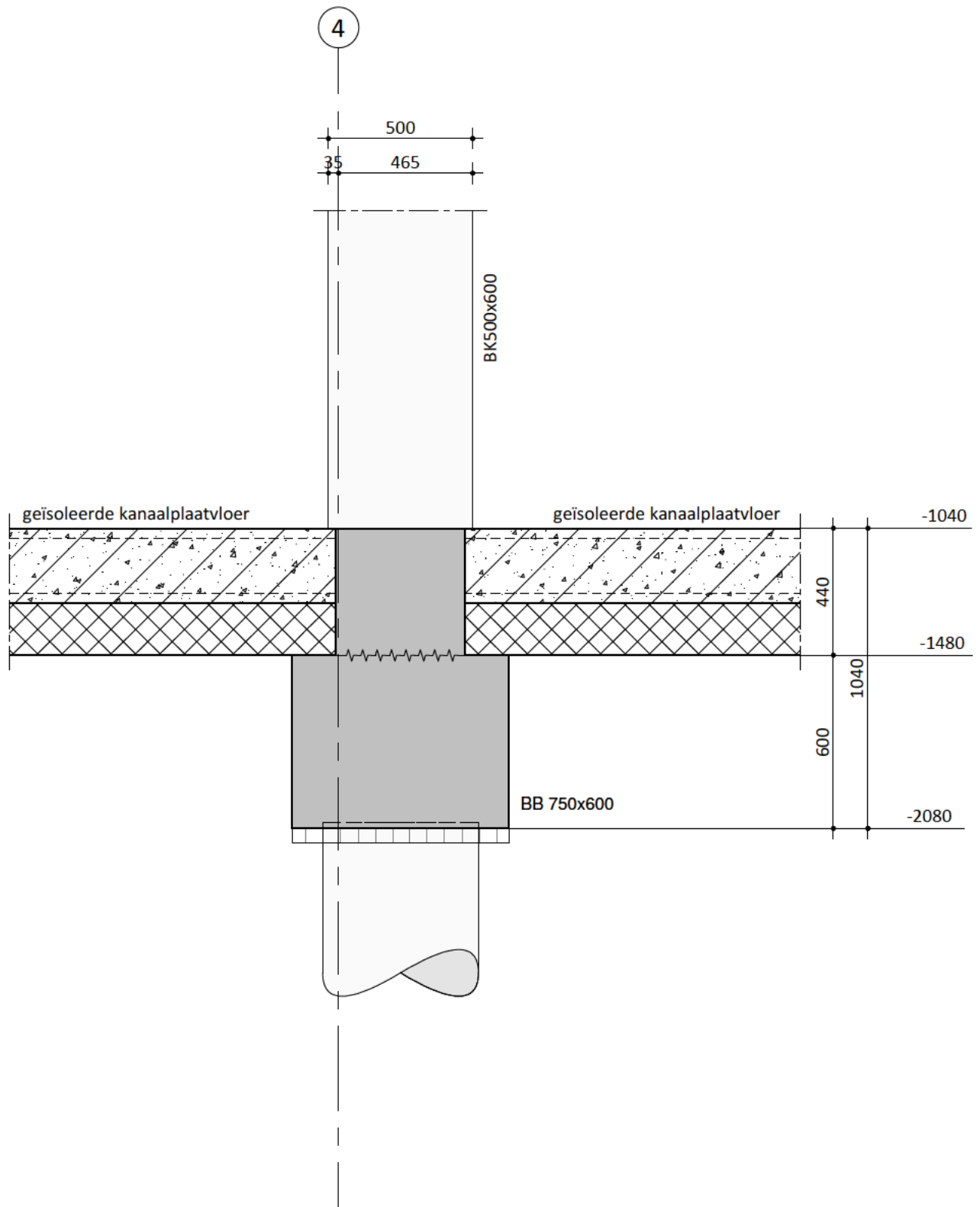

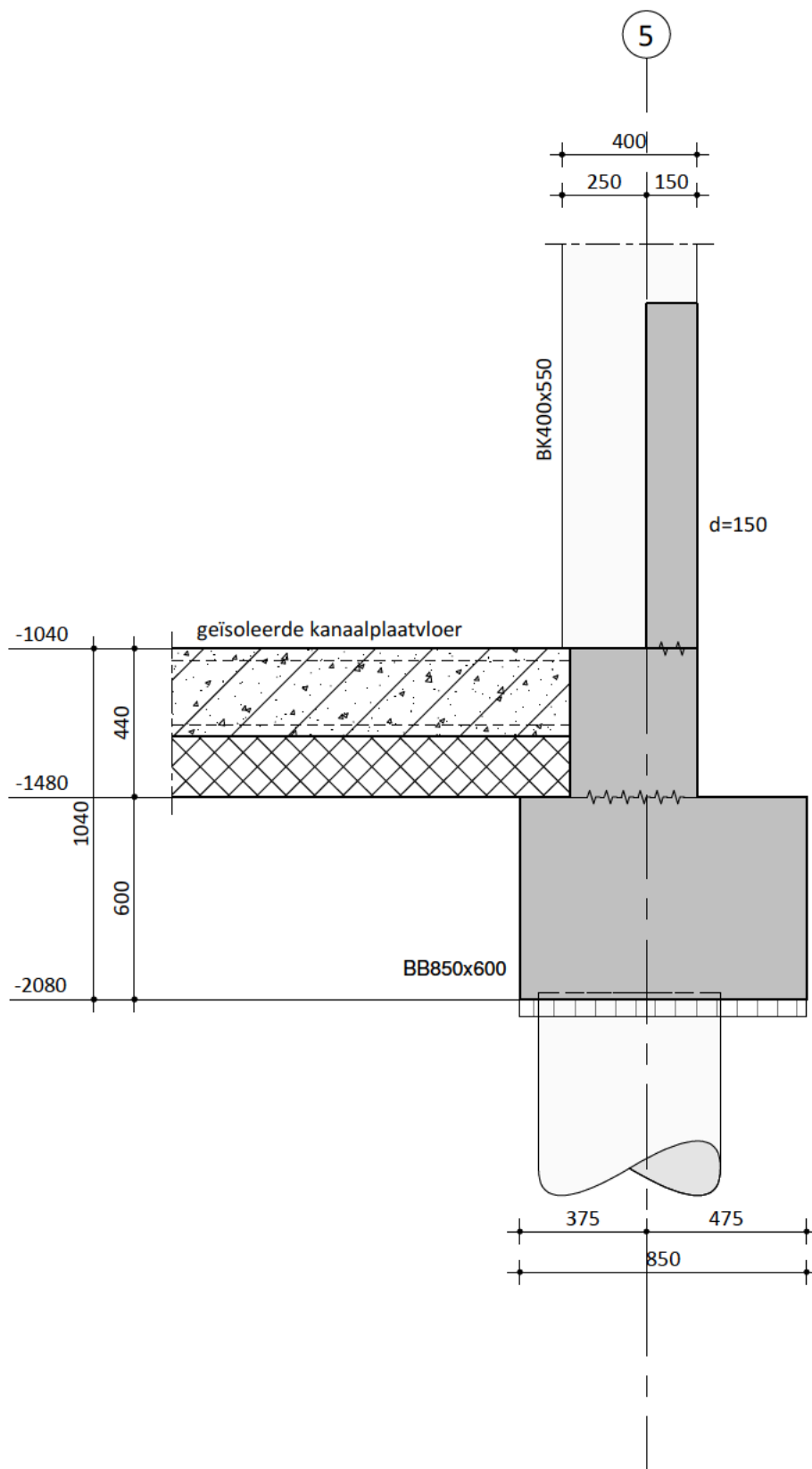

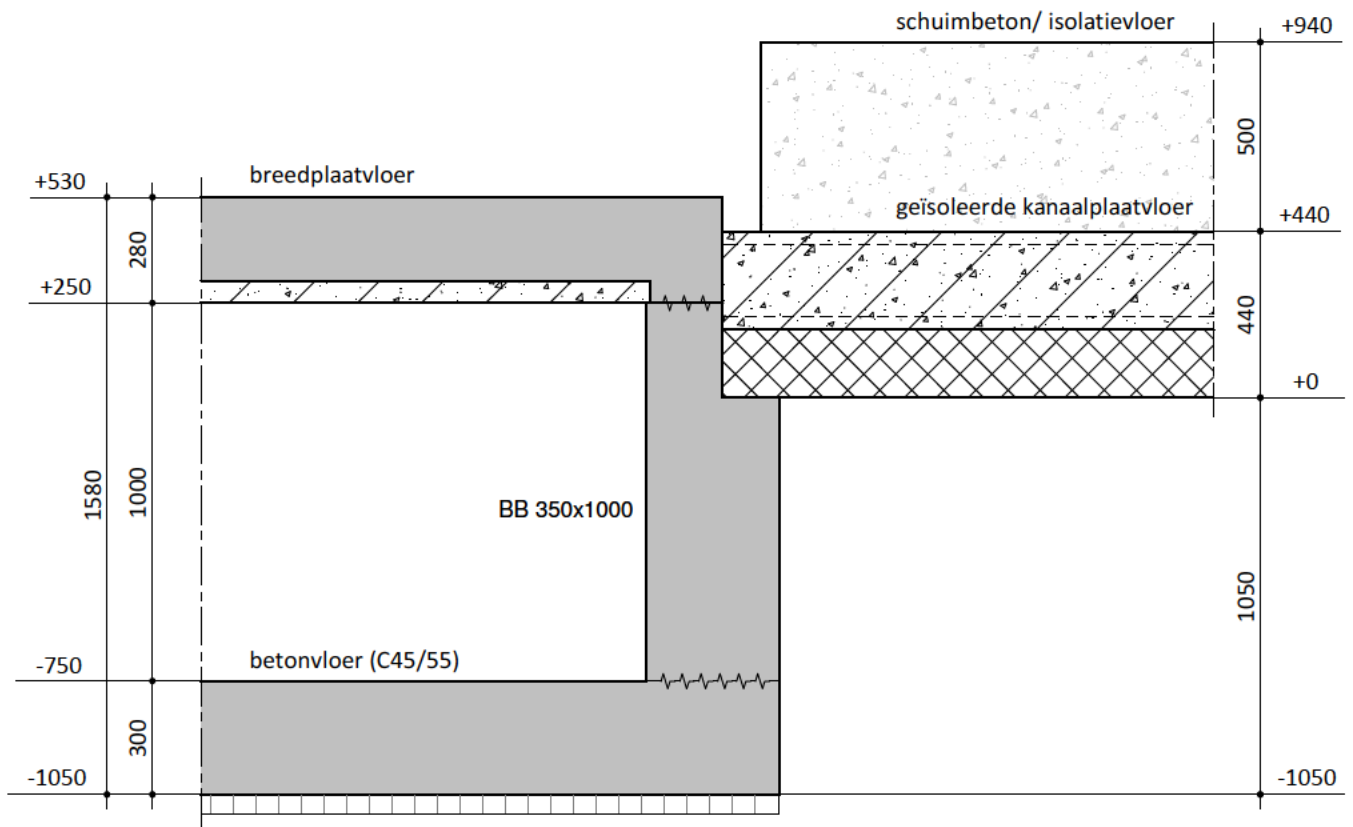

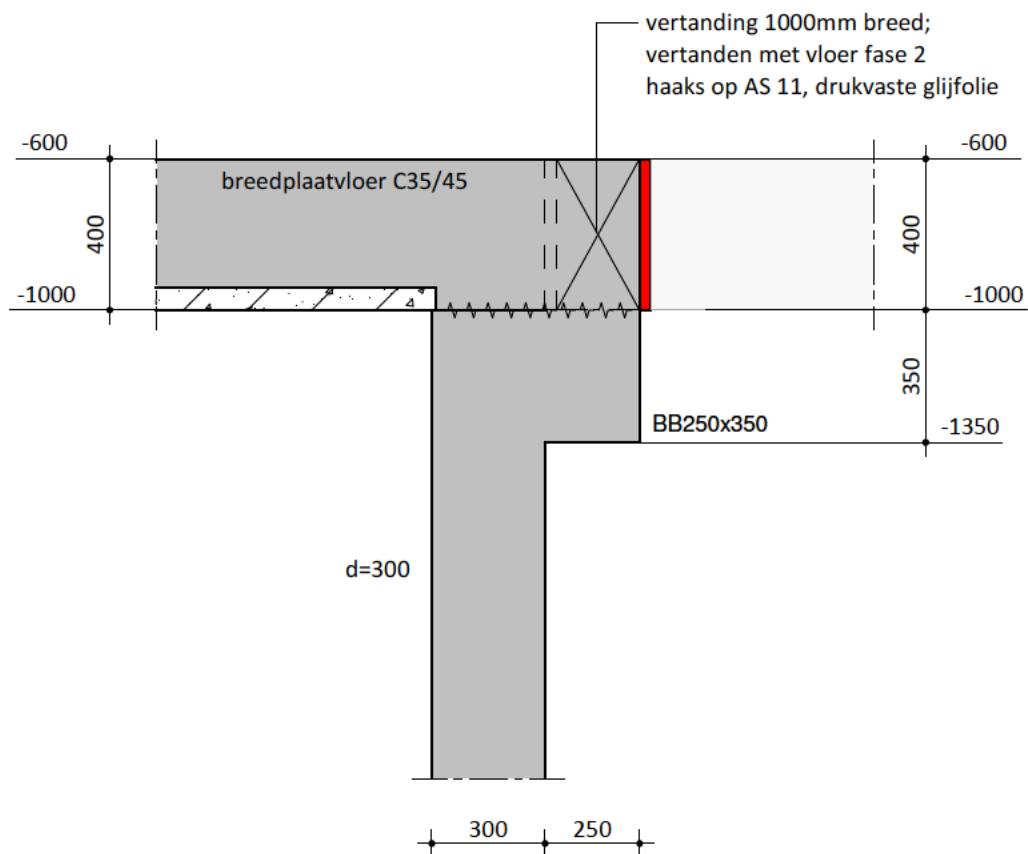

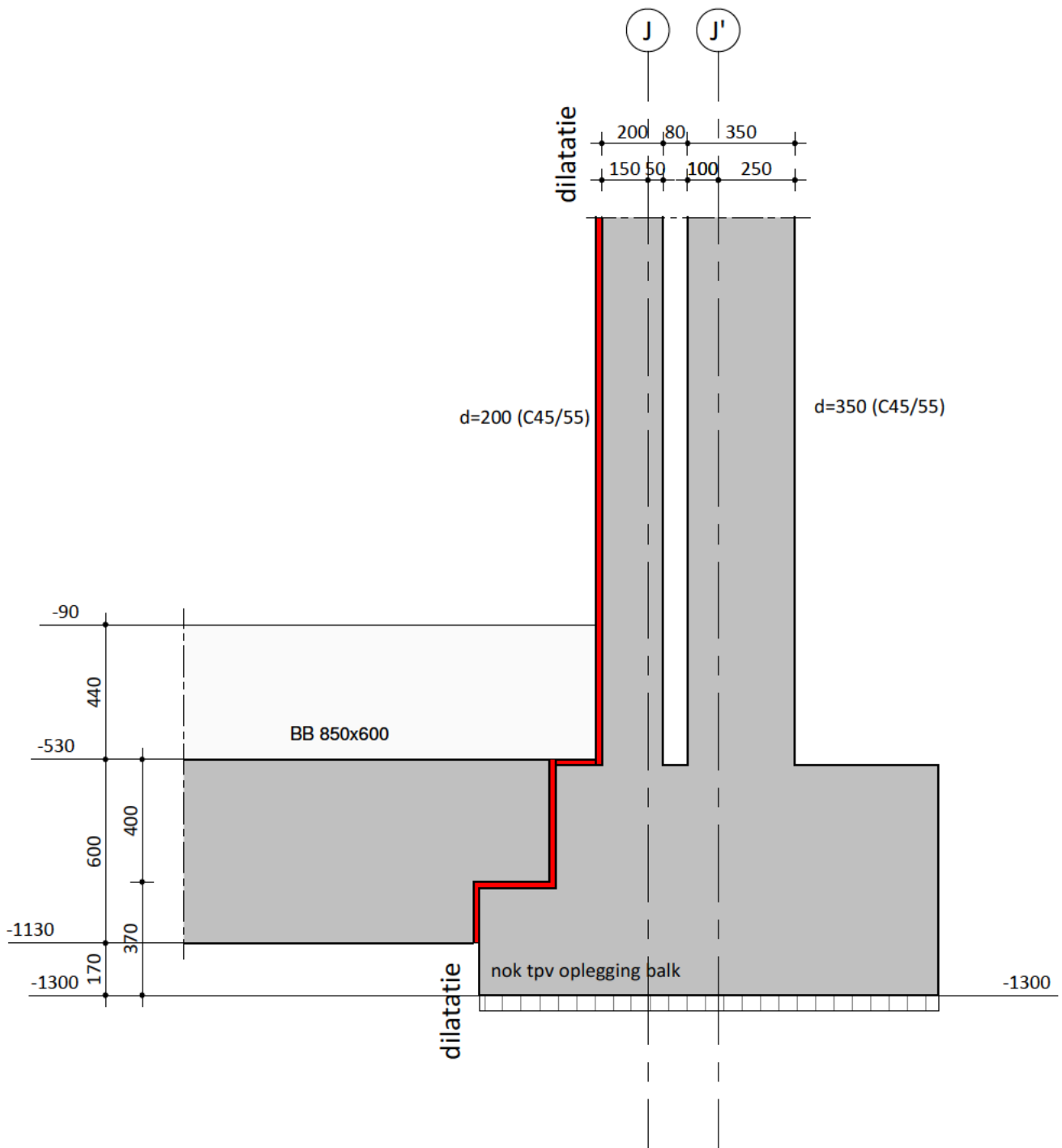

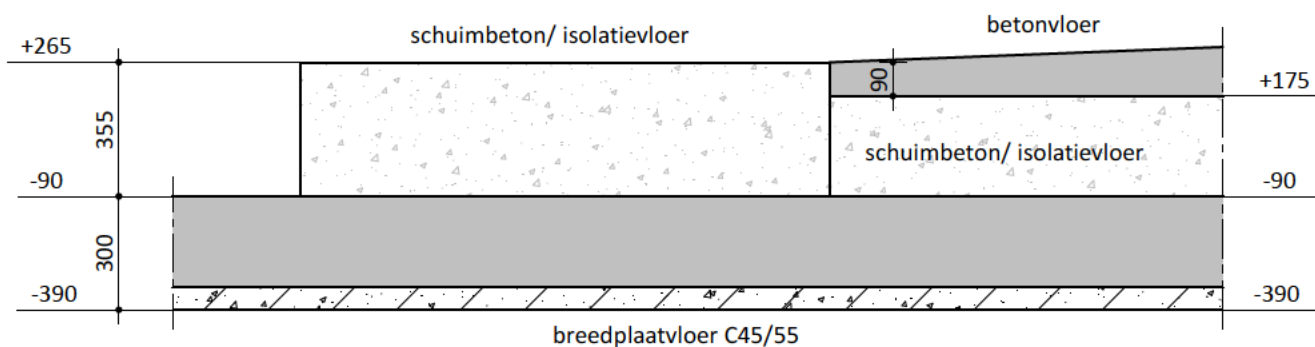



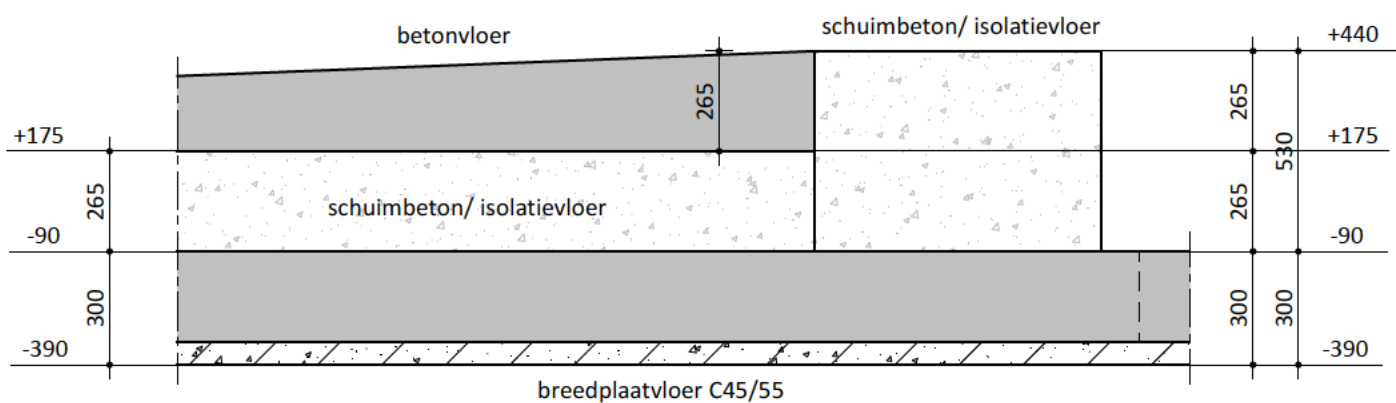

 <p>Aveco de Bondt onderzoekt ontwerpt adviseert</p>	Project : Marktkwartier West te Amsterdam			
	Schaal : 1 : 20	Datum :	Onderdeel : detail 0.87	
	Postbus 64, 7451 CH Holten T +31(0)548 85 33 33 E info@avecodebondt.nl I www.avecodebondt.nl	1.0	16-06-2023	Formaat : A4
		2.0	15-12-2023	Projectnummer: 214570
			Status : Definitief Tekeningnummer: D-0.87	



 <p>onderzoekt ontwerpt adviseert</p>	Project : Marktkwartier West te Amsterdam			
	Schaal : 1 : 20	Datum :	Onderdeel : detail 0.88	
	Postbus 64, 7451 CH Holten T +31(0)548 85 33 33 E info@avecodebondt.nl I www.avecodebondt.nl	1.0	16-06-2023	Formaat : A4
		2.0	15-12-2023	Projectnummer: 214570
			Status : Definitief Tekeningnummer: D-0.88	

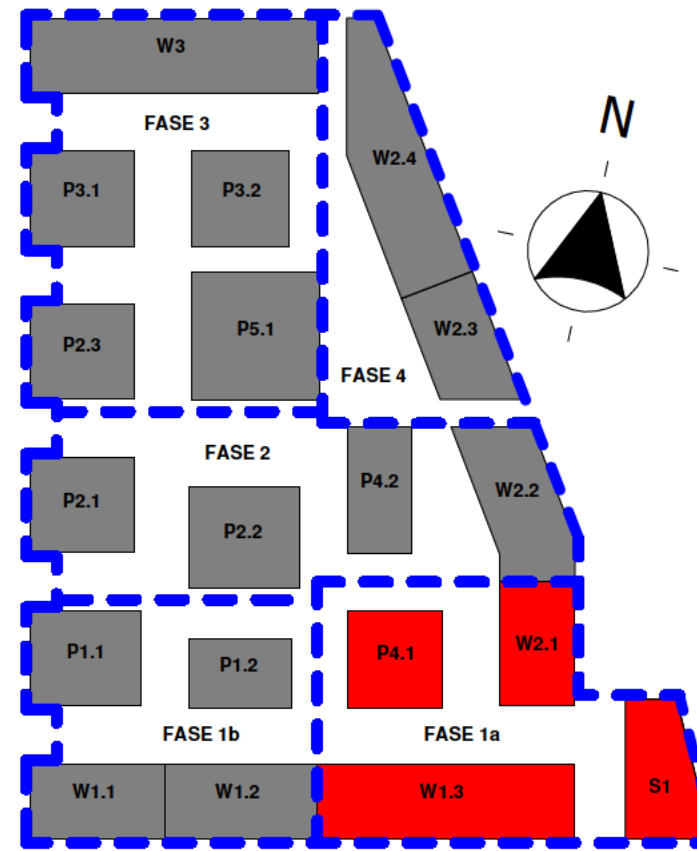

keyplan fase 1a

1 : 2000

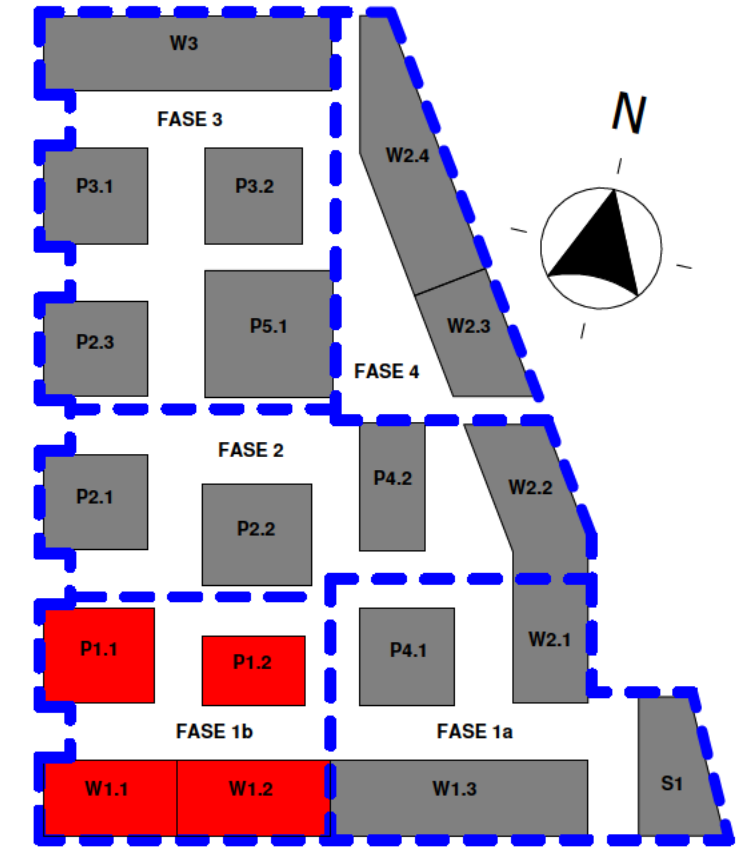

keyplan fase 1b

1 : 2000

Deze tekening is gebaseerd op:
 Model Aveco de Bondt: MKW_K_CON_ADB_R21214570
 Constructieve uitgangspunten Aveco de Bondt: 214570_AdB_RAP_K1a -0001
 Onderlegger derden: MKW_K_BWK_HFB_R21

6.0	15-12-2023	toevoeging; wijzigingen kelder ivm aanpassing naar openbaar
5.0	16-06-2023	eerste uitgave; def.
4.0	14-04-2023	toevoeging; fase 1b
3.0	15-03-2023	toevoeging; wijziging palen & diverse aanvullingen
2.0	06-01-2023	eerste uitgave; def.
1.0	21-07-2022	eerste uitgave
	Datum:	Omschrijving:

Project : Marktkwartier West te Amsterdam
 Onderdeel : Details onderbouw keldervloer
 Architect : HFB
 Aannemer : Kondor Wessels Amsterdam
 Opdrachtgever : Marktkwartier CV

Postbus 64, 7451 CH Holten
 T +31 88 004 82 12
 E info@avecodebondt.nl
 I www.avecodebondt.nl

Aveco de Bondt
 onderzoekt ontwerpt adviseert

Projectleider: ing. R.M. Voet	Fase: Definitief ontwerp	Status: Definitief	Formaat: A3
Constructeur: ir. J.M.G. Huijbregts RC			
Modelleur: H.B. Heijdemann	Schaal: Projectnummer: 214570	Tekeningsnummer: MKW_CON_K_1ab_DO-501	
Controlerend modelleur: B.H. Peters			

Tekeningenlijst details onderbouw kelder

Tekeningnr.	Status	Omschrijving	Datum	Rev	Wijz.
D--1.01	Definitief	Detail -1.01	21.07-2022	6.0	15-12-2023
D--1.02	Definitief	Detail -1.02	21.07-2022	6.0	15-12-2023
D--1.03	Definitief	Detail -1.03	21.07-2022	5.0	15-12-2023
D--1.04	Definitief	Detail -1.04	21.07-2022	5.0	15-12-2023
D--1.05	Definitief	Detail -1.05	21.07-2022	5.0	15-12-2023
D--1.06	Definitief	Detail -1.06	21.07-2022	5.0	15-12-2023
D--1.07	Definitief	Detail -1.07	21.07-2022	5.0	15-12-2023
D--1.08	Definitief	Detail -1.08	21.07-2022	5.0	15-12-2023
D--1.09	Definitief	Detail -1.09	21.07-2022	5.0	15-12-2023
D--1.10	Definitief	Detail -1.10	21.07-2022	5.0	15-12-2023
D--1.11	Definitief	Detail -1.11	14-04-2023	3.0	15-12-2023
D--1.12	Definitief	Detail -1.12	14-04-2023	3.0	15-12-2023
D--1.13	Definitief	Detail -1.13	14-04-2023	3.0	15-12-2023



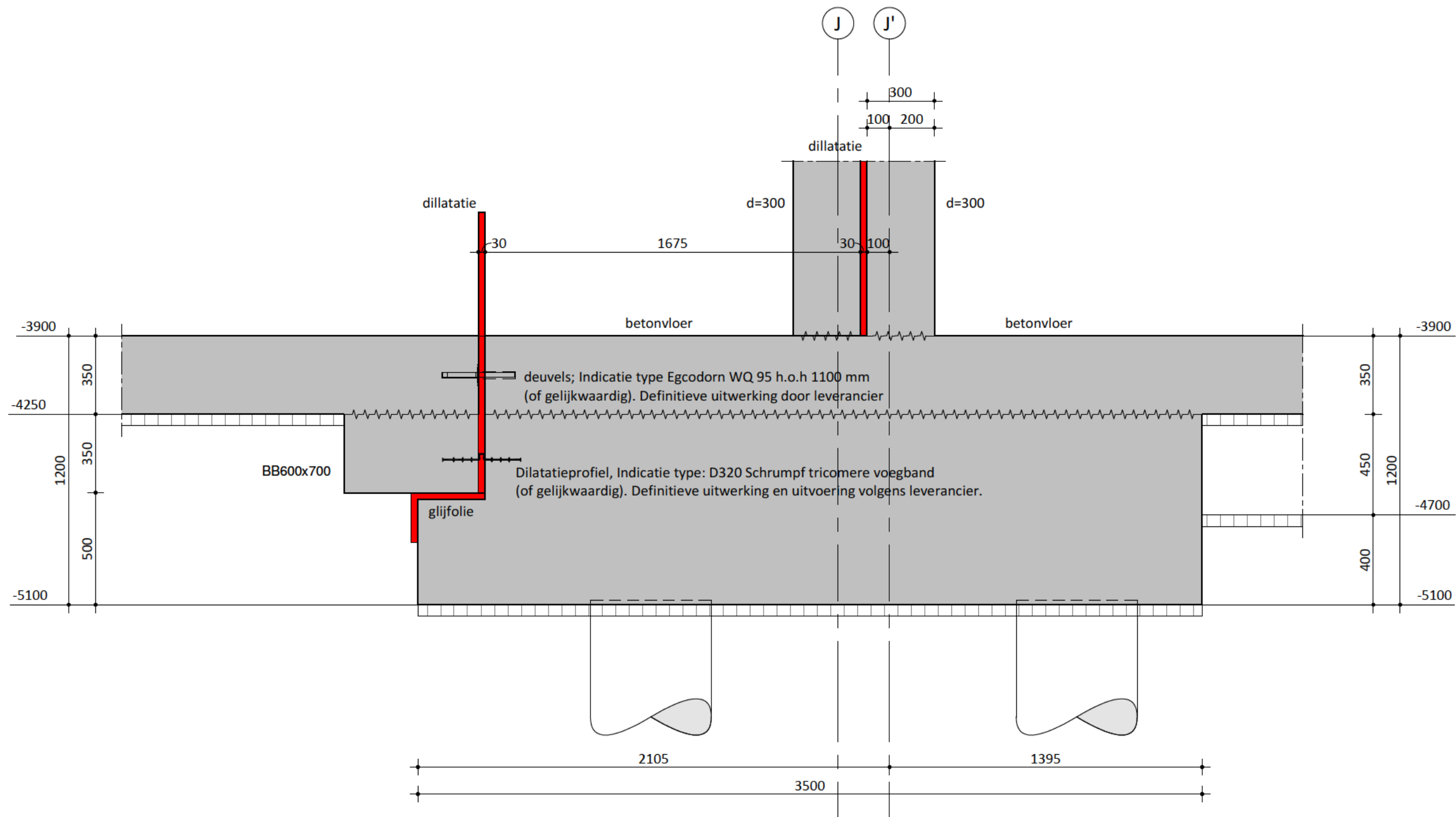

Project : Marktkwartier West te Amsterdam

Schaal :	Datum :	Onderdeel : overzicht details onderbouw kelder	Status : Definitief
Postbus 64, 7451 CH Holten T +31(0)548 85 33 33 E info@avecodebondt.nl I www.avecodebondt.nl	1.0 21.07-2022 5.0 16-06-2023 6.0 15-12-2023	Formaat : A3 Projectnummer: 214570	Tekeningnummer: D-01-D3-02i

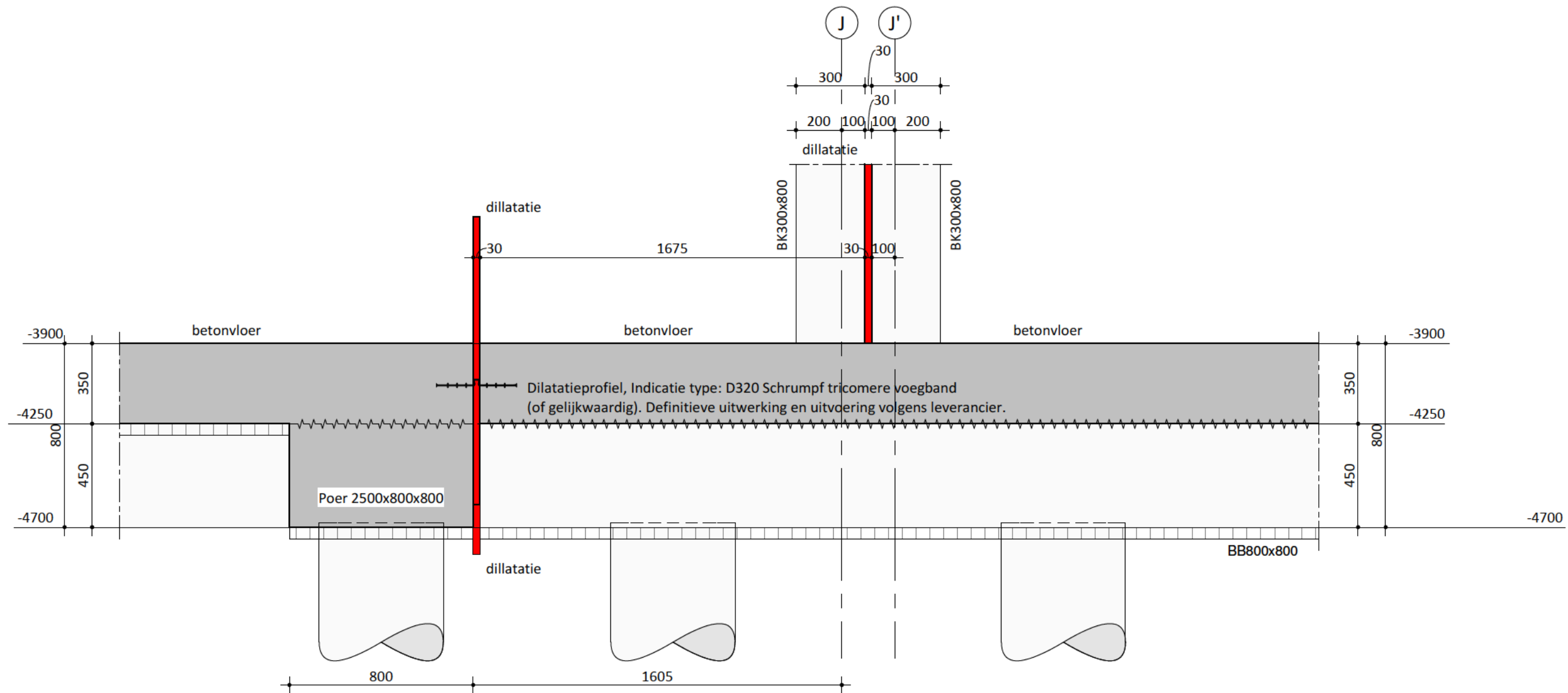

 <p>onderzoekt ontwerpt adviseert</p>	Project : Marktkwartier West te Amsterdam			
	Schaal : 1 : 20	Datum :	Onderdeel : Detail -1.01	
	Postbus 64, 7451 CH Holten T +31(0)548 85 33 33 E info@avecodebondt.nl I www.avecodebondt.nl	1.0	21.07-2022	Formaat : A3
		5.0	16-06-2023	Projectnummer: 214570
6.0	15-12-2023	Status : Definitief	Tekeningnummer: D--1.01	



 <p>onderzoekt ontwerpt adviseert</p>	Project : Marktkwartier West te Amsterdam			
	Schaal : 1 : 20	Datum :	Onderdeel : Detail -1.02	
	Postbus 64, 7451 CH Holten T +31(0)548 85 33 33 E info@avocodebondt.nl I www.avocodebondt.nl	1.0 21.07-2022	Formaat : A3	Status : Definitief
		5.0 16-06-2023	Projectnummer: 214570	Tekeningnummer: D--1.02
	6.0 15-12-2023			

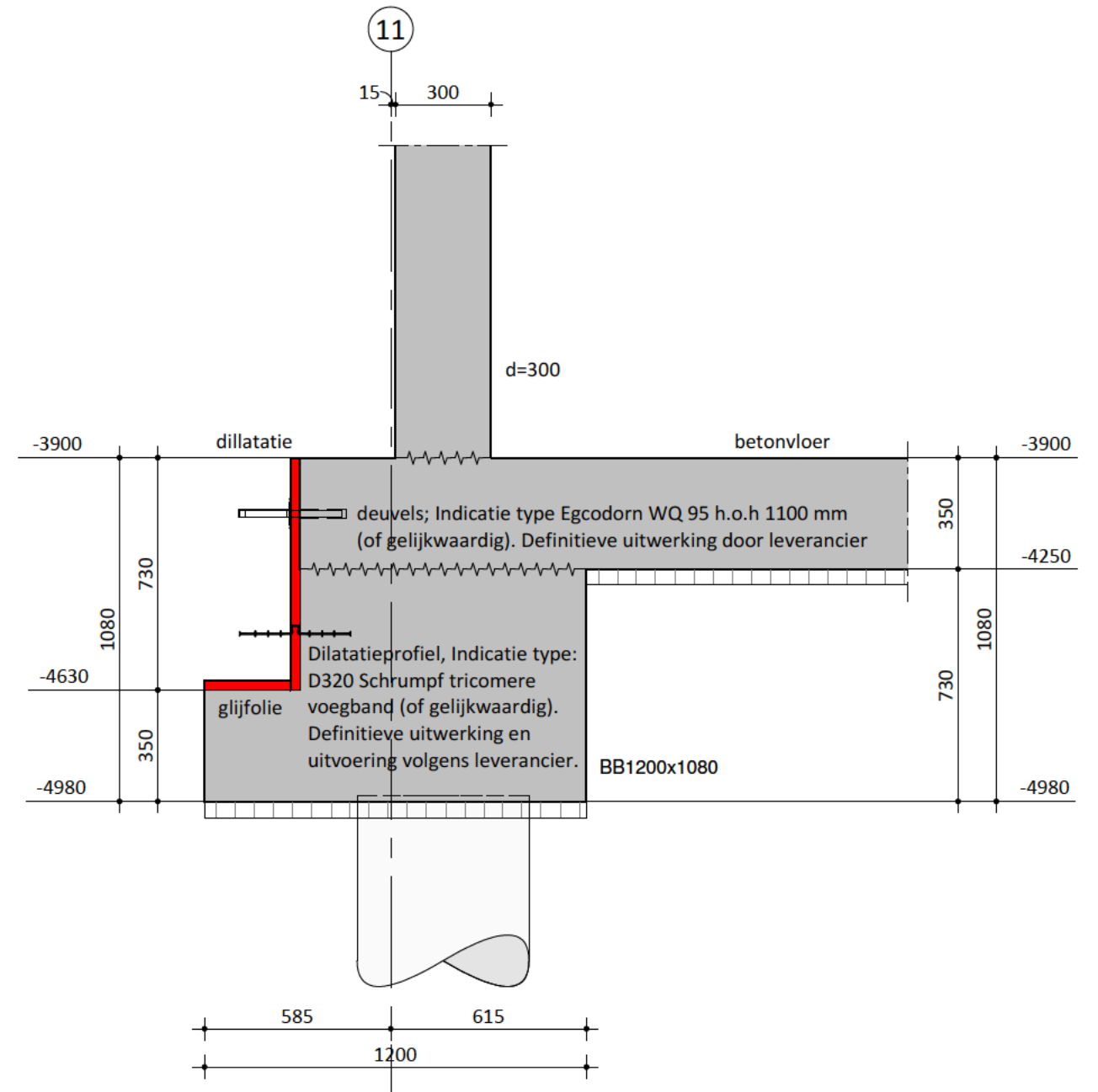

Project : Marktkwartier West te Amsterdam			
Schaal : 1 : 20	Datum :	Onderdeel : Detail -1.03	
Postbus 64, 7451 CH Holten T +31(0)548 85 33 33 E info@avecodebondt.nl I www.avecodebondt.nl	1.0	21.07-2022	Formaat : A3
	4.0	16-06-2023	Projectnummer:
	5.0	15-12-2023	214570
			Status : Definitief
			Tekeningnummer: D--1.03

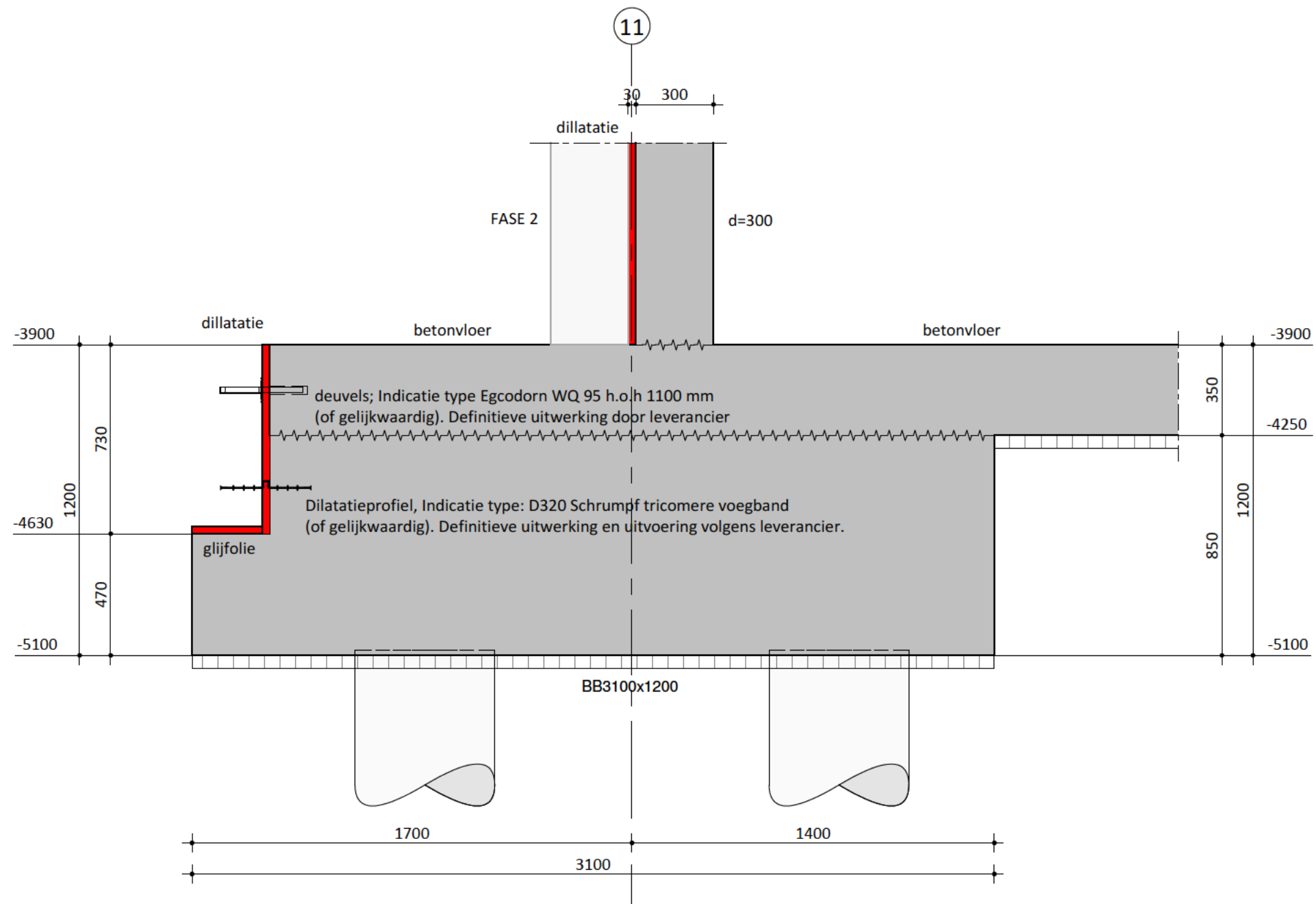

Project : Marktkwartier West te Amsterdam			
Schaal : 1 : 20	Datum :	Onderdeel : Detail -1.04	
Postbus 64, 7451 CH Holten T +31(0)548 85 33 33 E info@avecodebondt.nl I www.avecodebondt.nl	1.0	21.07-2022	Formaat : A3
	4.0	16-06-2023	Projectnummer:
	5.0	15-12-2023	214570
			Tekeningnummer: D--1.04

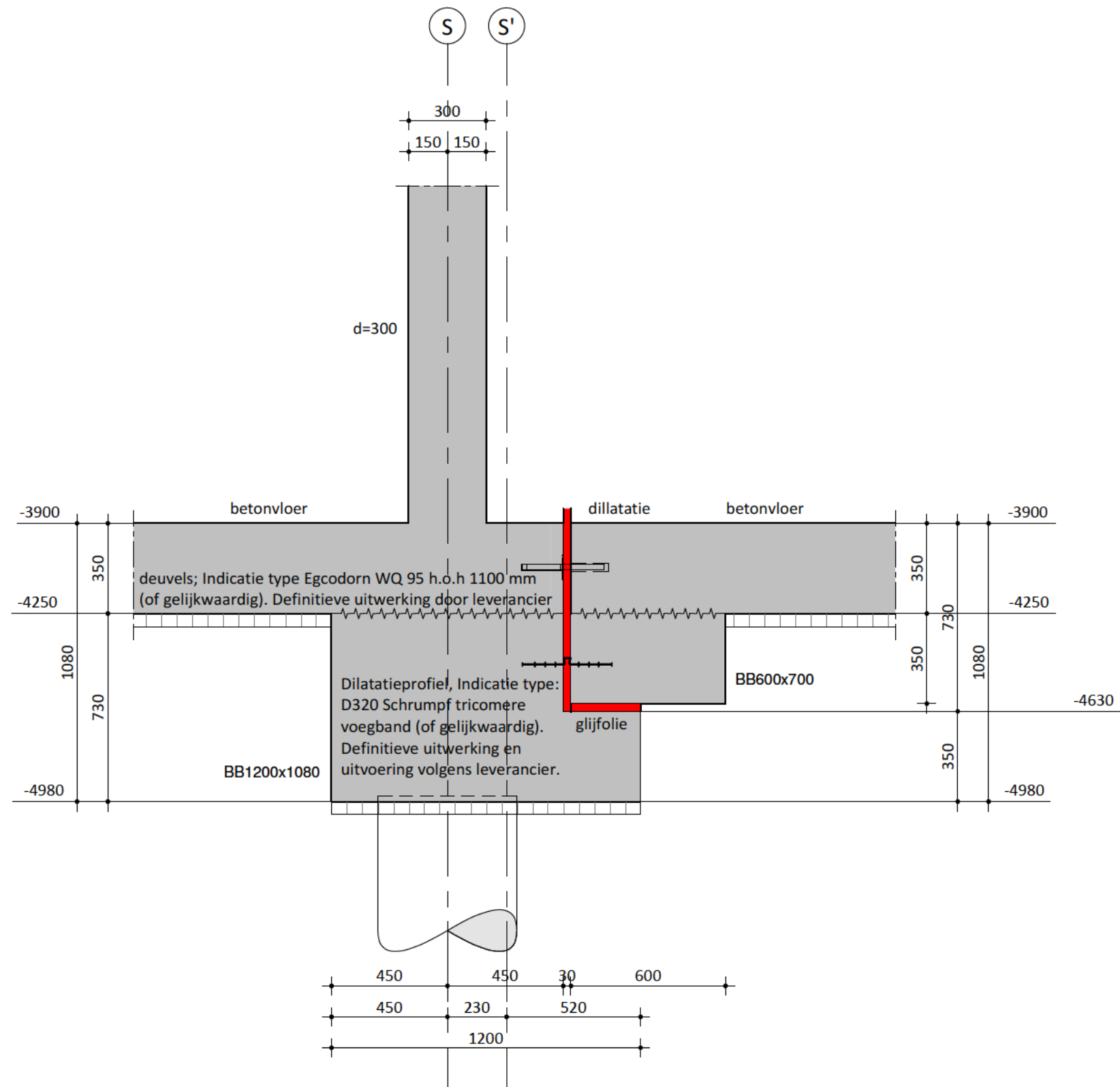

Project : Marktkwartier West te Amsterdam			
Schaal : 1 : 20	Datum :	Onderdeel : Detail -1.05	
Postbus 64, 7451 CH Holten T +31(0)548 85 33 33 E info@avecodebondt.nl I www.avecodebondt.nl	1.0	21.07-2022	Formaat : A3
	4.0	16-06-2023	Projectnummer:
	5.0	15-12-2023	214570
			Status : Definitief
			Tekeningnummer: D--1.05

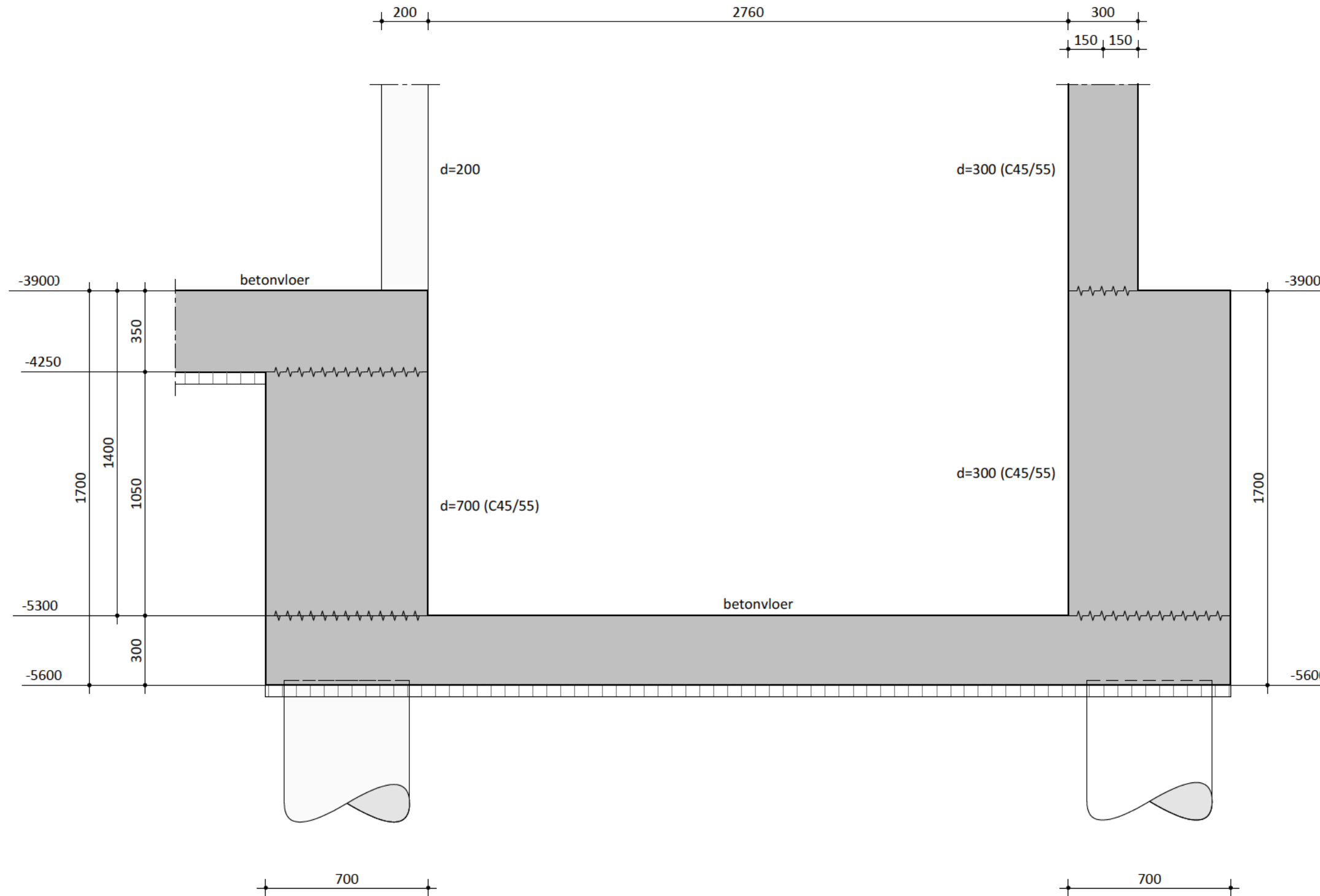

 <p>onderzoekt ontwerpt adviseert</p>	Project : Marktkwartier West te Amsterdam				
	Schaal : 1 : 20	Datum :	Onderdeel : Detail -1.06		
	Postbus 64, 7451 CH Holten T +31(0)548 85 33 33 E info@avocodebondt.nl I www.avocodebondt.nl	1.0	21.07-2022	Formaat : A3	Status : Definitief
		4.0	16-06-2023	Projectnummer:	Tekeningnummer:
	5.0	15-12-2023	214570	D--1.06	

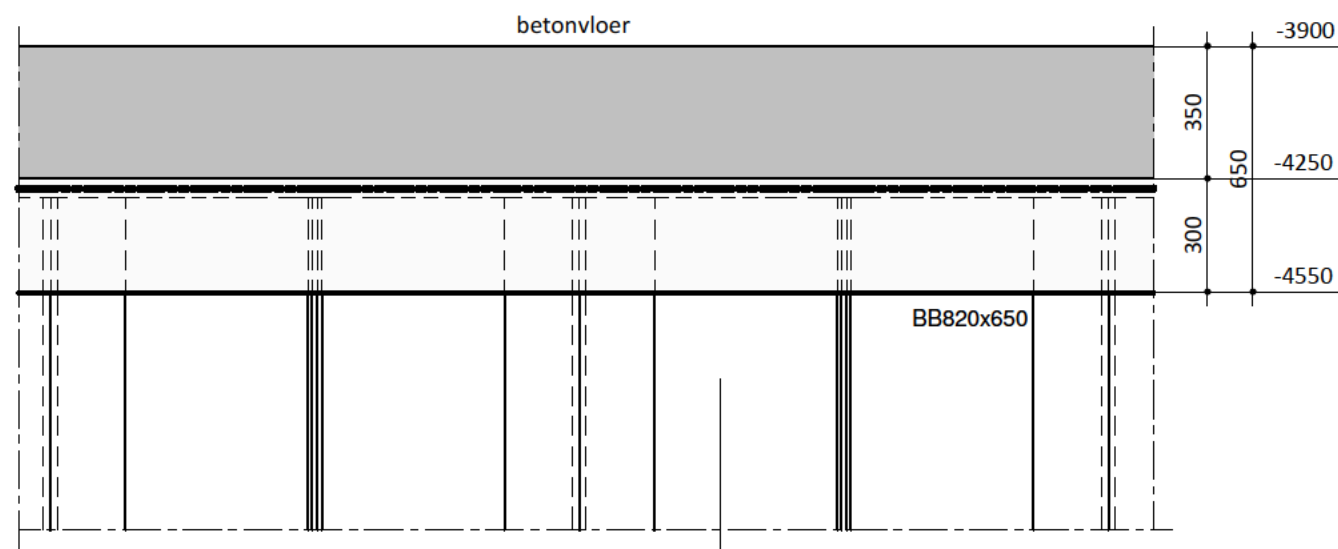

VAZ -1.07

1 : 20

Waterkering niet dragend uitvoeren
d.m.v. schuimband op bovenzijde
waterkering moet +/- 25 mm ingedrukt kunnen
worden zonder dat het waterscherm gat dragen
e.e.a. in overleg met aannemer

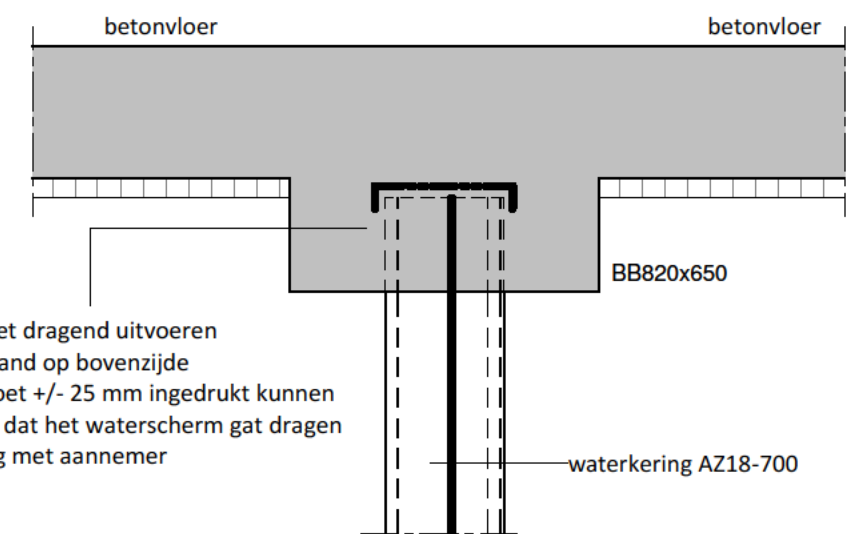

-1.07

1 : 20

Waterkering niet dragend uitvoeren
d.m.v. schuimband op bovenzijde
waterkering moet +/- 25 mm ingedrukt kunnen
worden zonder dat het waterscherm gat dragen
e.e.a. in overleg met aannemer

waterkering AZ18-700

	Project : Marktkwartier West te Amsterdam				
	Schaal : 1 : 20	Datum :	Onderdeel : Detail -1.07		
	Postbus 64, 7451 CH Holten T +31(0)548 85 33 33 E info@avecodebondt.nl I www.avecodebondt.nl	1.0	21.07-2022	Formaat : A3	Status : Definitief
		4.0	16-06-2023	Projectnummer:	Tekeningnummer:
		5.0	15-12-2023	214570	D--1.07

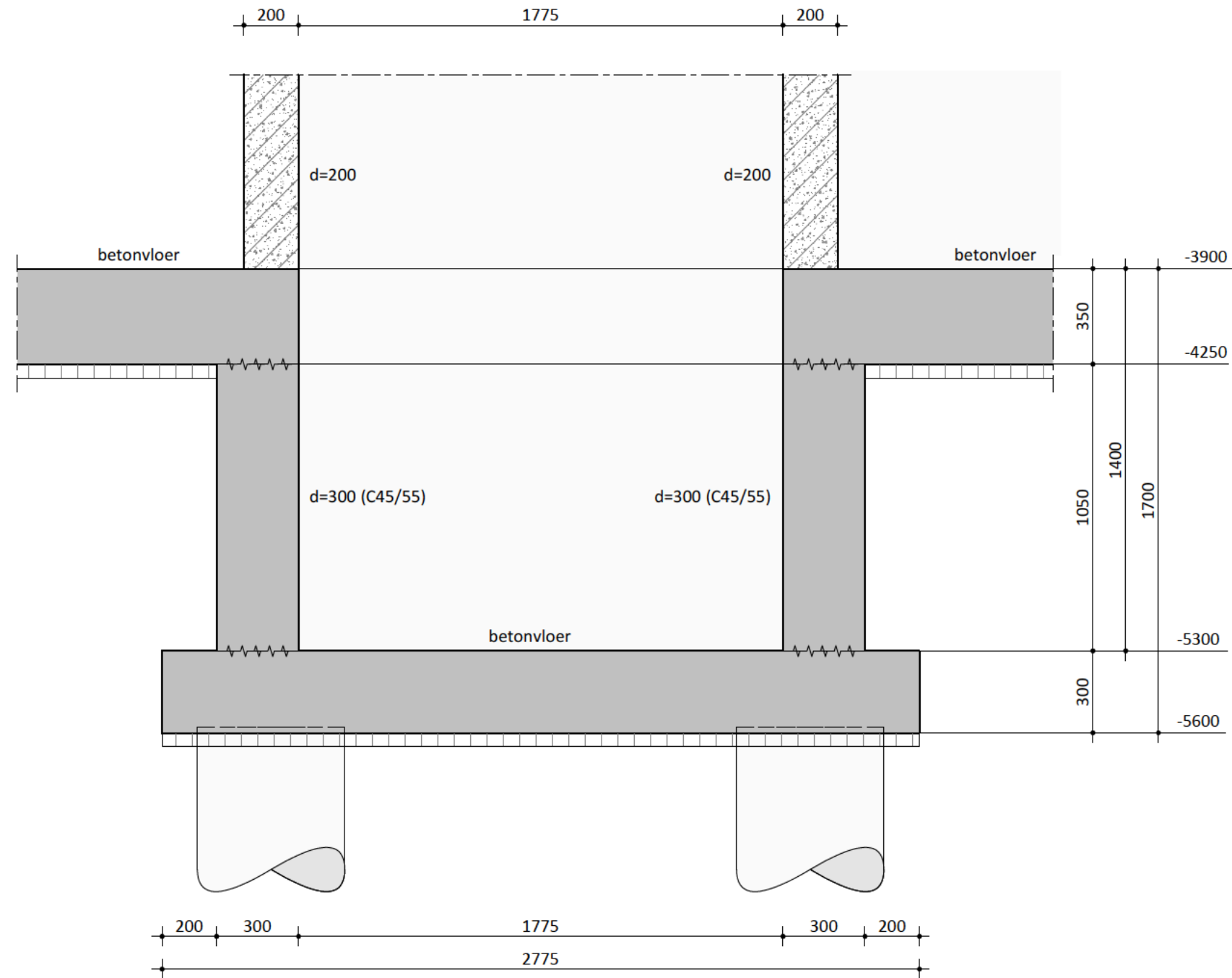

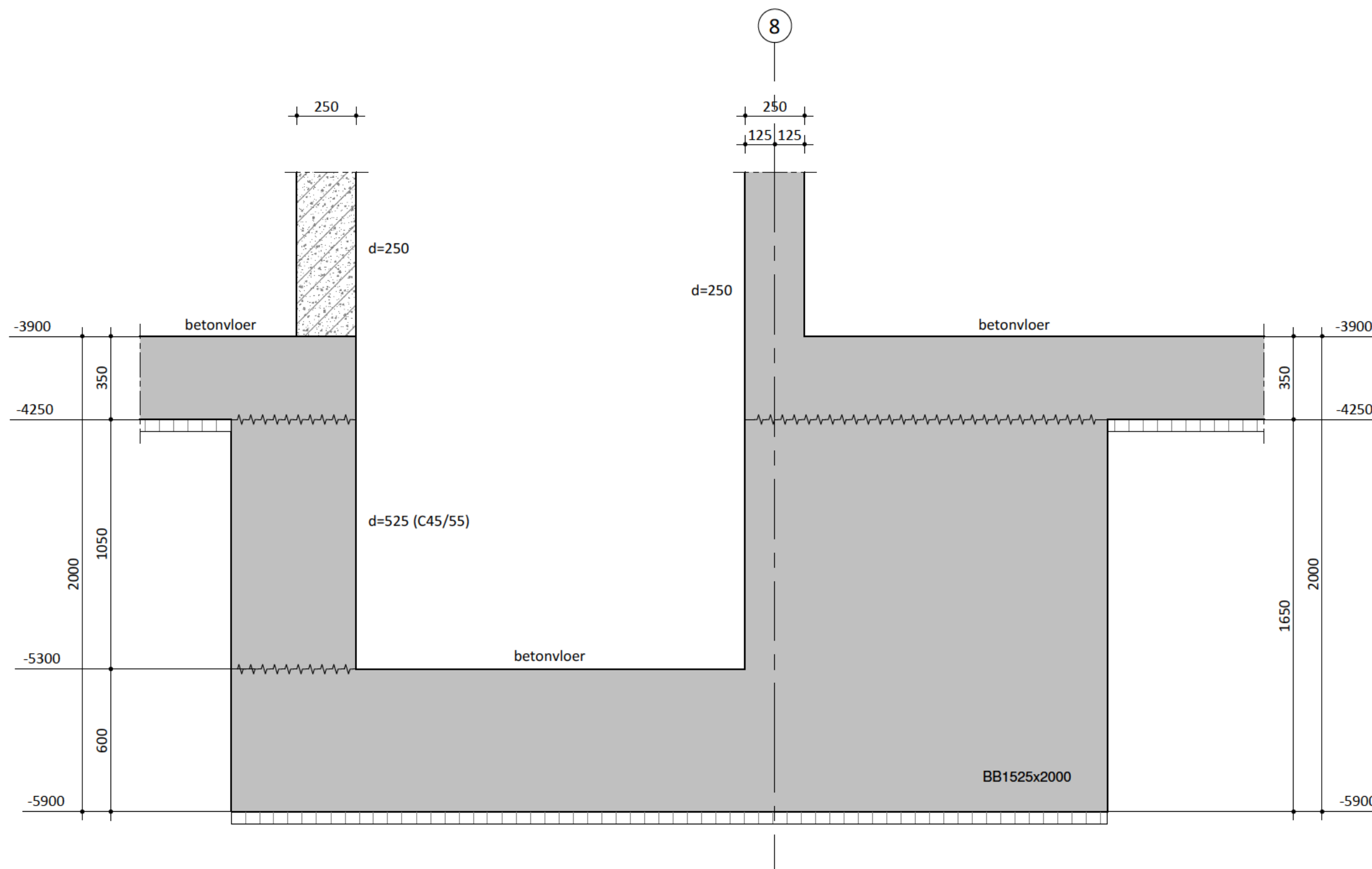

Project : Marktkwartier West te Amsterdam			
Schaal : 1 : 20	Datum :	Onderdeel : Detail -1.08	
Postbus 64, 7451 CH Holten T +31(0)548 85 33 33 E info@avecodebondt.nl I www.avecodebondt.nl	1.0	21.07-2022	Formaat : A3
	4.0	16-06-2023	Projectnummer:
	5.0	15-12-2023	214570
			Tekeningnummer: D--1.08

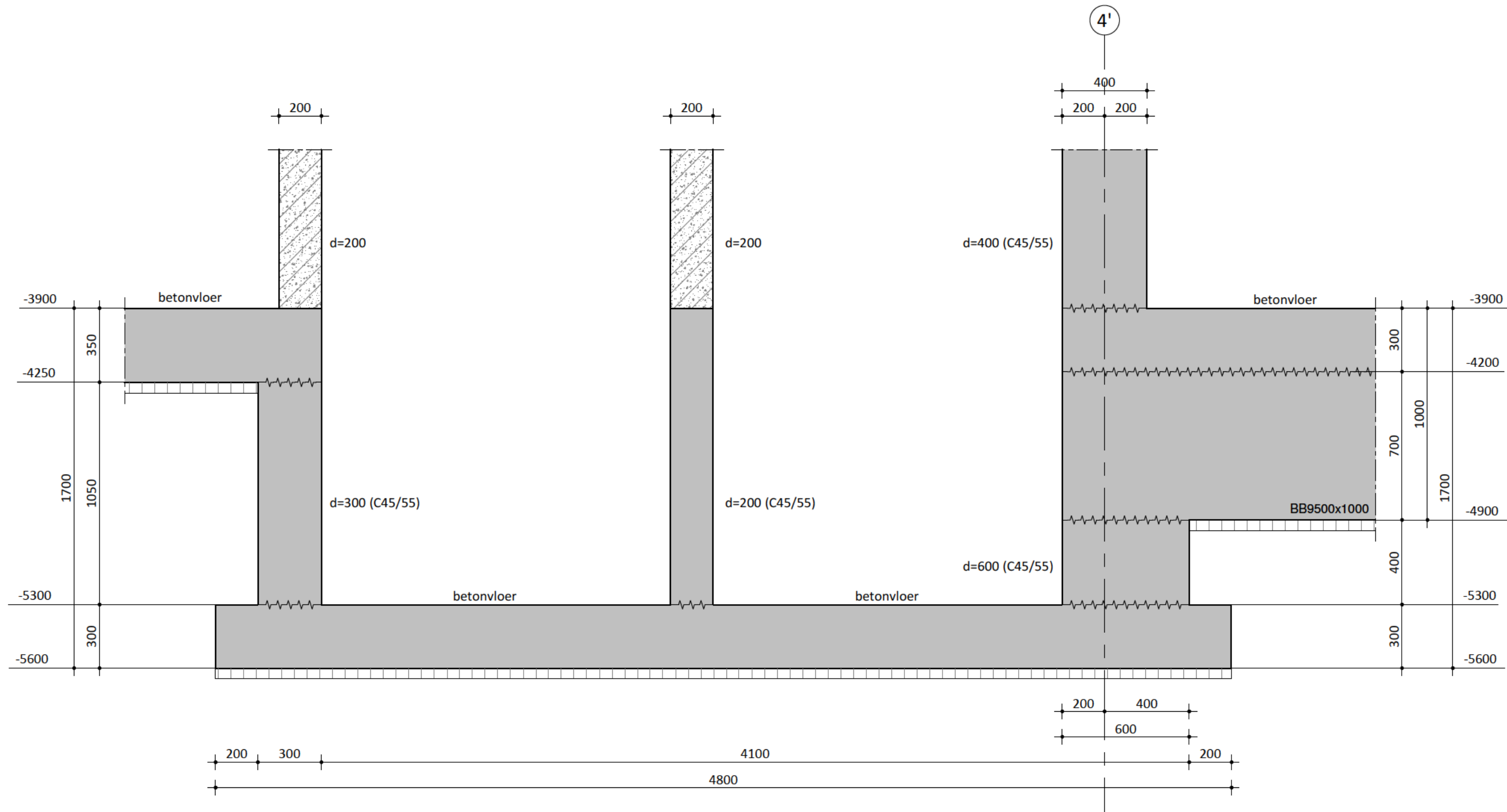

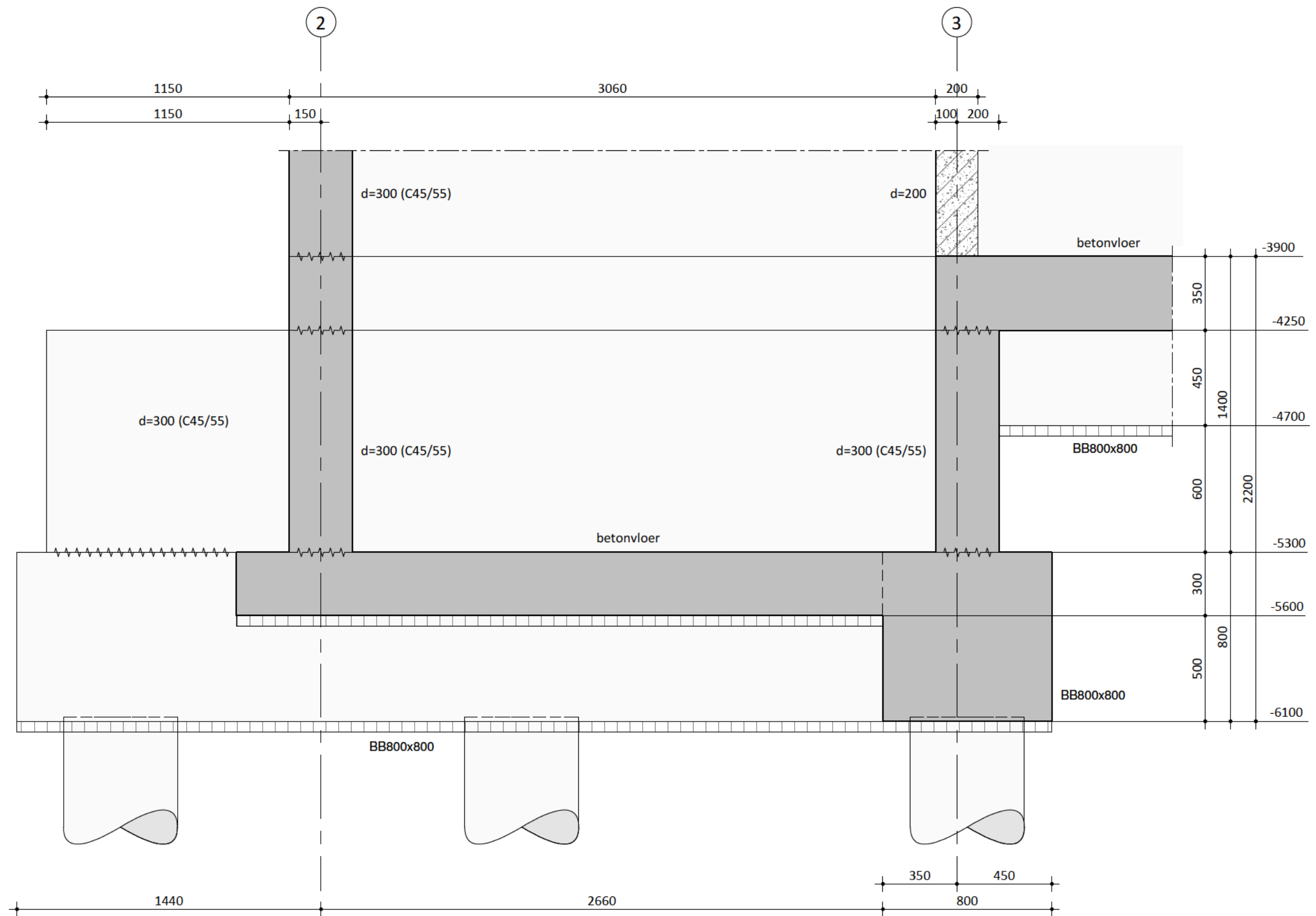

Project : Marktkwartier West te Amsterdam			
Schaal : 1 : 20	Datum :	Onderdeel : Detail -1.10	
Postbus 64, 7451 CH Holten T +31(0)548 85 33 33 E info@avecodebondt.nl I www.avecodebondt.nl	1.0	21.07-2022	Formaat : A3
	4.0	16-06-2023	Projectnummer:
	5.0	15-12-2023	214570
			Status : Definitief
			Tekeningnummer: D--1.10



 <p>onderzoekt ontwerpt adviseert</p>	Project : Marktkwartier West te Amsterdam			
	Schaal : 1 : 20	Datum :	Onderdeel : Detail -1.11	
	Postbus 64, 7451 CH Holten T +31(0)548 85 33 33 E info@avecodebondt.nl I www.avecodebondt.nl	1.0 14-04-2023	Formaat : A3	Status : Definitief
		2.0 16-06-2023	Projectnummer: 214570	Tekeningnummer: D--1.11
	3.0 15-12-2023			

9

