

# LUNA2000-200KWH-2H1 Smart String ESS



More Energy



Simple O&M



Safe & Reliable

## Energy Storage System Parameters

Battery Configuration	12S1P
Maximum battery capacity of the energy storage system	193.5 kWh
Rated Power	100 kW
Dimensions (W x H x D), including DC/DC and PCS	2570mm×2135mm×1200mm
Dimensions (W x H x D)	1810mm×2135mm×1200mm
Weight (including the battery module)	≤2950kg
Weight (without the battery module)	≤1070kg
Operating temperature range	-30 °C ~ 55 °C
Storage temperature range	-40 °C ~ 60 °C
Operating humidity range	0 ~ 100% (non-condensing)
Maximum operating altitude	4,000 m
Installation Environment Requirement	Outdoor installation
Battery temperature control mode	Industrial-grade air conditioner
Fire suppression of energy storage system	YES
Auxiliary Power Supply	220Vac, ≤4.2kVA
Communication port	Ethernet / SFP
Communication protocol	Modbus TCP
Protection degree	IP55
EMC Protection Rating	ClassA
DC Lightning Protection	Type II

## Standards

Environment	RoHS6
Certification Standards	GBT 36276-2018; IEC62619; UL9540A;UN38.3

# Battery Pack & Smart Rack Controller

## Smart String ESS



Battery Pack	
General	
Cell Material	LFP
Rated Voltage	57.6 V
Nominal Capacity	16.13kWh
Supported Charge & Discharge Rate	≤ 0.5 C
Weight	≤ 140 kg
Dimensions (W x H x D)	442 x 308 x 660 mm



Smart Rack Controller	
Efficiency	
Max. Efficiency	≥ 98.5.0%
Battery Side	
Rated Voltage	691.2@280Ah
Operating Voltage Range	40 V ~ 1,050 V
Min. Start Voltage	350 V
Bus Side	
Max. DC Voltage	1,100 V
Rated Voltage	665 V
Rated Current	76.3 A
General	
Dimensions (W x H x D)	600 x 270 x 820 mm
Weight	≤ 90 kg
Cooling Method	Smart Air Cooling
Protection Degree	IP66

# LUNA2000-100KTL-M1 Smart PCS



Surge Arresters for  
DC & AC



Modular Design



IP66 Protection



Ethernet  
Communication



Smart Grid  
Algorithm

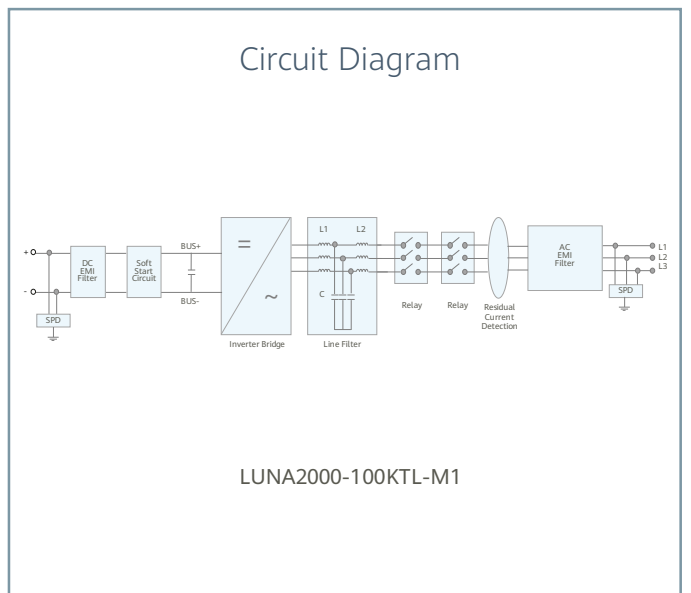
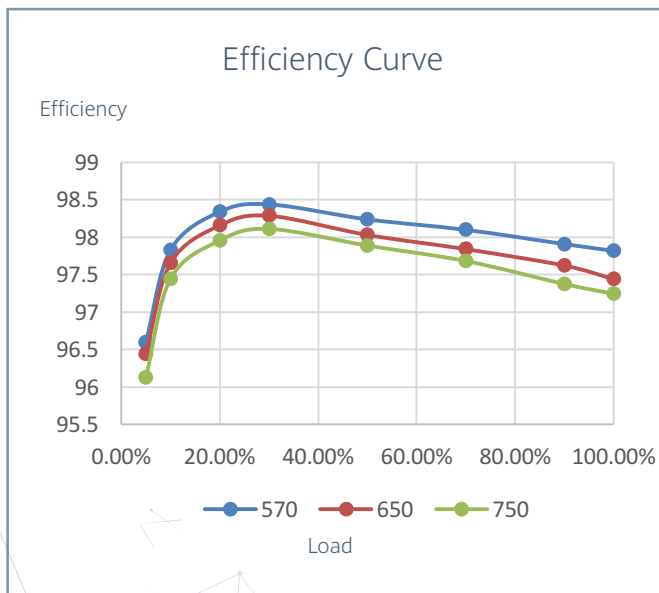

# LUNA2000-100KTL-M1

## Technical Specifications



Efficiency	
Max. Efficiency	98.4%
DC Side	
Rated DC Voltage	645 V
Max. DC Voltage	1,100 V
Operating DC Voltage Range	570 V ~ 1100 V
Max. DC Current	215.8 A
Max. Number of Inputs	1
AC Side	
Rated AC Active Power	100,000 W @40°C
Rated AC Voltage	380 Vac / 400 Vac / 440 Vac
Rated AC Grid Frequency	50 Hz / 60 Hz
Max. AC Current	173.2 A
Adjustable Power Factor Range	-1 ... +1
Max. Total Harmonic Distortion	< 3%
Protection	
Anti-islanding Protection	Yes
AC Overcurrent Protection	Yes
DC Reverse-polarity Protection	Yes
Insulation Resistance Detection	Yes
Residual Current Protection	Yes
DC Surge Protection	Type II
AC Surge Protection	Type II
Communication	
Display	LED Indicators, WLAN + APP
Networking Mode	Ethernet, CAN
General	
Dimensions (W x H x D)	875 x 820 x 365 mm
Weight	< 95 kg
Operating Temperature Range	-25°C ~ 60°C ( Derating above 40°C )
Cooling Method	Smart Air Cooling
Max. Operating Altitude without Derating	4,000 m
Relative Humidity	0 ~ 100%
DC Connector	OT/DT Terminal
AC Connector	OT/DT Terminal
Protection Degree	IP66
Topology	Transformerless

